

Alarm Control Panel

VERSA PLUS LTE

Firmware Version 1.10

Satel®



USER MANUAL

EN

versa_plus_lte_u_en 09/21

SATEL sp. z o.o.
ul. Budowlanych 66 • 80-298 Gdańsk • POLAND
tel. +48 58 320 94 00
www.satel.eu

IMPORTANT

Before you start using the control panel, please read carefully this manual in order to avoid mistakes that can lead to malfunction or even damage to the equipment.

Changes, modifications or repairs not authorized by the manufacturer shall void your rights under the warranty.

The control panels should only be connected to the **analog subscriber lines**. In case of changing the analog line to the digital one, it is necessary to contact the alarm system installer.

Pay special attention if the telephone line used by the control panel is frequently busy and/or failures are reported, concerning the line and/or monitoring. Report such situations to the alarm system installer immediately.

To ensure adequate protection, the alarm security system must be in good working order, therefore SATEL recommends that it be regularly tested. The control panel is equipped with a number of self-diagnostic functions which, when properly configured by the installer, ensure control over correct functioning of the system.

The alarm security system cannot prevent burglary, assault or fire from happening, but it guarantees that in case of emergency measures will be taken to reduce the possible damage (the alarm will be signaled optically and acoustically, appropriate services will be notified, etc.), which may deter the potential burglars.

SATEL aims to continually improve the quality of its products, which may result in changes in their technical specifications and software. Current information about the changes being introduced is available on our website.

Please visit us:

<https://support.satel.eu>

Hereby, SATEL sp. z o.o. declares that the radio equipment type VERSA Plus LTE is in compliance with Directive 2014/53/EU. The full text of the EU declaration of conformity is available at the following internet address: www.satel.eu/ce

Factory default codes:

Service code: 12345

User 30 code: 1111

The following symbols may be used in this manual:



- note,



- caution.

CONTENTS

1. Introduction	3
2. Technical reliability of the alarm system	3
3. Alarm system operating costs	3
4. Glossary	4
5. Control panel compliance with EN 50131 standard requirements for Grade 2	5
6. Operating the alarm system with LCD keypad	6
6.1 Keypads description	7
6.1.1 LEDs presenting partition and system state	7
6.1.2 Display.....	8
6.1.3 Keys	9
6.1.4 Built-in proximity card reader	9
6.1.5 Sound signaling.....	9
6.2 Codes.....	11
6.2.1 Factory default codes	11
6.3 Arming.....	11
6.3.1 Arming without partition selection	11
6.3.2 Arming with proximity card VERSA-LCDR / VERSA-KWRL2 / VERSA-LCDM-WRL	11
6.3.3 Arming the selected partition.....	12
6.3.4 Quick arming	12
6.3.5 Arming without delay.....	12
6.3.6 Information about bypassed zones	12
6.3.7 Denial of arming and forced arming.....	13
6.3.8 Failure of arming procedure	13
6.4 Disarming and alarm clearing	14
6.4.1 Disarming and alarm clearing without partition selection.....	14
6.4.2 Disarming and alarm clearing with a proximity card VERSA-LCDR / VERSA-KWRL2 / VERSA-LCDM-WRL	14
6.4.3 Disarming and alarm clearing in selected partition	14
6.4.4 Viewing the zones which triggered alarm	14
6.5 Quick inspection of partition status	14
6.6 Triggering the alarm from keypad	14
6.7 Turning the CHIME on /off	15
6.8 User menu.....	15
6.8.1 Navigating through the menu and running functions	15
6.8.2 "Step by step" programming method	15
6.8.3 Entering data	16
6.8.4 User functions list.....	17
6.9 Change own code.....	18
6.10 Users.....	18
6.10.1 Adding a user	18
6.10.2 User editing	23
6.10.3 Removing a user	25
6.11 Canceling the telephone messaging	25
6.12 Zone bypassing	25
6.12.1 Zone inhibiting	25
6.12.2 Zone isolating	26
6.13 Viewing the event log	26
6.14 Auto-arming deferment.....	26
6.14.1 Simple auto-arming deferment.....	26
6.14.2 Auto-arming deferment by means of function	27
6.15 Setting the system time and date.....	27
6.16 Programming the timers	27
6.16.1 Programming the weekly schedule	27

6.16.2	Programming an exception	28
6.16.3	Selecting the arming mode	28
6.17	Programming the telephone numbers to be notified	28
6.18	Programming codes to acknowledge / clear messaging	29
6.19	Checking the troubles / system state	30
6.19.1	Information on system state	30
6.19.2	Trouble handling procedure	30
6.19.3	Trouble memory and clearing the trouble memory	30
6.20	Output control	30
6.20.1	Quick control of outputs	31
6.20.2	Controlling the outputs by means of proximity card VERSA-LCDR / VERSA-KWRL2 / VERSA-LCDM-WRL	31
6.20.3	Controlling the outputs by means of function	31
6.21	Tests	31
6.21.1	Zone test	31
6.21.2	Output test	32
6.21.3	Checking the level / quality of radio / cellular signal	32
6.21.4	Starting the manual test transmission	32
6.21.5	Telephone reporting test	32
6.21.6	Checking the firmware version of control panel	32
6.21.7	Checking the firmware version of modules	32
6.21.8	Checking the current supply voltage in modules	33
6.21.9	Outputs reset	33
6.22	Service	33
6.22.1	Defining the service access rules	33
6.22.2	Defining the service access time	34
6.22.3	Replacing batteries in wireless keypad	34
7.	Operating the alarm system by means of keyfob	34
7.1	Denial of arming	36
7.1.1	Forced arming	36
7.2	Failure of the arming procedure initiated from keyfob	36
8.	Operating the alarm system by telephone	36
8.1	Starting the operating by telephone	37
8.2	Voice menu	37
8.3	Ending the operating by telephone	38
9.	Acknowledgement of voice messaging	38
10.	SMS control	39
11.	VERSA CONTROL application	39
11.1	First start of the VERSA CONTROL application (Android)	40
11.1.1	Adding a new alarm system by using the QR code (Android)	40
11.1.2	Adding a new alarm system without using the QR code (Android)	41
11.2	First start of the VERSA CONTROL application (iOS)	42
11.2.1	Adding a new alarm system by using the QR code (iOS)	42
11.2.2	Adding a new alarm system without using the QR code (iOS)	43
12.	Manual update history	44

1. Introduction

Thank you for choosing the product offered by the SATEL Company. Wishing you full satisfaction with the choice you made, we are always ready to provide you with professional assistance and information on our products.

The SATEL Company is manufacturer of a broad range of devices dedicated for use in security alarm systems. Further information is available on our website www.satel.eu or at the points of sale offering our products.

This manual describes various ways of operating the alarm system, except by using the LED keypad and the touchscreen keypads (INT-TSG, INT-TSG2, INT-TSH and INT-TSH2), the description of which can be found in separate manuals.



It is recommended that the installers prepare their own user manual for the alarm system installed by them. The manual must include all changes and modifications in relation to the factory default settings.

The installer should train the users in the rules of operating the alarm system.

2. Technical reliability of the alarm system

A failure of any component of the alarm system will result in deterioration of the level of protection. Unfortunately, the devices which are installed outside (e.g. the outdoor sirens) are exposed to the adverse effects of weather. During storms, the devices connected to the electrical system or telephone line are vulnerable to damage as a result of atmospheric discharge.

The control panel is provided with a number of safeguards and automatic diagnostic features to test the system performance. Detection of irregularities is signaled by the  LED on the keypad. **You should immediately respond to such a signal, and, if necessary, consult the installer.**

In addition, some features designed for testing the alarm system are available in the control panel. They make it possible to check the detectors, sirens, telephone communicators, etc for correct functioning. **Only regular testing and inspection of the alarm system will allow you to keep a high level of protection against intrusion.**

It is recommended that the installer, at the request of the user, carry out periodic maintenance of the alarm system.

It is in the interest of the user to anticipate and plan in advance the procedures in case an alarm is set off by the control panel. It is important to be able to verify the alarm, determine its source and take appropriate actions (e.g. evacuation in the event of a fire alarm).

3. Alarm system operating costs

The control panel can inform the users and the monitoring station about the status of protected facility. Implementation of these tasks means financial costs. The amount of the costs incurred depends on the amount of information sent. A failure, as well as an incorrect programming of the control panel, may result in increased costs (due to making of excessive number of calls).

Please inform the installer, which is a priority: to deliver information at any cost, or to prevent excessive costs. For example, after an event code has failed to be sent successfully to the monitoring station, the control panel may repeat attempts every few minutes to send the code or to cease the attempts to send the code until a next event occurs.

4. Glossary

Alarm – reaction of the alarm system to detection by the detectors of an intruder in the protected area, or to another event within the protected area (e.g. glass pane break, gas detection, etc.). The alarm can be signaled in keypads, proximity card arm/disarm devices, or by sirens (during a defined time or until cleared). Additionally, information on the alarm can be sent to the monitoring station or the user.

Alarm zone – the zone whose violation can result in the alarm being triggered. The alarm zones can be either **instant** (violation will trigger the alarm at once) or **delayed** (violation will only trigger the alarm after a defined period of time has elapsed, e.g. the entry delay).

Armed mode – the status of alarm system in which zone violation will trigger the alarm.

Code – a sequence of digits that allows the user to operate the alarm system by using keypad.

Day armed mode – the status in which only some zones in the partition are armed, as selected by the installer. The installer should indicate the zones to be armed when a user stays in the protected area, but there is no risk of the zones being violated by the user during the daytime. If no such zones are indicated by the installer, the user will not be able to arm the partition in this mode.

Detector – the basic component of alarm system, which analyzes the environment and, if a situation recognized as a threat occurs, transmits appropriate information to the control panel (e.g. motion detectors on registering motion, magnetic contacts on opening the door/window, glass-break detectors on breaking glass pane, gas detectors on sensing gas, etc.).

Entry delay – time counted from the moment of entry into the protected area, which makes it possible to disarm the partition before the alarm is triggered.

Entry route – the route which the user must have to follow after entry into the protected area before being able to disarm the system. It is usually the same as the exit route.

Exit delay – time counted from the moment of starting the arming procedure in the partition, which makes it possible to leave the protected area before the alarm is triggered.

Exit route – the route which the user must have to take after arming before he leaves the protected area. It is usually the same as the entry route.

Fire alarm – alarm triggered by fire detectors, or from the keypad, in the event of fire.

Full armed mode – the status in which all zones belonging to the partition are armed.

Installer – the person who has installed and programmed the alarm system.

Medical (auxiliary) alarm – alarm triggered by means of a button, or from the keypad, if it is necessary to call the medical assistance.

Night armed mode – the status in which only some zones in the partition are armed, as selected by the installer. The installer should indicate the zones to be armed when a user stays in the protected area, but there is no risk of the zones being violated by the user at night. If no such zones are indicated by the installer, the user will not be able to arm the partition in this mode.

Panic alarm – alarm triggered by means of the panic button, or from the keypad, in case of a hold-up.

Partition – a part of the protected area, composed of a number of zones. The division into partitions makes it possible to limit the access to part of the premises to some selected users, and to arm/disarm the system only in part of the protected area.

Passive transponder – a wireless device which has no power supply of its own, but, under the action of electromagnetic field, it can emit a signal that enables the device to be identified. It can have the form of proximity card, proximity tag, etc.

Protected area – the area supervised by detectors being part of the alarm system.

Proximity card – a passive transponder that allows the user to operate the alarm system by means of a proximity card reader (INT-CR and INT-IT proximity card arm/disarm devices are provided with the reader).

Reporting – reporting events that occurred in the alarm system to the monitoring station. The information about occurrence of an event can be transmitted via telephone line, Ethernet network, etc. The companies offering the alarm system monitoring service undertake to intervene if specific events occur (e.g. alarms, troubles, etc.).

Service code – a code that allows access to the service mode, as well as some functions in the user menu.

Service technician – the person whose function is to control operability of the installed alarm system and its components, as well as to eliminate possible problems. These duties can be fulfilled by the installer or a person assigned by him.

Siren/beacon – a device providing information about alarms or other events in the alarm system by means of acoustic or optical signaling.

Tamper alarm – reaction of the alarm system to opening the housing of a device which is part of the alarm system, tearing off the device from the wall, cutting through the alarm system cables, etc. Actions taken by the alarm system may be similar as in the event of alarm, however, if the tamper alarm occurs, it is advisable to call in the installer so that he can make a checkup.

User – a person which can operate the alarm system, using a code, proximity card or remote control keyfob.

Warning alarm – in some situations, when the alarm criteria are met, the alarm system does not take up immediately all the actions provided for in the event of alarm. These actions are postponed, reaction of the system being limited to signaling warning alarm in keypads, proximity card arm/disarm devices or on indoor sirens/beacons. Thus the user who made a mistake when entering the protected area (failed to disarm the system before the entry delay expires), or moving around the area when the day or night armed mode is activated (violated the armed zone), has some extra time to disarm the system. Contact your installer to obtain detailed information on the situations when the alarm will be preceded by warning alarm.

Zone – **1.** a separated portion of the protected area that can supervised by a detector or detectors. **2.** the terminals on control panel/expander electronics board to which you can connect a detector or another device whose state is to be supervised (panic button, siren tamper contact, power supply output indicating loss of 230 V AC supply, etc.).

Zone bypassing (inhibiting / isolating) – procedure preventing the alarm from being triggered by the selected zone when it is in the armed mode. Violations of the zone will be ignored by the control panel.

Zone violation – a change of the zone status to another, different from that defined for the normal state (e.g. as a result of motion being sensed by the motion detector, gas being sensed by the gas detector, etc.).

5. Control panel compliance with EN 50131 standard requirements for Grade 2

If the installer has configured the control panel in compliance with the EN 50131 standard requirements for Grade 2:

1. The user codes should be composed of at least 5 characters.
2. The amount of information provided in the keypads by means of LEDs, display and sound signaling is limited.

- 3. The quick arming from keypad (without entering the code) is not available.
- 4. Arming may be impossible, if one of the situations provided for in the standard occurs (zone violation, trouble).

How requirements of the standard affect the use of the control panel is described in detail hereunder.

6. Operating the alarm system with LCD keypad

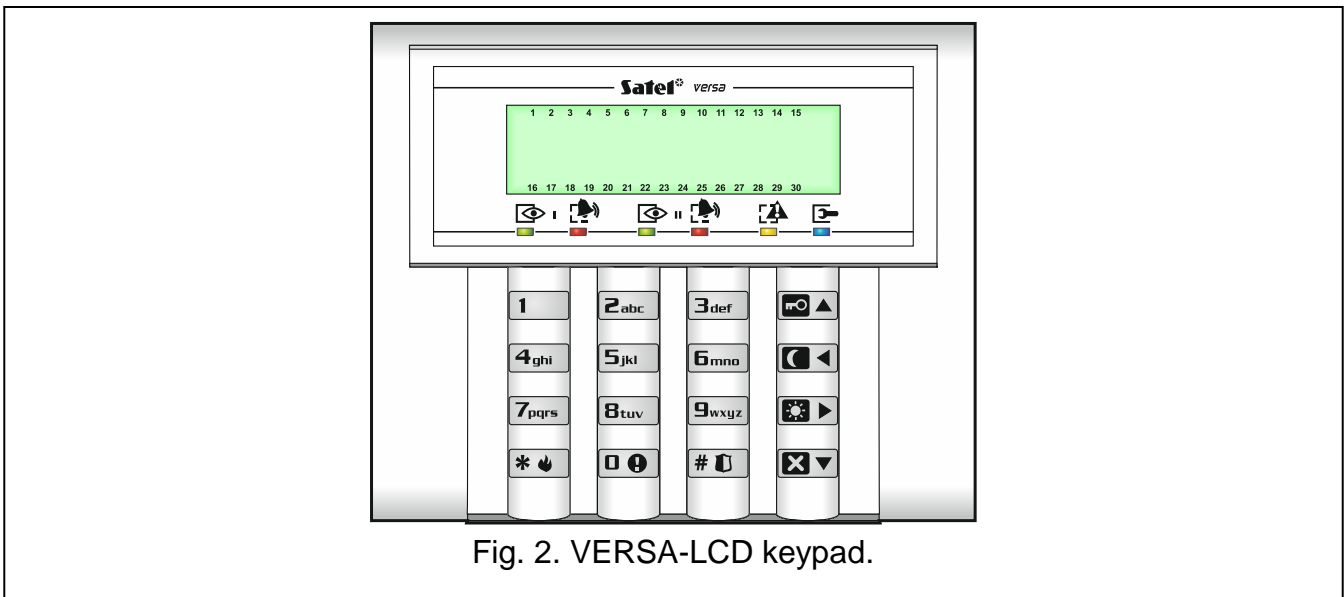
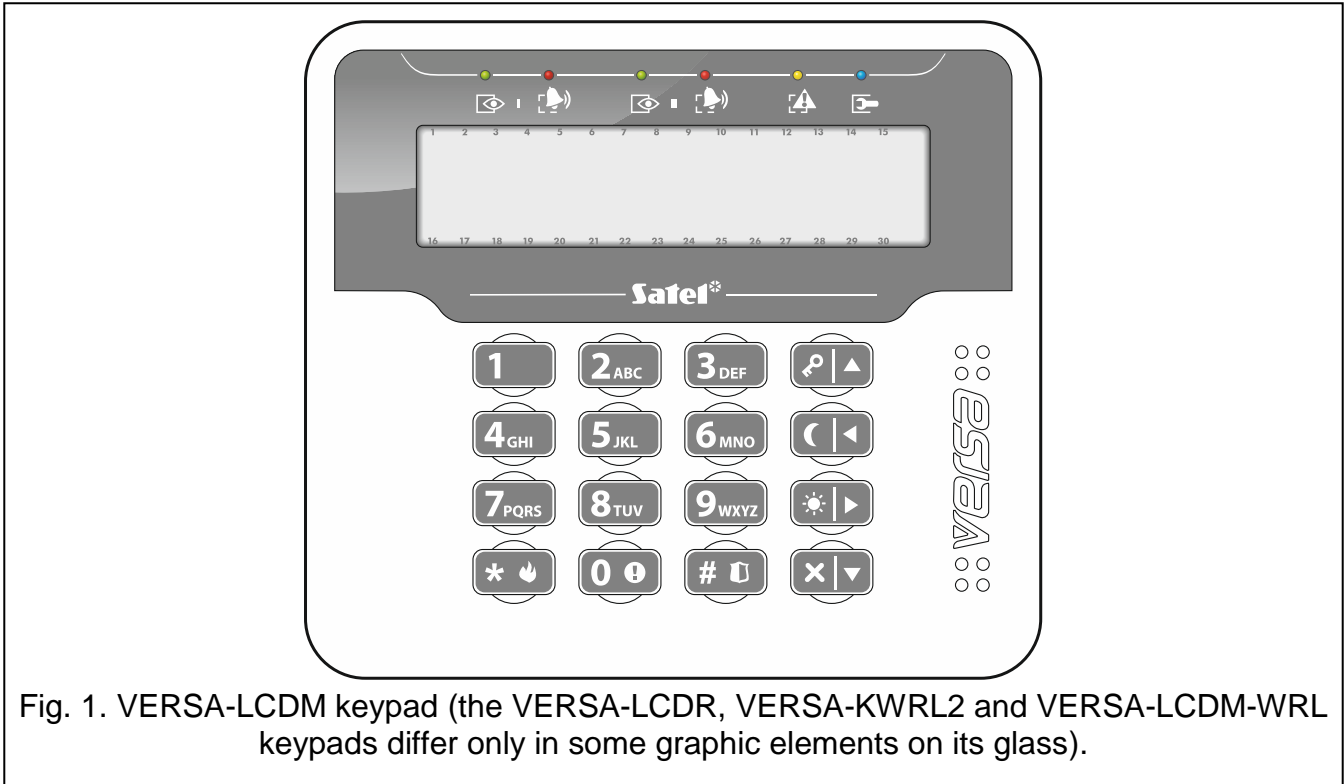

SATEL offers the following LCD keypads for VERSA Plus control panels:

VERSA-LCD – hardwired keypad,

VERSA-LCDM – hardwired keypad,

VERSA-LCDR – hardwired keypad with built-in proximity card reader,









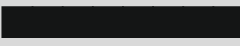

VERSA-KWRL2 – wireless keypad with built-in proximity card reader,

VERSA-LCDM-WRL – wireless keypad with built-in proximity card reader.

The keypads are available in a variety of color options for the display and key backlight. The color variant is indicated by the additional designation in the keypad name (e.g. VERSA-LCD-GR – green display and keys backlight; VERSA-LCDM-WH – white display and keys backlight).

6.1 Keypads description



6.1.1 LEDs presenting partition and system state



LED	Color	Description
	green	indicates the partition state (each partition has its own LED) ON – partition is armed flashing – exit delay countdown is running in partition
	red	indicates alarm or alarm memory in the partition (each partition has its own LED) The way of presenting the information is shown graphically below. The information is presented for 2 seconds and repeated (□ – LED is OFF; ■ – LED is ON). The higher position in the list means the higher priority of the presented status:  – fire alarm,  – burglary alarm,  – warning alarm,  – tamper alarm,  – fire alarm memory,  – burglary alarm memory,  – warning alarm memory,  – tamper alarm memory.
	yellow	flashing when the system requires user's attention (e.g. because of a trouble or trouble memory) The LED goes off, if one or both partitions are armed.
	blue	indicates the service mode ON – the service menu is available on the keypad flashing – the service menu is not available on the keypad (it is either available on another keypad or has been hidden by the installer)



Information about the armed state can be extinguished after a time period defined by the installer. Entering the code and pressing the  key will display again the armed state information.

If the GRADE 2 global option is enabled by installer:

- the  LEDs indicate alarms only after entering the code and pressing the  key,
- flashing of the  LED means that there is a trouble in the system, some zones are bypassed, or that there was an alarm.

When programming by means of the “step-by-step” method, the  and  LEDs present the number of the current step (see p. 15).









When you are using the user menu or service menu, the  LED is:

- flashing rapidly during navigation through the menus and submenus,
- steady on after a function is started.

6.1.2 Display

The display provides a number of data, facilitating communication between the alarm system and the user. The installer defines how the display will be backlit and selects the information to be shown on the display screen.





The display can work in normal mode or in zone presentation mode (the modes being toggled by means of the  key). When in the normal mode, the date and time (in installer defined format) or the keypad name are presented in the upper line of the display. In the zone presentation mode, symbols are displayed, showing the status of zones available in the system (where the control panel settings do not provide for detector presence at a zone, the status of the zone is not displayed). The numbers around the display correspond to the zone numbers. The symbols illustrate the following zone states (the higher position on the list, the higher priority of the presented state):

-  – inhibited (not displayed when armed),
-  – isolated (not displayed when armed),
-  – long violated (not displayed when armed),
-  – no violations (not displayed when armed),
-  – first triggered alarm,
-  – tampered (2EOL type zone),
-  – violated,
-  – tamper memory (2EOL type zone),
-  – alarm memory,
- – normal state.



If the global GRADE 2 option is enabled by the installer, switching the display over to the zone status presentation mode ( key) is impossible.

Irrespective of the selected mode, the occurrence of specific events may result in the following information being displayed (the higher position = the higher priority of the status presented):

- countdown of auto-arming delay,
- countdown of entry delay,
- countdown of exit delay,
- alarm from zone – the message contains the name of zone which triggered the alarm and remains displayed until the alarm is cleared (in case of alarm from several zones, messages about successive alarms are displayed alternately every 2 seconds – use the  or  key to scroll them through),
- alarm in partition – the message contains the name of partition where the alarm occurred and remains displayed until the alarm is cleared (if there is alarm in both partitions, messages about the alarm are displayed alternately every 2 seconds in the first and second partition – use the  or  key to scroll them through),
- there was a tamper and the service must be called in – the message is displayed until trouble memory is cleared by a person using the service code (see: “Trouble memory and clearing the trouble memory” p. 30).



If the GRADE 2 global option is enabled by the installer, the messages on alarms and tampers are not displayed.

6.1.3 Keys

The keys bearing digits and letters enable entering the code, as well as data when the keypad is being used.

Other functions of these keys and the basic function of the other keys are described below.



allows to trigger the medical (aux) alarm (press and hold down for 3 seconds)



allows to turn on/off the CHIME signal in the keypad (press and hold down for 3 seconds)



allows to toggle the LCD keypad display between the normal mode and the zone state presentation mode (press and hold down for 3 seconds)



allows to:

- arm in the full mode [if the system is disarmed and there is no alarm] or disarm the system and clear the alarm [if the system is armed and/or there is an alarm] (enter the code and press)
- trigger the panic alarm (press and hold down for 3 seconds)



allows to:

- open the user menu (enter the code and press)
- trigger the fire alarm (press and hold down for 3 seconds)



allows to arm in the full mode (see “Arming”)



allows to arm in the night mode (see “Arming”)



allows to arm in the day mode (see “Arming”)



allows to:

- disarm the system and clear the alarm (see “Disarming and alarm clearing”)
- quickly check the partition state (press and hold down for 3 seconds)

6.1.4 Built-in proximity card reader

The VERSA-LCDB, VERSA-KWRL2 and VERSA-LCDM-WRL keypads have a built-in proximity card reader. You can use proximity cards (tags or other 125 kHz passive transponders) to:

- arm the system,
- disarm the system and/or clear alarm,
- toggle the state of the devices connected to the alarm system outputs.

6.1.5 Sound signaling





The installer can disable the sound signaling.

Beeps generated when operating

1 short beep – pressing any number key.

3 short beeps – confirmation of:





- starting the arming procedure (there is exit delay in the partition) or arming (there is no exit delay in the partition),

- disarming and/or alarm clearing,
- selecting the partition which is to be armed or disarmed, or where alarm is to be cleared
 - in such a case the keypad is waiting for the code to be entered,
- turning output off,
- turning off the CHIME in the keypad, using the  key,
- switching over the display from the normal mode to the zone status presentation mode, and vice versa, by means of the  key.

4 short beeps and 1 long beep – confirmation of:

- turning output on,
- turning on the CHIME in the keypad, using the  key.

1 long beep – some zones are bypassed (when arming) or denial of arming (some zones in the partition are violated or there is a trouble).

2 long beeps – incorrect code / card or pressing the , , ,  or  key, if not preceded by entering code or selecting a partition.

3 long beeps – refusal to carry out a command (the user does not have the required authority level or the function is not available).

Beeps generated during programming

1 short beep – pressing any number key.

2 short beeps – entering the user menu, submenu or a function, or going to a next programming step.

3 short beeps – end of timer parameters editing, exiting the service function on pressing the  key.

4 short beeps and 1 long beep – termination of the user function on pressing the  key, or quitting the service mode.

2 long beeps – exiting the function on pressing the  key, or an unavailable function.

Events signaled by sounds



Only installer selected events are signaled.

Duration of the alarm signaling is to be defined by the installer.

If the GRADE 2 option is enabled by installer, the keypad will not signal by sounds any new troubles and alarms.

5 short beeps – zone violation (CHIME).

Long beep every 3 seconds, followed by a series of short beeps for 10 seconds and 1 long beep – countdown of exit delay (if the time is shorter than 10 seconds, only the final sequence of short beeps will be generated).

A sequence of 7 beeps of diminishing duration, repeated every few seconds – countdown of auto-arming delay.

2 short beeps every seconds – countdown of entry delay.

2 short beeps every 3 seconds – signaling a new trouble.

Short beep every 0.5 seconds – warning alarm.

Continuous beep – alarm.

Long beep every second – fire alarm.

6.2 Codes

Operating the alarm system by means of the keypad is possible after entering the code. Only some functions can be run without the code being entered.



Do not make your code available to other people.

Using an incorrect code three times may:

- *trigger an alarm,*
- *block the keypad for 90 seconds.*

As long as the keypad is blocked, entering the correct code is treated as entering an incorrect code ("Wrong code" message is displayed).

6.2.1 Factory default codes

By default, the following codes are preprogrammed in the control panel:

user 30 code: 1111

service code: 12345



The factory default codes should be changed before you start using your alarm system (see: "Change own code").

6.3 Arming

Completion of the steps below will start the arming procedure. The procedure ends when the exit delay time elapses (if the countdown is completed successfully, the system becomes armed – see also "Failure of arming procedure" p. 13). If the exit delay time is 0, the system becomes armed instantly.

You can change the arming mode, which means you do not have to disarm the system to set the partition to another arming mode. In the case of alarm, changing the arming mode or re-activating the same arming mode will result in clearing the alarm (it does not apply to the quick arming mode).



The day/night arming modes are available if the installer has defined which zones are to be active in this armed mode.

If exit delay is programmed for a partition, you can leave the partition through the exit route without triggering alarm after the partition arming procedure has started. The exception is when the partition is armed without exit delay.

6.3.1 Arming without partition selection

Enter the code, and then press:



- to arm in full mode,



- to arm in day mode,



- to arm in night mode.

The partitions to which you have access will be armed.

6.3.2 Arming with proximity card **VERSA-LCDDR / VERSA-KWRL2 / VERSA-LCDM-WRL**

You can use one of the following methods to arm the system (consult with the installer which method is to be used):







- bring the card close to the keys and move it away,

- bring the card close to the keys and hold it there for about 3 seconds.

The partitions to which you have access will be armed in full mode.

 *The reader in wireless keypad works when the keypad is in the wake-up mode.*







6.3.3 Arming the selected partition

1. Indicate the partition which is to be armed (press one of the keys:  - partition 1;  - partition 2).
2. Select the arming mode (press one of the keys:  - full arming;  - day arming;  - night arming). Backlight of the keys will start flashing, which indicates that the code must be entered.
3. Enter the code.
4. Press the  key or press again the key corresponding to the selected arming mode.

 *When the quick arming is available, the steps 3 and 4 are skipped.*

6.3.4 Quick arming



The installer may permit arming without entering the code.

1. Indicate the partition(s) to be armed (press one of the keys:  - partition 1;  - partition 2;  or  - both partitions).
2. Select the arming mode (press one of the keys:  - full arming;  - day arming;  - night arming).

 *You can switch the arming mode from the night mode to the full mode and from the day mode to the full mode without entering the code. Otherwise, you will have to enter the code – see “Arming the selected partition”.*

The installer can configure the system so that the quick arming can be impossible, if there is a violated zone in the partition, or a trouble has occurred in the system.

6.3.5 Arming without delay

When arming the system using one of the above mentioned methods, press and hold down the arming mode selection key (,  or ) for about 3 seconds. The system will become armed without delay, i.e. the delayed zones will act as instant ones (without any exit/entry delay time).

 *In the day or night arming mode, the entry delay countdown may run, if the control panel is so configured by the installer.*



6.3.6 Information about bypassed zones

During an arming attempt you may get a message about bypassed zones in the partition. The information will be displayed, if:



- the control panel has been suitably configured by the installer,
- you have the INSPECTION right.

The message is displayed in the following form:

“Bypassed zones 1=Arm 4=Bypasses” – if you have the ZONE INHIBITION right. You can:

- press the  key to cancel the arming,
- press the  key to proceed with the arming,
- press the  key to start the INHIBIT function (see: “Zone inhibiting” p. 25).

“**Bypassed zones 1=Arm**” – if you don’t have the ZONE INHIBITION right. You can:



- press the  key to cancel the arming,
- press the  key to proceed with the arming.





6.3.7 Denial of arming and forced arming

The installer can configure the control panel so that initiating the arming procedure is impossible, if:

- in the partition to be armed, at least one zone that must not be violated during arming (the PRIORITY option has been enabled for the zone by the installer) is violated,
- in the partition to be armed, at least one alarm zone is violated beyond the exit route,
- there is trouble in the system.

If you have the INSPECTION right, you will be informed about the cause of refusal to arm the system (the order of message descriptions corresponds to their priority):









“**Zone [zone number] violat.**” – a zone with enabled PRIORITY option is violated. If two or more such zones are violated, the ↓ indicator will be flashing on the display. To scroll through the list of violated zones, use the  and  keys. You can:

- press the  key to cancel the arming,
- press the  key to inhibit the violated zone (you must have the ZONE INHIBITION right). A message will be displayed, prompting you to confirm the command to inhibit the zone (press  to inhibit the zone, or  to cancel inhibiting the zone).





The system can be armed after eliminating the cause of the zone violation, or after bypassing the zone.

“**Violated zones 1=Ok 2=Check**” – an alarm zone outside of the exit route is violated. You can:

- press the  key to cancel the arming,
- press the  key to force the arming,
- press the  key to check which zone is violated. If two or more such zones are violated, the ↓ indicator will be flashing on the display. To scroll through the list of violated zones, use the  and  keys. If you have the ZONE INHIBITION permission, you will be able inhibit the violated zone by pressing . A message will be displayed, prompting you to confirm the command to inhibit the zone (press  to inhibit the zone, or  to cancel inhibiting the zone).

“**Troubles 1=Ok 2=Check**” – there is a trouble in the system. You can:

- press the  key to cancel the arming,
- press the  key to force the arming,
- press the  key to view the trouble log – the 7. SYSTEM STATE function will start (see: “Checking the troubles / system state” p. 30).



Information on the forced arming is written into the event log.

6.3.8 Failure of arming procedure

The installer can configure the alarm system in such a manner that it will not be armed, if at the moment of completing the exit delay countdown:

- there is a violated zone in partition which was not violated when the arming procedure was started,
- there is a trouble which did not exist when the arming procedure was started.

6.4 Disarming and alarm clearing

Disarming and alarm clearing are carried out in the same way, the procedures being interconnected. If the partition is armed and an alarm is triggered in it, then disarming will also mean alarm clearing.



In order to clear the alarm without disarming the partition, arm again the partition in the same mode (see: “Arming” p. 11).

6.4.1 Disarming and alarm clearing without partition selection

Enter the code and then press the key. Disarming / alarm clearing will take place in the partitions to which you have access.

6.4.2 Disarming and alarm clearing with a proximity card **VERSA-LCDR / VERSA-KWRL2 / VERSA-LCDM-WRL**

Bring the card close to the keys and move it away. Disarming / alarm clearing will take place in the partitions to which you have access.



The reader in wireless keypad works when the keypad is in the wake-up mode.

6.4.3 Disarming and alarm clearing in selected partition

1. Indicate partition which is to be disarmed and/or where alarm is to be cleared (press one of the keys: - partition 1; - partition 2).
2. Press the key. Backlight of the keys will start flashing, which indicates that the code must be entered.
3. Enter the code.
4. Press the or key.

6.4.4 Viewing the zones which triggered alarm

Having cleared the alarm, you can check which zones triggered the alarm (this does not apply to the TMP zone of the control panel). The information will be available until viewing the zones or arming the system.

1. Enter the code and press .
2. The “View cleared zones? 1=Yes” will appear on the display. Press .
3. The list of zones which triggered the alarm will be displayed.
4. Having viewed the list, press (the user menu will be displayed).

6.5 Quick inspection of partition status

If such an option is provided by the installer, pressing and holding down the key for about 3 seconds will display information on the partition state (whether it is armed and what type of arming mode is set). At the same time, the LED will come on. In the upper line, a message about the first partition state is displayed, and in the lower line – about the second partition state.

To terminate the function of partition state presentation, press . The keypad will quit the function automatically after 2 minutes.

6.6 Triggering the alarm from keypad

The installer can permit triggering alarms from the keypad. To trigger an alarm, do the following:

fire alarm – press for approx. 3 seconds,

medical (auxiliary) alarm – press  for approx. 3 seconds,

panic alarm – press  for approx. 3 seconds. The installer defines whether the loud panic alarm (setting off the loud alarm signal) or the silent panic alarm (without the loud signal) will be triggered.

6.7 Turning the CHIME on /off

The CHIME is five short sounds by means of which the keypad will inform you e.g. that a door / window is open, when the system is disarmed. The installer defines which zones of the alarm system can trigger the CHIME and whether it can be turned on/off by the users.

Press and hold down  for about 3 seconds to turn on or off the CHIME signaling.







6.8 User menu

Enter the code and press  to get access to the user menu. The functions you can run will be displayed. The list of available functions depends on your rights, as well as on the state and configuration of the system.



In order to quit the function and/or user menu, press . The keypad will quit the menu automatically, if 2 minutes have elapsed since the last keypress.



6.8.1 Navigating through the menu and running functions



Using the arrow keys

- Using the  and  keys, find the required submenu or function. The currently selected submenu or function is indicated by the cursor on the left (the submenu indicating cursor: ; the function indicating cursor: ).
- Press  or  to open a submenu or run a function (use the  key to go back to the previous menu/submenu).

Using the digit shortcuts

All submenus and functions are numbered. In order to enter a submenu, just press the key with number corresponding to the submenu number. In order to start a function, press the key with number corresponding to the function number, and then . You can quickly start the selected function by entering at once a sequence of some digits (corresponding to the consecutive submenu numbers and the function number) and pressing .



For example, to start the zone inhibiting function, enter the user menu and then press   , where:

-  - entering the 4. BYPASSES submenu,
-   - running the 1. INHIBIT function.



Remember that the sequence of digits which starts a function e.g. from the main menu level will not start the same function from the submenu level.

6.8.2 “Step by step” programming method

In case of some functions (e.g. adding and editing users, configuring timers, etc.), the programming is effected by using the “step by step” method. After calling the function and selecting the item to be configured from the list, the first parameter available for programming will be displayed. After pressing , you will go on to programming another parameter (if you have entered some changes, they will be saved). After all parameters have been configured, you will either return to the selection list or exit the user menu, depending on the function. The  and  LEDs of the first and second partition show the number of programming step (see: table 1). Some programming steps may be sometimes not available.

LED status				Number of programming step
<input type="checkbox"/>	<input type="checkbox"/>	<input type="checkbox"/>	<input checked="" type="checkbox"/>	1
<input type="checkbox"/>	<input type="checkbox"/>	<input checked="" type="checkbox"/>	<input type="checkbox"/>	2
<input type="checkbox"/>	<input type="checkbox"/>	<input checked="" type="checkbox"/>	<input checked="" type="checkbox"/>	3
<input type="checkbox"/>	<input checked="" type="checkbox"/>	<input type="checkbox"/>	<input type="checkbox"/>	4
<input type="checkbox"/>	<input checked="" type="checkbox"/>	<input type="checkbox"/>	<input checked="" type="checkbox"/>	5
<input type="checkbox"/>	<input checked="" type="checkbox"/>	<input checked="" type="checkbox"/>	<input type="checkbox"/>	6
<input type="checkbox"/>	<input checked="" type="checkbox"/>	<input checked="" type="checkbox"/>	<input checked="" type="checkbox"/>	7
<input checked="" type="checkbox"/>	<input type="checkbox"/>	<input type="checkbox"/>	<input type="checkbox"/>	8
<input checked="" type="checkbox"/>	<input type="checkbox"/>	<input type="checkbox"/>	<input checked="" type="checkbox"/>	9
<input checked="" type="checkbox"/>	<input type="checkbox"/>	<input checked="" type="checkbox"/>	<input type="checkbox"/>	10

Table 1. The manner of indicating the programming step (- LED OFF; - LED ON).

6.8.3 Entering data

The changes entered will be saved after pressing the key. Use the key to quit the function without saving changes.

Entering digits

To enter digits, use the numeric keys.

Entering hexadecimal characters

To enter digits, use the numeric keys, and to enter characters from A to F, use the and keys (keep pressing the key until the required character appears).



Entering names

The characters that can be entered by using the keys are presented in Table 2. Keep pressing the key until the required character appears. Long press the key to display the digit assigned to it.

Key	Characters available after next keystroke																	
	!	?	'	`	←	"	{	}	\$	%	&	@	\	^			#	1
	a	b	c	2														
	d	e	f	3														
	g	h	i	4														
	j	k	l	5														
	m	n	o	6														
	p	q	r	s	7													
	t	u	v	.														8
	w	x	y	z	9													
	.	,	:	;	+	-	*	/	=	_	<	>	()	[]	0	

Table 2. Characters available when entering names. The upper case letters are available under the same keys (to change the letter case, press).

Shown on the left side in the upper line of the display is information about the letter case: [Abc], [ABC] or [abc] (it will be displayed after pressing any key and will be visible for a few seconds after the last keystroke).

The  key moves the cursor to the right, and the  key – to the left. The  key deletes the character on the left side of the cursor.

6.8.4 User functions list

Shown in square brackets are key sequences that enable calling the given submenu or starting the given function from the main menu level. The functions that are only available after entering the service code have been specially highlighted (white text against black background). The access to other functions depends on the user rights. Highlighted with a frame are the functions which are available or change the operating mode, if the GRADE 2 option has been enabled by the installer.

[1#]	1. Change code	<i>changing own code</i>
[2]	2. Users	
	[21#] 1. New user	<i>adding new user</i>
	[22#] 2. Edit user	<i>editing user</i>
	[23#] 3. Remove user	<i>removing user</i>
[3#]	3. Abort v.msg.	<i>canceling telephone messaging</i>
[4]	4. Bypasses	
	[41#] 1. Inhibit	<i>inhibiting zones</i>
	[42#] 2. Isolate	<i>isolating zones</i>
[5#]	5. Event log	<i>viewing events</i>
	[5#1#] 1. All	<i>viewing all events</i>
	[5#2#] 2. Grade2 backup	<i>viewing events required for Grade 2</i>
[6]	6. Settings	
	[61#] 1. A-arm defer.	<i>auto-arming deferment</i>
	[62#] 2. RTC clock	<i>programming the clock</i>
	[63#] 3. Timers	<i>programming the timers</i>
	[64#] 4. Tel. numbers	<i>programming telephone numbers to be notified</i>
	[65#] 5. Msg.clr.codes	<i>programming codes to acknowledge / clear messaging</i>
[7#]	7. System state	<i>checking troubles / checking partition, alarm, trouble status</i>
[8#]	8. Control	<i>controlling the outputs</i>
[9]	9. Tests	
	[91#] 1. Zone test	<i>starting zone test</i>
	[92#] 2. Output test	<i>starting output test</i>
	[93#] 3. Wrls/GSM sig.	<i>checking radio / cellular signal level</i>
	[94#] 4. Manual MS tst	<i>starting manual test transmission</i>
	[95#] 5. MS1 test	<i>test of telephone reporting to station 1</i>
	[96#] 6. MS2 test	<i>test of telephone reporting to station 2</i>
	[97#] 7. VERSA version	<i>checking firmware version of control panel</i>

[98#]	8. Expander ver.	<i>checking firmware version of system modules</i>
[99#]	9. Supply volt.	<i>checking current supply voltage in modules</i>
[90#]	0. Outputs reset	<i>deactivating outputs / activating 21. DETECTORS RESETTING output</i>
[0]	0. Service	
[00#]	0. Service mode	<i>starting service mode</i>
[01#]	1. Start DwnlTEL	<i>starting programming via PSTN communicator</i>
[02]	2. Start DwnlGSM	
[021#]	1. GSM audio	<i>starting programming via LTE communicator (300 bps)</i>
[03#]	3. Start DwnlUSB	<i>starting local programming</i>
[04#]	4. FinishDwnlUSB	<i>finishing local programming</i>
[05#]	5. Serv. access	<i>defining service code access rules</i>
[06#]	6. Access time	<i>defining service code access time</i>
[07#]	7. ETHM-1→DLOADX	<i>starting programming via Ethernet</i>
[08#]	8. GPRS→DLOADX	<i>starting programming via cellular data network</i>
[09#]	9. Replace bat.	<i>enabling batteries replacement in wireless keypad</i>



6.9 Change own code

1. Enter the user menu and press in turn .
2. Enter the new code, and then press .

6.10 Users

There can be up to 30 users in the system. A person using the service code (installer / service technician), who is an additional user, has a special status, but his/her access can be limited (see: "Defining the service access rules" p. 33 and "Defining the service access time" p. 34).

6.10.1 Adding a user

1. Enter the user menu and press in turn . Adding the user is effected by the "step by step" method, hence the programming step number is presented on the  and  LEDs of the first and second partitions (see: page 16, Table 1).



You can press to interrupt the procedure of adding a user. If the procedure is interrupted in step 5 or a next one (the code, user schedule and partitions have been already assigned to the user), the user will be added.

2. **Step 2. Entering new user code.** Information on the number of the user to be added is presented in the display upper line. Enter the new user's code, and then press .
3. **Step 3. Selecting user schedule.** Five installer defined schedules are available. The schedule determines the user's rights and the default operating mode of the remote control keyfobs assigned to the user (the keyfobs are added in subsequent steps). Press the key bearing the digit corresponding to the schedule which is to be assigned to the user. The name of selected schedule will appear in the lower display line. Press to confirm your selection.

Right	Schedule name and number				
	Usual	Simple	Arm only	DURESS	Administrator
	1	2	3	4	5
Arming	✓	✓	✓	✓	✓
Disarming	✓	✓		✓	✓
Alarm clearing	✓	✓		✓	✓
Telephone messaging clearing	✓				✓
Auto-arming defer	✓				✓
Zone inhibition	✓				✓
Zone isolation					✓
Change access code	✓	✓			✓
Users editing					✓
Control	✓	✓			✓
Programming					✓
DOWNLOAD/SERWIS					✓
Inspection	✓				✓
Tests					✓
DURESS				✓	
INT-VG access	✓				✓

Table 3. Factory default settings of the user schedules. The installer can change the names of schedules and assign other rights to them.



Using the DURESS right code will trigger a silent alarm, which is not signaled in any way, but the alarm code will be sent to the monitoring station.

4. **Step 4. Selecting partitions accessible to the user.** Press the key **1** (partition 1), **2_{abc}** (partition 2) or **3_{def}** (both partitions) to define the partitions to which the user is to have access. Information on the selected partition(s) will appear in the lower display line. Press **# 0** to confirm your selection.
5. **Step 5. Adding 433 MHz keyfob.** If the INT-RX-S, INT-RX or VERSA-MCU module is connected to the control panel, the user may be assigned a 433 MHz keyfob. Press in turn **1** and **# 0** (if a keyfob is to be assigned to the user) or **# 0** only (if no keyfob is to be assigned to the user).
6. **Step 5a. Selecting 433 MHz keyfob addition method.** Press **# 0** (if the keyfob serial number is to be entered) or press in turn **1 # 0** (if the serial number is to be read by the device which supports the keyfobs during transmission).
7. **Step 5b. Adding 433 MHz keyfob.** Depending on the selected method:
 - enter the keyfob serial number and press **# 0**,
 - press twice any button on the keyfob (displayed messages will prompt you what to do).



Numbering of the buttons in 433 MHz keyfobs is described in section “Operating the alarm system by means of keyfob” (p. 34).

8. **Step 5c. Assigning function to 433 MHz keyfob button 1.** Press **#**  to confirm the default function (defined by the installer in the user schedule) or enter the number of one of the following functions, and then press **#** :
0. Not used
 1. Zone 1 violation
 2. Zone 2 violation
 3. Zone 3 violation
 4. Zone 4 violation
 5. Zone 5 violation
 6. Zone 6 violation
 7. Zone 7 violation
 8. Zone 8 violation
 9. Zone 9 violation
 10. Zone 10 violation
 11. Zone 11 violation
 12. Zone 12 violation
 13. Zone 13 violation
 14. Zone 14 violation
 15. Zone 15 violation
 16. Zone 16 violation
 17. Zone 17 violation
 18. Zone 18 violation
 19. Zone 19 violation
 20. Zone 20 violation
 21. Zone 21 violation
 22. Zone 22 violation
 23. Zone 23 violation
 24. Zone 24 violation
 25. Zone 25 violation
 26. Zone 26 violation
 27. Zone 27 violation
 28. Zone 28 violation
 29. Zone 29 violation
 30. Zone 30 violation
 31. Arming partition 1 – full armed mode
 32. Arming partition 1 – night armed mode
 33. Arming partition 1 – day armed mode
 34. Disarming / clearing alarm in partition 1
 35. Arming partition 2 – full armed mode
 36. Arming partition 2 – night armed mode
 37. Arming partition 2 – day armed mode
 38. Disarming / clearing alarm in partition 2
 39. Arming partitions 1 and 2 – full armed mode
 40. Arming partitions 1 and 2 – night armed mode
 41. Arming partitions 1 and 2 – day armed mode
 42. Disarming / clearing alarm in partitions 1 and 2
 43. Loud panic alarm
 44. Silent panic alarm
 45. Fire alarm
 46. Medical alarm

51. Output 1 activation
52. Output 2 activation
53. Output 3 activation
54. Output 4 activation
55. Output 5 activation
56. Output 6 activation
57. Output 7 activation
58. Output 8 activation
59. Output 9 activation
60. Output 10 activation
61. Output 11 activation
62. Output 12 activation

71. Output 1 deactivation
72. Output 2 deactivation
73. Output 3 deactivation
74. Output 4 deactivation
75. Output 5 deactivation
76. Output 6 deactivation
77. Output 7 deactivation
78. Output 8 deactivation
79. Output 9 deactivation
80. Output 10 deactivation
81. Output 11 deactivation
82. Output 12 deactivation

91. Output 1 switchover
92. Output 2 switchover
93. Output 3 switchover
94. Output 4 switchover
95. Output 5 switchover
96. Output 6 switchover
97. Output 7 switchover
98. Output 8 switchover
99. Output 9 switchover
100. Output 10 switchover
101. Output 11 switchover
102. Output 12 switchover









Contact the installer to obtain information on the zone types and output functions.

9. **Step 5d. Assigning function to 433 MHz keyfob button 2.** Proceed in the same way as in Step 5c.
10. **Step 5e. Assigning function to 433 MHz keyfob button 3.** Proceed in the same way as in Step 5c.
11. **Step 5f. Assigning function to 433 MHz keyfob button 4.** Proceed in the same way as in Step 5c.
12. **Step 5g. Assigning function to 433 MHz keyfob button 5** (two buttons pressed simultaneously – see: “Operating the alarm system by means of keyfob” p. 34). Proceed in the same way as in Step 5c.

13. **Step 5h. Assigning function to 433 MHz keyfob button 6** (two buttons pressed simultaneously – see: “Operating the alarm system by means of keyfob” p. 34). Proceed in the same way as in Step 5c.

i | Pressing the  key between Step 5a and Step 5h will cancel the keyfob adding, but will not terminate the user adding procedure.

14. **Step 6. Adding APT-200 / APT-100 keyfob.** If the ABAX 2 / ABAX wireless system controller is connected to the control panel, the bidirectional APT-200 / APT-100 keyfob can be assigned to the user. Press in turn  and  (if a keyfob is to be assigned to the user) or  only (if no keyfob is to be assigned to the user).

15. **Step 6a. Selecting APT-200 / APT-100 keyfob addition method.** Press  (if the keyfob serial number is to be entered) or press in turn   (if the serial number is to be read by the ABAX 2 / ABAX wireless system controller during transmission).

16. **Step 6b. Adding APT-200 / APT-100 keyfob.** Depending on the selected method:
– enter the keyfob serial number and press ,

– press twice any button on the keyfob (displayed messages will prompt you what to do).
i | Numbering of the buttons and LEDs on the APT-200 / APT-100 keyfobs is described in section “Operating the alarm system by means of keyfob” (p. 34).

17. **Step 6c. Assigning function to APT-200 / APT-100 keyfob button 1.** Proceed in the same way as in Step 5c.



18. **Step 6d. Assigning function to APT-200 / APT-100 keyfob button 2.** Proceed in the same way as in Step 5c.

19. **Step 6e. Assigning function to APT-200 / APT-100 keyfob button 3.** Proceed in the same way as in Step 5c.

20. **Step 6f. Assigning function to APT-200 / APT-100 keyfob button 4.** Proceed in the same way as in Step 5c.

21. **Step 6g. Assigning function to APT-200 / APT-100 keyfob button 5.** Proceed in the same way as in Step 5c.

22. **Step 6h. Assigning function to APT-200 / APT-100 keyfob button 6** (two buttons pressed simultaneously: 1 and 5). Proceed in the same way as in Step 5c.

23. **Step 6i. Selecting confirmation for LED 1 in APT-200 / APT-100 keyfob.** Press  to confirm the default method of confirmation (defined by the installer in the user schedule) or enter the number of one of the following functions and then press :

- 0. On *LED is ON, when the control panel has acknowledged receiving information on pressing a button*
- 1. Output 1 state *LED is ON, when the selected output is active*
- 2. Output 2 state
- 3. Output 3 state
- 4. Output 4 state
- 5. Output 5 state
- 6. Output 6 state
- 7. Output 7 state
- 8. Output 8 state
- 9. Output 9 state
- 10. Output 10 state
- 11. Output 11 state
- 12. Output 12 state
- 13. Arming: Partition 1 *LED is ON when partition 1 is armed*

14. Arming: Partition 2	LED is ON when partition 2 is armed
15. Arming: Partition 1 or 2	LED is ON when partition 1 or 2 is armed
16. Arming: Partition 1 and 2	LED is ON when partitions 1 and 2 are armed
17. Partition 1 – Full arm	LED is ON when partition 1 is armed in full mode
18. Partition 1 – Night arm	LED is ON when partition 1 is armed in night mode
19. Partition 1 – Day arm	LED is ON when partition 1 is armed in day mode
20. Partition 2 – Full arm	LED is ON when partition 2 is armed in full mode
21. Partition 2 – Night arm	LED is ON when partition 2 is armed in night mode
22. Partition 2 – Day arm	LED is ON when partition 2 is armed in day mode
23. Partition 1 – Alarm	LED is ON when there is alarm in partition 1
24. Partition 2 – Alarm	LED is ON when there is alarm in partition 2
25. Partition 1 or 2 – Alarm	LED is ON when there is alarm in partition 1 or 2
26. Trouble	LED is ON when there is trouble in the system
27. Partition 1 – Not armed	LED is ON when partition 1 is disarmed
28. Partition 2 – Not armed	LED is ON when partition 2 is disarmed
29. Partition 1+2 – Not armed	LED is ON when partitions 1 and 2 are disarmed

255. NOT PRESENT

LED will not be used for confirmation



Contact the installer to obtain information on the zone types and output functions.

24. **Step 6j. Selecting confirmation for LED 2 in APT-200 / APT-100 keyfob.** Proceed in the same way as in Step 6i.

25. **Step 6k. Selecting confirmation for LED 3 in APT-200 / APT-100 keyfob.** Proceed in the same way as in Step 6i.



Pressing the key between Step 6a and 6k will cancel the keyfob adding, but will not terminate the user adding procedure.

26. **Step 7. Adding proximity card.** If a device provided with proximity card reader is installed in the system, a proximity card can be assigned to the user. Press in turn and (if a proximity card is to be assigned to the user) or only (if no proximity card is to be assigned to the user).

27. **Step 7a. Selecting card addition method.** Press (if the card code is to be entered) or select the device, by means of which the card code will be read. Use the and keys to scroll through the list of devices. Having selected the device, press .

28. **Step 7b. Adding proximity card.** Depending on the selected method:

- enter the card code (see: “Entering hexadecimal characters” p. 16) and press ,
- bring the card twice close to the reader (displayed messages will prompt you what to do). Remember that the card number will only be sent by the proximity card arm/disarm device after the card is moved away from the reader.









Pressing the key in Step 7a or 7b will cancel the card adding, but will not terminate the user adding procedure.







29. **Step 8. Giving name to user.** Enter the user name (see: “Entering names” p. 16) and press .

6.10.2 User editing

1. Enter the user menu and press in turn . User editing is effected by the “step by step” method, hence the programming step number is presented on the and LEDs of the first and second partitions (see: page 16, Table 1).

2. **Step 1. Selecting user whose data are to be edited.** You can make your selection by scrolling through the list of users by means of the  and  keys or entering the user number. Having selected the user, press .







 You can press  to interrupt the procedure of editing a user. Any changes made in the steps ended by pressing the  key will be saved.

3. **Step 2. Changing user code.** Proceed in the same way as when adding a new user.
4. **Step 3. Selecting user schedule.** Proceed in the same way as when adding a new user.
5. **Step 4. Selecting partitions accessible to the user.** Proceed in the same way as when adding a new user.
6. **Step 5. Editing 433 MHz keyfob.** Press:
- , if you want to move on to the next step,
 -  and  in turn, if you want to add a keyfob (the procedure is similar to that for adding a 433 MHz keyfob to a new user, however, if the user had a keyfob before, the control panel, during assignment of functions to the buttons, will suggest the same functions as were assigned to the removed keyfob),
 -  and  in turn, if the user has a keyfob and you want to edit functions assigned to the keyfob buttons (the procedure is similar to that for assigning functions after a 433 MHz keyfob has been added to a new user),
 -  and  in turn, if you want to remove a keyfob.

 Removal of the keyfob does not erase its settings (functions assigned to the keyfob).



The installer can remove all the 433 MHz keyfobs and their settings by using the REM.RX K-FOBS function (SERVICE MODE ►2. HARDWARE ►1. KPDS. & EXPS. ►9. REM.RX K-FOBS).

7. **Step 6. Editing APT-200 / APT-100 keyfob.** Press:

- , if you want to move on to the next step,
-  and  in turn, if you want to add a keyfob (the procedure is similar to that for adding the APT-200 / APT-100 keyfob to a new user, however, if the user had a keyfob before, the control panel, when assigning functions to the buttons and defining the rules of confirmation, will suggest the same settings as for the removed keyfob),
-  and  in turn, if the user has a keyfob and you want to edit functions assigned to the keyfob buttons (the procedure is similar to that for assigning functions after an APT-200 / APT-100 keyfob has been added to a new user),
-  and  in turn, if you want to remove a keyfob.

 Removal of the keyfob does not erase its settings (functions assigned to the keyfob and rules of confirmation).

The installer can remove all the APT-200 / APT-100 keyfobs and their settings by using the REM.ABAX KFBS function (SERVICE MODE ►2. HARDWARE ►1. KPDS. & EXPS. ►8. REM.ABAX KFBS).

-  and  in turn, if the user has a keyfob and you want to edit the rules of confirmation (the procedure is similar as for defining the rules of confirmation after an APT-200 / APT-100 keyfob has been added to a new user).

8. **Step 7. Editing proximity card.** Press:

- , if you want to move on to the next step,

- **1** and **# 0** in turn, if you want to add a card (the procedure is much similar to that for adding a card to a new user),
- **3_{def}** and **# 0**, if you want to remove a card.

9. **Step 8. Editing user name.** Proceed in the same way as when adding a new user.

6.10.3 Removing a user

1. Enter the user menu and press in turn **2_{abc}** **3_{def}** **# 0**.
2. Select the user who is to be removed. You can make your selection by scrolling through the list of users by means of the **X▼** and **☐▲** keys or entering the user number. Having selected the user, press **# 0**.

6.11 Canceling the telephone messaging



The telephone messaging can be cancelled together with alarm clearing, if such an option is provided by the installer.

The telephone messaging is cancelled after acknowledgement of the voice messaging (see: “Acknowledgement of voice messaging” p. 38).

Enter the user menu and press in turn **3_{def}** **# 0**.

6.12 Zone bypassing

If a zone is not to trigger alarm, you can bypass it, when the partition to which the zone belongs is disarmed. Zone bypassing is useful, for example, when you want to leave a window open when the system is armed or when a detector connected to the zone is out of order and sets off false alarms.



Zone bypassing reduces the level of protection. If a zone is bypassed while the system is armed, an intruder can exploit this vulnerability.

If a zone is bypassed because of its malfunctioning, call in the service technician immediately to repair the defect.

For security considerations, the installer may reduce the number of zones that the user will be allowed to bypass.

The zone bypassing functions can also be used to unbypass the zones (the zone inhibiting function makes it also possible to unbypass an isolated zone, while the zone isolating function makes it also possible to unbypass an inhibited zone).

6.12.1 Zone inhibiting

The inhibited zone will remain bypassed until disarming the partition it belongs to, or until unbypassing the zone by the user.



If the zone belongs to two partitions and is only armed when both partitions are armed, it will be unbypassed after disarming one of the partitions.

Enter the user menu and press in turn **4_{ghi}** **1** **# 0**. Shown in the upper line of the display will be a message to inform you that the zone is bypassed, and in the lower line – the zone name. You can scroll through the zone list using the **X▼** and **☐▲** keys. There is a symbol in the upper right corner of the display:

- – zone is not bypassed,
- ☐** – zone is inhibited,

■ – zone is isolated.

Press any number key to change the displayed symbol to one of the following symbols:

☒ – the zone is to be inhibited,
 · – the zone is to be unbypassed.

If you want to see the status of all zones which you can inhibit/unbypass, press ☀▶ or ☾◀. The numbers around the display enable identification of the zones. Use the ☀▶ and ☾◀ keys to move the cursor. To inhibit/unbypass a zone, hover the cursor over it and press any numeric key. If you want to restore the previous way of presentation of the zone list, press ☒▼ or ☐▲.

Press #☐ to quit the function. The zones will be inhibited/unbypassed.

6.12.2 Zone isolating

The isolated zone will remain bypassed until it is unbypassed by the user.

Enter the user menu and press in turn 4ghi 2abc #☐. The way of indicating the zone state and the procedure are identical to those used for inhibiting the zones, but pressing any number key will change the displayed symbol to one of the following symbols:

■ – the zone is to be isolated,
 · – the zone is to be unbypassed.

6.13 Viewing the event log

Enter the user menu and press in turn 5jkl #☐. The last event that occurred in the system will be displayed. The event description includes the time of its occurrence, its name and additional information, e.g. the partition in which the event took place, the zone which caused the event, etc. The additional information appears automatically a few seconds after the event is displayed. Press ☾◀ or ☀▶ for the additional information to be displayed sooner. To scroll through the event log, use the ☐▲ and ☒▼ keys.

i If the GRADE 2 option is enabled, two functions for viewing the events are available for the installer in the user menu:

5jkl #☐ 1 #☐ - all events saved to the control panel memory will be displayed,

5jkl #☐ 2abc #☐ - events required by the EN 50131 Standard for Grade 2 will be displayed.

6.14 Auto-arming deferment

Partition can be armed automatically by the timer on specific days at specific time. If the installer defines the time by which the auto-arming is to be deferred, you can defer the arming.

6.14.1 Simple auto-arming deferment

The installer defines whether the users will be allowed to use the simple auto-arming deferment and whether they will be able to use the simple auto-arming deferment just once or multiple times.

The simple auto-arming deferment is possible during the auto-arming delay countdown. The keypad displays then a suitable message and can additionally emit a sound signal.

Press the ☒▼ key twice to defer the auto-arming.

6.14.2 Auto-arming deferment by means of function

Enter the user menu and press in turn **6**_{mno} **1** **#** .

6.15 Setting the system time and date



Enter the user menu and press in turn **6**_{mno} **2**_{abc} **#** . The currently programmed time will be displayed. Enter a new time, and then press **#** . The date will be displayed. Enter the new date and then press **#** .

6.16 Programming the timers

You can program 4 timers. The timers can control partition arming mode and outputs. The timer compares the time with the control panel clock and executes the selected function at the preset time.



The installer defines which outputs will be controlled by the timers.

1. Enter the user menu and press in turn **6**_{mno} **3**_{def} **#** . The programming is effected by using the “step by step” method, hence the programming step number will be presented on the  and  LEDs of the first and second partitions (see: page 16, Table 1).

2. **Step 1. Selecting timer to be programmed.** Press in turn the suitable keys to select a timer:

1  **#**  - timer 1,



2_{abc}  **#**  - timer 2,



3_{def}  **#**  - timer 3,



4_{ghi}  **#**  - timer 4.



3. **Step 2. Selecting parameters to be programmed.** Press in turn the suitable keys to select a parameter:



1  **#**  - weekly schedule,

2_{abc}  **#**  - exception 1,

3_{def}  **#**  - exception 2,

4_{ghi}  **#**  - exception 3,

5_{jkl}  **#**  - exception 4,



6_{mno}  **#**  - partition 1 arming mode,

7_{pqrs}  **#**  - partition 2 arming mode.



Irrespective of the selected parameter, pressing the  key in a subsequent step will take you back to Step 2.

6.16.1 Programming the weekly schedule

1. **Step 3. Programming timer activation/deactivation time on Monday.** Use the  and  keys to move the cursor. If you want, you can only program the activation or deactivation time. Instead of the other parameter, enter the sequence 9999 then. Press **#**  to go on to the next step.

2. **Step 4. Programming timer activation/deactivation time on Tuesday.** Proceed in the same way as in Step 3.

3. **Step 5. Programming timer activation/deactivation time on Wednesday.** Proceed in the same way as in Step 3.

4. **Step 6. Programming timer activation/deactivation time on Thursday.** Proceed in the same way as in Step 3.
5. **Step 7. Programming timer activation/deactivation time on Friday.** Proceed in the same way as in Step 3.
6. **Step 8. Programming timer activation/deactivation time on Saturday.** Proceed in the same way as in Step 3.
7. **Step 9. Programming timer activation/deactivation time on Sunday.** Proceed in the same way as in Step 3.
8. **Step 10. Programming timer activation/deactivation time on every day of the week.** Proceed in the same way as in Step 3. After pressing **# 0**, you will be taken back to Step 2.

6.16.2 Programming an exception

The exception is a period when the timer will be activated/deactivated at a different time than provided for by the weekly schedule. The programming is carried out in the same way for each of the four exceptions.

1. **Step 3. Programming the date from which the exception will be valid.** Enter the year (only the two last digits), month and day. Press **# 0** to confirm the data and go on to the next step.
2. **Step 4. Programming the date to which the exception will be valid.** Proceed in the same way as in Step 3.
3. **Step 5. Programming the timer activation/deactivation time when the exception is valid.** Enter the data in the same way as for programming the timer activation/deactivation in the weekly schedule. After pressing **# 0**, you will be taken back to Step 2.

6.16.3 Selecting the arming mode



1. Define whether and what arming mode is to be activated by the timer (press one of the keys: **1** - full arming; **2_{abc}** - night arming; **3_{def}** - day arming; **4_{ghi}** - timer does not arm the partition).
2. Press **# 0**. You will be taken back to Step 2.

6.17 Programming the telephone numbers to be notified

1. Enter the user menu and press in turn **6_{mno}** **4_{ghi}** **# 0**.
2. Press in turn the suitable keys to select the telephone number to be edited (the phone numbers to which voice messaging is not enabled are only available to the installer):

- | | | |
|-------------------------|------------|----------------|
| 1 | # 0 | - telephone 1, |
| 2_{abc} | # 0 | - telephone 2, |
| 3_{def} | # 0 | - telephone 3, |
| 4_{ghi} | # 0 | - telephone 4, |
| 5_{jkl} | # 0 | - telephone 5, |
| 6_{mno} | # 0 | - telephone 6, |
| 7_{pqrs} | # 0 | - telephone 7, |
| 8_{tuv} | # 0 | - telephone 8. |

3. Enter the telephone number (the available characters are presented in Table 4). You can enter up to 16 characters. Some of the characters occupy two positions (a, b, c, d, # and *). If they are used, you can enter less characters than 16. In the upper line, on the right side of the display, you can find information on the letter case: [ABC] or [abc] (it is

displayed after you press any key and remains on the screen for a few seconds after the last keypress). Use the  and  keys to move the cursor. The  key clears the character to the left of the cursor.

4. Press  to confirm the entered number.

























Characters available after next keystroke							
key	mode [ABC]			key	mode [abc]		
	1	#			1	#	
	2	B	C		2	a	b c
	3	D	E F		3	d	
	4				4		
	5				5		
	6				6		
	7				7		
	8				8		
	9				9		
	0	*			0	*	

Table 4. Characters available in the keypad when entering telephone numbers (to change the letter case, press  key).

Special character	Function description
B	switch-over to pulse dialing
C	switch-over to tone dialing (DTMF)
D	waiting for additional signal
E	3 second pause
F	10 second pause
*	signal * in DTMF mode
#	signal # in DTMF mode
a b c d	other signals generated in DTMF mode

Table 5. Special character functions.

6.18 Programming codes to acknowledge / clear messaging

1. Enter the user menu and press in turn   .
2. Press in turn the suitable keys to select the telephone number for which the code to acknowledge / clear voice messaging is to be defined (the phone numbers to which voice messaging is not enabled are only available to the installer):

-   - telephone 1,
-   - telephone 2,
-   - telephone 3,

- 4_{ghi} # 0 - telephone 4,
5_{jkl} # 0 - telephone 5,
6_{mno} # 0 - telephone 6,
7_{pqrs} # 0 - telephone 7,
8_{tuv} # 0 - telephone 8.

3. Enter a 4-digit code, and then press # 0.

6.19 Checking the troubles / system state

When the  LED is flashing, you can check what caused this signaling. Enter the user menu and press in turn 7_{pqrs} # 0. To scroll through the list, use the X ▼ and ◀ ▶ keys.

6.19.1 Information on system state

If the GRADE 2 option is enabled by the installer, the following information will be displayed:

- partition alarms,
- alarms from zones,
- bypassed zones,
- troubles,
- partition state (disarmed or arming mode).

The higher position, the higher priority of the state.

6.19.2 Trouble handling procedure

Each trouble poses a danger to proper functioning of the alarm system and should be repaired as soon as possible. If necessary, consult the installer.



*In the event of failure of the control panel processor system (HSE), when you have exited the 7. SYSTEM STATE function by using the * 🔥 key, the “Make VERSA panel restart? 1=Yes” message will be displayed. Pressing the 1 key will restart the control panel and repair the trouble.*

6.19.3 Trouble memory and clearing the trouble memory

The installer defines whether only the current troubles are to be presented, or also those which have already ended. The flashing letter “M” in the upper right corner of the display means that the trouble has already ended.

You can clear the trouble memory after quitting the function:

1. Press * 🔥 to quit the function. The “Clear trouble memory? 1=Yes” prompt will be displayed.
2. Press 1 to clear the trouble memory (pressing another key will cancel clearing the trouble memory).



If the SERVICE MESSAGE AFTER TAMPER ALARM option is enabled in the control panel, only the installer can clear the tamper alarm memory.

6.20 Output control

Using the keypad, you can control the operation of devices connected to the outputs (e.g. to raise/lower roller blinds/shutters, turn on/off lighting or heating, etc.). The installer defines how the outputs should work (whether the output will be activated for a defined time, or it will remain active until deactivated by the user, timer, etc.).

6.20.1 Quick control of outputs

The installer can assign outputs to the numeric keys and allow them to be quickly controlled (without entering the code).

Quick activation of output

Press the key to which the controllable output is assigned, and then .





Quick deactivation of output

Press the key to which the controllable output is assigned, and then .



6.20.2 Controlling the outputs by means of proximity card **VERSA-LCDR / VERSA-KWRL2 / VERSA-LCDM-WRL**













The status of outputs can be toggled by using the proximity card, provided that the keypad has been configured by the installer so as to make this function available. In order to toggle the output status, bring the card close to the keys and hold it there for about 3 seconds.

6.20.3 Controlling the outputs by means of function

Enter the user menu and press in turn  . The output number is shown in the upper line of the display, and the output name in the lower line. You can scroll through the list of outputs by using the  and  keys. Information on the output state is shown in the upper right corner of the display:

- – output is activated,
- – output is deactivated.

Press  to activate the output, or  to deactivate the output.

If you want to see the status of all outputs you can control, press   or  . The numbers around the display enable identification of the outputs. Use the   and   keys to move the cursor. Having hovered your cursor over the output, you can activate it by pressing  or deactivate it by pressing . If you want to restore the previous way of presentation of the output list, press  or .

6.21 Tests

6.21.1 Zone test







The function enables checking the system zones and detectors connected to them for proper functioning.





You can test the zones for which the installer has programmed other wiring type than NOT USED.

Zone violation during the test will not trigger the control panel reaction, as preprogrammed for the zone.

When testing the zones, the keypad does not present the current zone state, but only indicates whether or not the zone was violated during the test.

1. Enter the user menu and press in turn   .
2. Enter two digits to define the test duration (e.g. if the time is to be 5 minutes, press in turn  and  – the test may last from 1 to 15 minutes), and then press . The keypad will indicate the zones which can be tested, using the symbol · (the numbers around the display enable identification of the zones).
3. Violate the selected zones (e.g. walking through the area supervised by the motion detector or opening the window supervised by the magnetic contact). The keypad should













inform you that the zone has been violated (the zone symbol changes to ). Information on the violation will be presented until the zone test is terminated.

- The test will be terminated automatically after the defined time has elapsed. You can terminate it earlier by pressing .

6.21.2 Output test

The function makes it possible to check proper functioning of the system outputs as well as devices connected to them.

 | *You can always test 12 outputs.*

- Enter the user menu and press in turn    . The keypad will present the state of outputs in the upper line of the display (· – output inactive;  – output active). The name of output over which the cursor is currently situated is displayed in the lower line. The  and  keys allow moving the cursor.
- Press   to activate the output, or   to deactivate the output.
- Press  to quit the function.

6.21.3 Checking the level / quality of radio / cellular signal

The function allows you to check:

- the level of signal received by the cellular antenna,
- the quality of radio signal received by the controller from MICRA (433 MHz) wireless detectors (if the VERSA-MCU controller is connected to the control panel),
- the level of radio signal received by the controller from ABAX 2 / ABAX wireless devices (if the ABAX 2 / ABAX controller is connected to the control panel).

Enter the user menu and press in turn    . In the lower line of the display, the information on signal level / quality will be shown. The upper line displays:









- the name of zone, if the level / quality of signal from a wireless device assigned to that zone is presented,
- information on the currently used SIM card, if the cellular signal level is presented.

Use the arrow keys to scroll through the list.





6.21.4 Starting the manual test transmission

Enter the user menu and press in turn    . A “Manual reporting test” event will be saved to the control panel memory. The event code will be sent to the monitoring station.







6.21.5 Telephone reporting test

Enter the user menu and press in turn     (test of telephone reporting to Station 1) or     (test of telephone reporting to Station 2). Messages with information on the currently realized operations will appear on the display. This allows problems, if any, to be diagnosed.

6.21.6 Checking the firmware version of control panel

Enter the user menu and press in turn    . Information on the control panel firmware version and build date will be displayed.

6.21.7 Checking the firmware version of modules

Enter the user menu and press in turn    . Information on the firmware of module with the lowest address will be displayed: the module name in the upper line, and the firmware version and build date in the lower line. You can scroll through the list of modules using the  and  keys. In the case of the built-in communication modules, pressing

the or key will display additional information (IP address, MAC address, individual identification number for the purpose of communication via the SATEL server [ID], individual identification number of the cellular phone [IMEI]).

6.21.8 Checking the current supply voltage in modules



Not all modules provide information on the current voltage.

Enter the user menu and press in turn . Information on supply voltage of the lowest address module will be displayed. To scroll through the list, use the arrow keys.

6.21.9 Outputs reset

Use the function to:

- deactivate 5. "DURESS" ALARM, 14. CHIME or 15. CONTROLLED function outputs (if the cut-off time equal to 0 is programmed by the installer for such an output, the output can only be deactivated in this manner),
- deactivate for 16 seconds the 11. FIRE DETECTORS POWER SUPPLY function output (to clear the alarm memory of fire detectors),
- activate the 21. DETECTORS RESETTING function output.

Enter the user menu and press in turn .

6.22 Service

The functions related to control panel programming (starting local or remote programming) are described in the PROGRAMMING manual.

6.22.1 Defining the service access rules

Enter the user menu and press in turn . In the upper line of the display, the function name will be presented, and in the lower one – the first of the available options. You can scroll through the list using the and keys. The following symbol is situated in the upper right corner of the display:

- option is enabled,
- – option is disabled.

Press any number key to enable/disable the option.

If you want to see the status of all options, press or . The numbers around the display allow the options to be identified. Use the and keys to move the cursor. To enable/disable an option, hover the cursor over it and press any numeric key. If you want to restore the previous way of presentation of the list of options, press or .

Press to confirm the changes made and quit the function.

Description of the options

The order of describing the options corresponds to their numeration in the keypad.

Permanent access – if the option is enabled, the service code can be used to get access to the alarm system at all times.







If the alarm system is to meet requirements of the EN 50131 standard for Grade 2, the service code access should be time limited.

Edit users – when the option is enabled, the person using the service code can add, edit and remove users.

Arm/Dis/Clr/Bps – when the option is enabled, the person using the service code can arm and disarm the system, clear alarms, and bypass zones (inhibit or isolate).







6.22.2 Defining the service access time

The function is available when the PERMANENT ACCESS option is disabled (see: “Defining the service access rules”).

Enter the user menu and press in turn   . The number of remaining hours will be displayed, during which the access to the alarm system is still possible by using the service code. Enter a new value from the range of 0 to 255 hours and press .

6.22.3 Replacing batteries in wireless keypad

The function is available if a wireless keypad is installed in the alarm system. The function is supported by ACU-120 / ACU-270 controller with firmware version 5.03 and ACU-220 / ACU-280 controller.

1. Enter the user menu and press in turn   .
2. Keep pressing  or  until the name of the keypad in which you want to replace the battery is displayed.
3. Press . The status of tamper switch in the keypad will not be checked for 3 minutes, which allows you to replace the battery.

7. Operating the alarm system by means of keyfob

The alarm system can be operated by means of keyfobs if to the control panel connected is:

- 433 MHz keyfobs receiver expansion module (INT-RX-S / INT-RX),
- MICRA wireless system controller (VERSA-MCU),
- ABAX 2 (ACU-220 / ACU-280) / ABAX (ACU-120 / ACU-270 / ACU-100 / ACU-250) wireless system controller.

The user can have two keyfobs:

- 433 MHz keyfob – supported by the 433 MHz keyfobs receiver expansion module or MICRA (433 MHz) wireless system controller,
- APT-200 / APT-100 bidirectional keyfob – supported by the ABAX 2 / ABAX wireless system controller.

The keyfob can start up to 6 functions. For information about functions assigned to individual buttons / button combinations, please consult the person who has configured the keyfob settings. In the case of APT-200 / APT-100 keyfob, that person should also provide information about functionality of the LEDs. The keyfob LEDs can be used to confirm execution of functions, as well as to indicate the system status (pressing a button on the APT-200 / APT-100 keyfob is accompanied by the LEDs flashing rapidly three times, and in a little while the LED(s) may come on for 3 seconds to provide information).



The installer can configure the alarm system so that the sirens connected to the system outputs can inform the user about the following events:

1 tone – starting the arming procedure (which is equivalent to arming, if the exit delay has not been programmed),

2 tones – disarming,

4 tones – alarm clearing,

7 tones – arming is not possible, or the arming procedure has failed.

Tone duration is approx. 0.3 seconds.

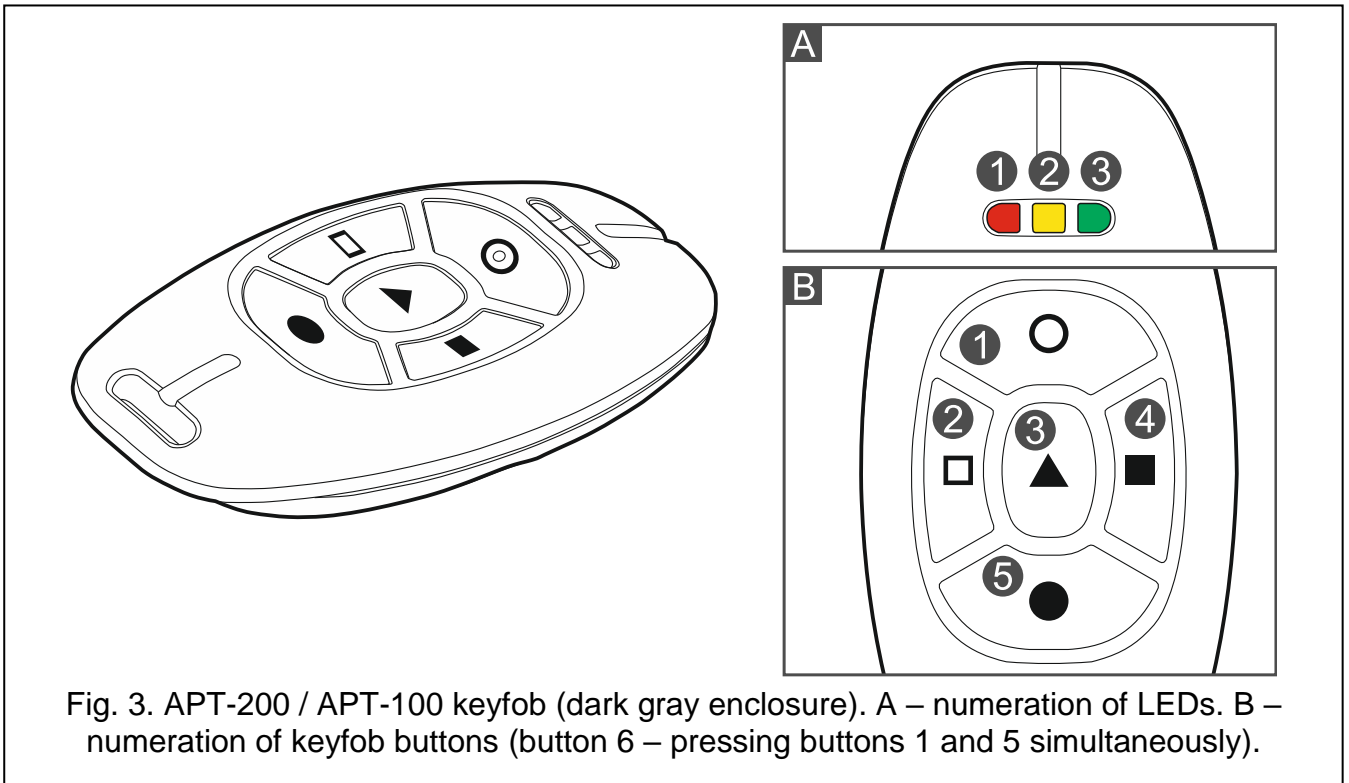

Fig. 3. APT-200 / APT-100 keyfob (dark gray enclosure). A – numeration of LEDs. B – numeration of keyfob buttons (button 6 – pressing buttons 1 and 5 simultaneously).

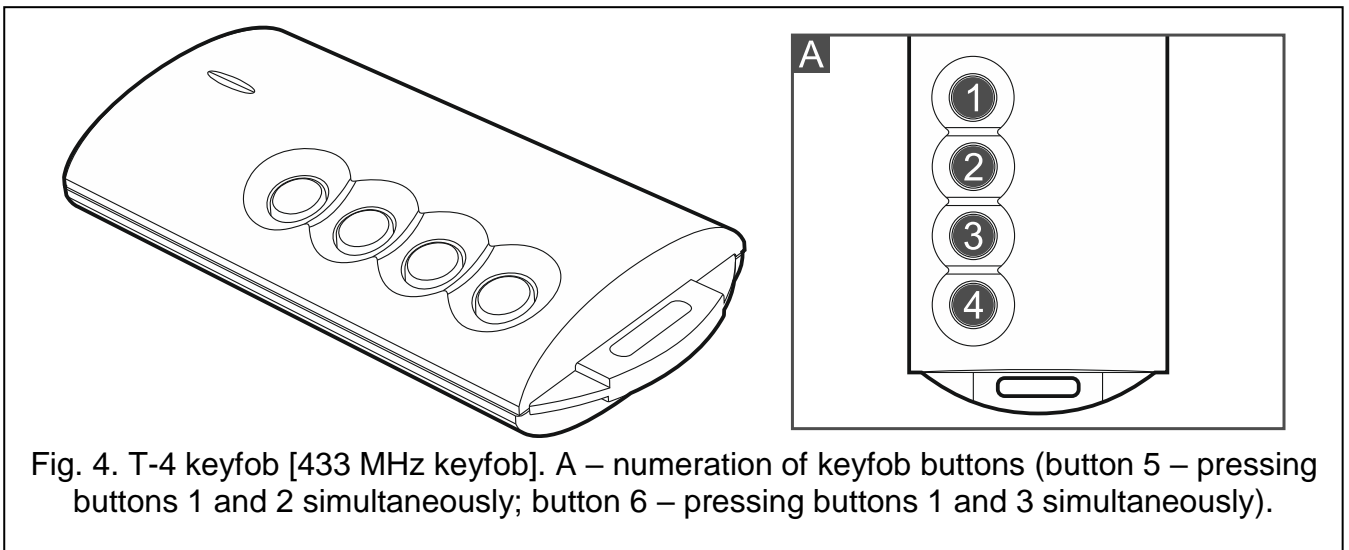

Fig. 4. T-4 keyfob [433 MHz keyfob]. A – numeration of keyfob buttons (button 5 – pressing buttons 1 and 2 simultaneously; button 6 – pressing buttons 1 and 3 simultaneously).

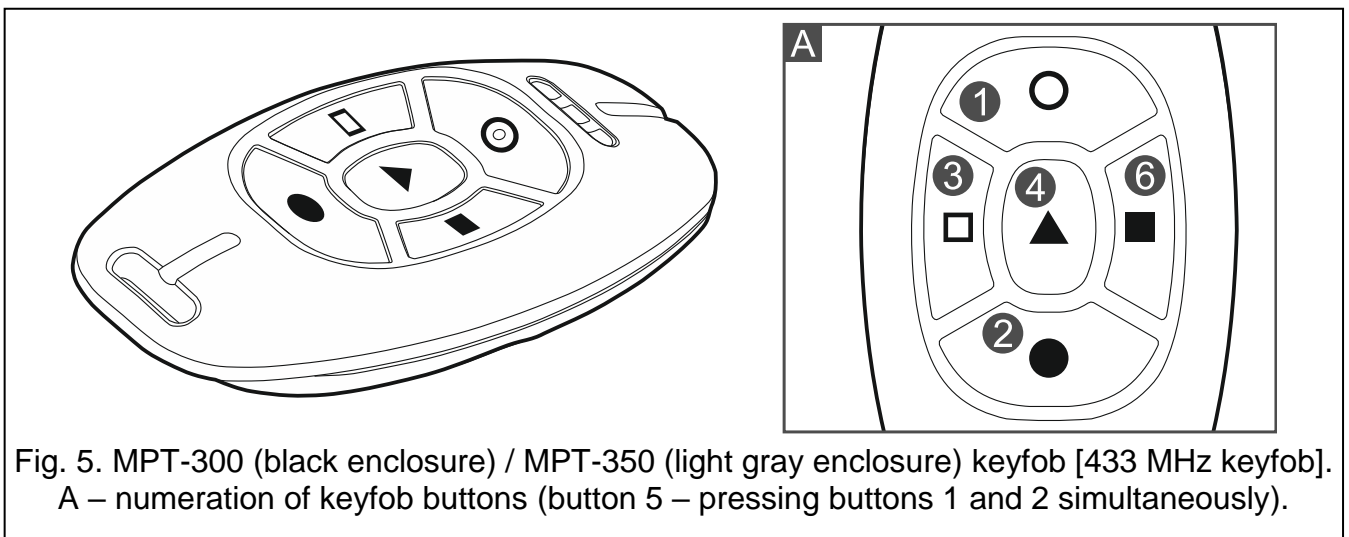

Fig. 5. MPT-300 (black enclosure) / MPT-350 (light gray enclosure) keyfob [433 MHz keyfob]. A – numeration of keyfob buttons (button 5 – pressing buttons 1 and 2 simultaneously).

7.1 Denial of arming



The information given below is not applicable, if the keyfob button controls arming zone.

The installer can program the control panel so that arming by means of keyfob is not possible when:

- in the partition to be armed, at least one zone that must not be violated during arming (the PRIORITY option has been enabled for the zone by the installer) is violated,
- in the partition to be armed, at least one alarm zone is violated beyond the exit route,
- there is trouble in the system,
- there is low battery in the keyfob.

In such a situation, to arm the system, you must either eliminate the cause that prevents arming, or force the arming.



The installer should see to it that the user is effectively notified about the denial of arming the system.

7.1.1 Forced arming

1. After an attempt to arm the system from the keyfob has failed, approach the keyfob, enter the code and press .
2. A message will appear on the display indicating why the arming has been denied. If the message includes the "1=Ok" phrase, you can press the key to force the arming.
3. Press again the keyfob button to which the arming function is assigned.



Information on the forced arming is written into the event log.

7.2 Failure of the arming procedure initiated from keyfob



The information given below is not applicable, if the keyfob button controls arming zone.

The installer can configure the alarm system in such a manner that it will not become armed, if at the moment the exit delay countdown ends:

- there is a violated zone in partition which was not violated when the arming procedure was started,
- there is a trouble which did not exist when the arming procedure was started.



The installer should see to it that the user is effectively notified of the failure of procedure to arm the system initiated from the keyfob.

8. Operating the alarm system by telephone

You can operate the alarm system by using a touch-tone (DTMF) telephone. The voice menu makes the operation an easy job. To access the voice menu, call the phone number of the control panel. Establish, in consultation with the installer, the phone number to call to get access to the voice menu.



The installer can make the option of operating the system by phone conditional on the partition state (the operation being only possible when the selected partitions are armed).

8.1 Starting the operating by telephone



The control panel can have three phone numbers: PSTN communicator number, SIM1 card number and SIM2 card number.

Two SIM cards can be installed in the control panel, but they cannot be used simultaneously by the cellular communicator. If the phone number of one of the SIM cards is not available at a given moment, call the phone number of the other card.

1. Call the control panel phone number. After the call is received, you will hear three short beeps.



The installer can configure the control panel in such a manner that the PSTN communicator will only go off hook after the recall. If this is the case, call the number, but hang up after the number of rings which has been set by the installer. Call again within three minutes. The call will be received.

2. Enter the code from the telephone keypad and confirm by pressing #. 4 short beeps followed by 1 long beep will confirm you have got access to the interactive voice menu. If your code does not authorize you to get access, you will hear three long beeps in the headset. If the code is incorrect, you will hear two long beeps in the headset.



After a wrong code is entered three times, the control panel will hang up and for the next 90 seconds it will be impossible to establish connection with the control panel.

The installer can allow for getting access to the voice menu from some defined phone numbers without the code authorization (step 2 is skipped).

3. Messages of the interactive voice menu will be played back. They will inform you which telephone keys you should use to be able to operate the control panel.

8.2 Voice menu

The structure of voice menu is shown below. Pressing the * key will always take you back to the main menu.

- 1 – macros [you can run a macro, or an installer defined sequence of actions which is to be executed by the control panel]

enter the macro number and press # (if only one macro is available, this step will be skipped)

- 1 – execute
- 7 – execute despite obstacles
- 0 – another macro
- # – next macro
- * – main menu

- 2 – partitions [you can play back information on the state of partition, arm / disarm the partition, clear alarm in the partition]

enter the partition number and press # (if only one partition is available, this step will be skipped)

- 1 – arm in full mode
- 2 – arm in night mode
- 3 – arm in day mode
- 6 – disarm
- 7 – arm despite obstacles

- 9 – clear alarms
 - 0 – another partition
 - # – next partition
 - * – main menu
- 3 – listen [if the INT-AVT terminal is connected to the control panel, you can use the listen-in function and talk to the people staying in the premises]
 - 2 – bidirectional
 - 3 – loud
 - 6 – quietly
 - * – main menu
- 4 – zones [you can play back information on the state of zone, bypass/unbypass the zone]

enter the zone number and press # (if only one zone is available, this step will be skipped)

 - 1 – inhibit
 - 2 – isolate
 - 6 – unbypass
 - 0 – another zone
 - # – next zone
 - * – main menu
- 5 – alarms [you can play back information on the alarms, clear alarms]
 - 9 – clear alarms
 - * – main menu
- 7 – troubles [you can play back information on the troubles, clear trouble memory]
 - 8 – make system restart
 - 9 – clear troubles memory
 - * – main menu
- 8 – outputs [you can play back information on the state of 15. CONTROLLED function output, activate or deactivate the output]

enter the output number and press # (if only one output is available, this step will be skipped)

 - 1 – switch on
 - 6 – switch off
 - 0 – another output
 - # – next output
 - * – main menu

8.3 Ending the operating by telephone

1. Press * key.
2. Press in turn the 0# keys. The control panel will go on-hook.



The control panel will go on hook automatically after one minute of idle state.

9. Acknowledgement of voice messaging

A special 4-digit code is used to acknowledge messaging (see: “Programming codes to acknowledge / clear messaging” p. 29). Having received voice messaging, enter the code

from the telephone keypad. The messaging acknowledgement will cancel telephone notification of the event. The installer can configure the control panel so that the user, after acknowledgement of voice messaging, should automatically get access to the interactive voice menu (see: "Operating the alarm system by telephone" p. 36).

10. SMS control

The alarm system can be operated by means of the SMS messages containing suitable control commands. The SMS message must be sent to the number of the currently used SIM card. The contents of control commands is to be programmed by the installer. Additionally, the installer defines what the control panel is to do after receiving the control command, as well as which users and from which phone numbers can operate the control panel using the SMS messages. Having received the SMS message, the control panel can perform the following operations:

- arm the system,
- disarm the system and clear alarm,
- trigger panic, fire or medical (auxiliary) alarm,
- activate / deactivate / toggle the 15. CONTROLLED output,
- send the USSD codes to the operator of SIM card installed in the control panel (e.g. to check the card account status or recharge it). The answer received from the operator is forwarded in the form of SMS message to the telephone number from which the control command was sent.

Two or more control commands can be inserted in one SMS message.

When sending the USSD codes, the SMS message must have the following form:

xxxx=yyyy=

where "xxxx" is the control command and "yyyy" is the USSD code supported by the cellular network operator.



The control panel is case sensitive.

11. VERSA CONTROL application

The VERSA CONTROL is a mobile application that allows you to remotely operate your alarm system, i.e.:

- arm / disarm the system or clear alarm,
- bypass / unbypass the zones,
- control the outputs,
- view the event log,
- view the troubles.

Additionally, the application can provide information on the alarm system events by using push notifications.

If the IP cameras are installed in the protected premises, using the application you can watch video from these cameras.

Communication between the application and the control panel is encrypted.

You can download the application from the internet stores: "Google play" (Android system devices) or "App Store" (iOS system devices).



In order to establish connection between the application and the control panel, it is required to enter the MAC address and ID of the control panel. You can check these parameters by running the EXPANDER VER. function in the keypad (see: “Checking the firmware version of modules” p. 32).

You can enter the MAC address and ID by scanning the QR code with a mobile device. You can obtain the QR code from the installer or a user who has already entered the alarm control panel data in the mobile application. Just display the QR code on the device in which the settings for communication with the given control panel are already configured and scan this QR code.

Operating the alarm system by means of the application is possible after entering the user code. Using a wrong code three times may trigger alarm.

11.1 First start of the VERSA CONTROL application (Android)

1. A prompt will be displayed asking you whether access to the application is to be password protected. You can enable password protection or not.
2. The tutorial will be displayed (Fig. 6). Tap “Skip” to skip it.

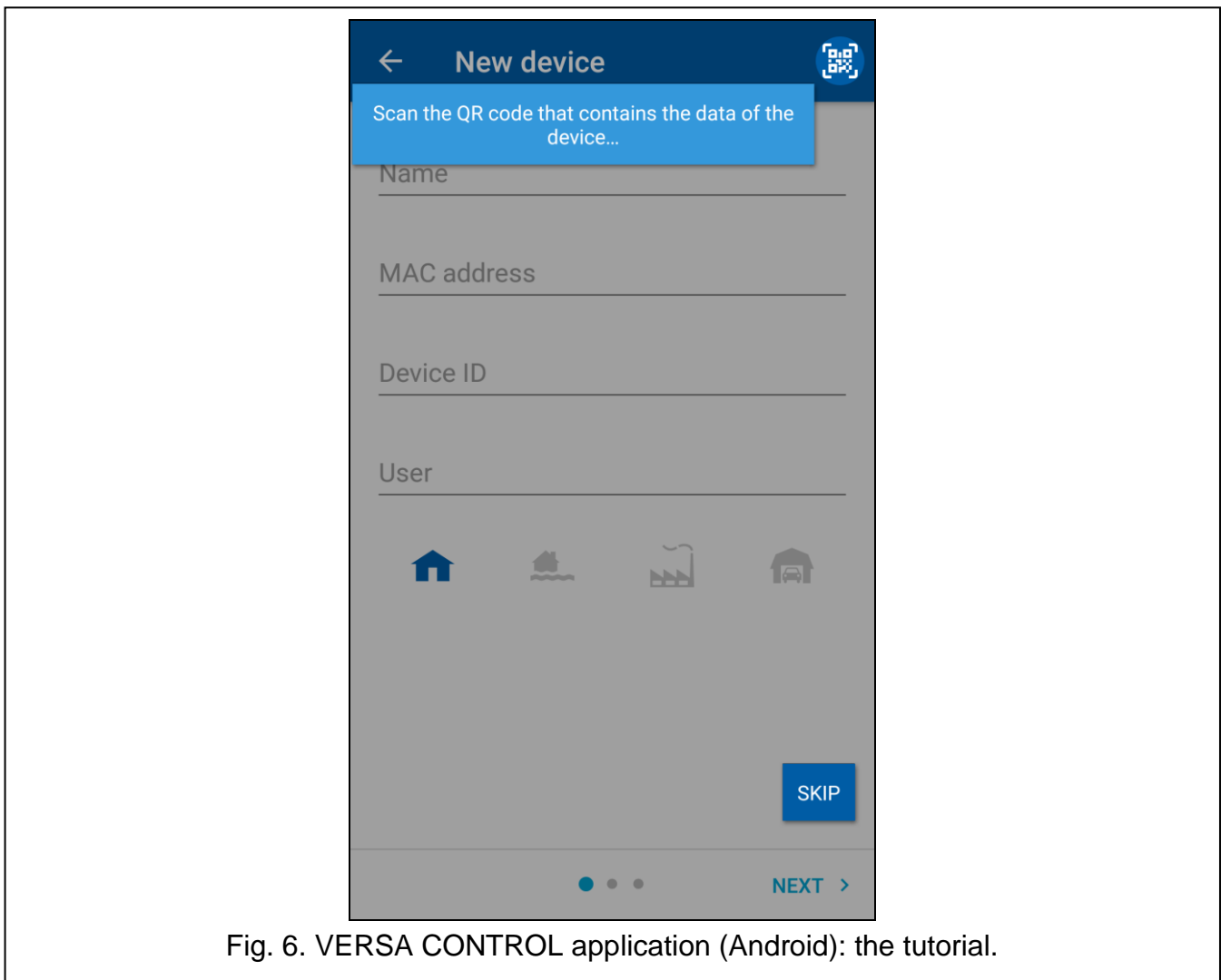

Fig. 6. VERSA CONTROL application (Android): the tutorial.

11.1.1 Adding a new alarm system by using the QR code (Android)

1. Tap .

2. Allow the application to access the camera.
3. Scan the QR code.
4. Enter the password protecting the QR code and tap “OK”. The name, MAC address and ID number of the control panel will be entered.
5. Enter your user code in the “User” field.
6. Select the icon that will be displayed next to the name on the list of alarm systems.
7. Tap „Next”.
8. Enable / disable the push notifications of the alarm system events. If you enable the push notifications, select the events about which you want to be informed.
9. If you want to watch video from IP cameras in the application, configure the camera settings. If you do not want to use the application to watch video from IP cameras, skip the tutorial and tap “Done”.

11.1.2 Adding a new alarm system without using the QR code (Android)

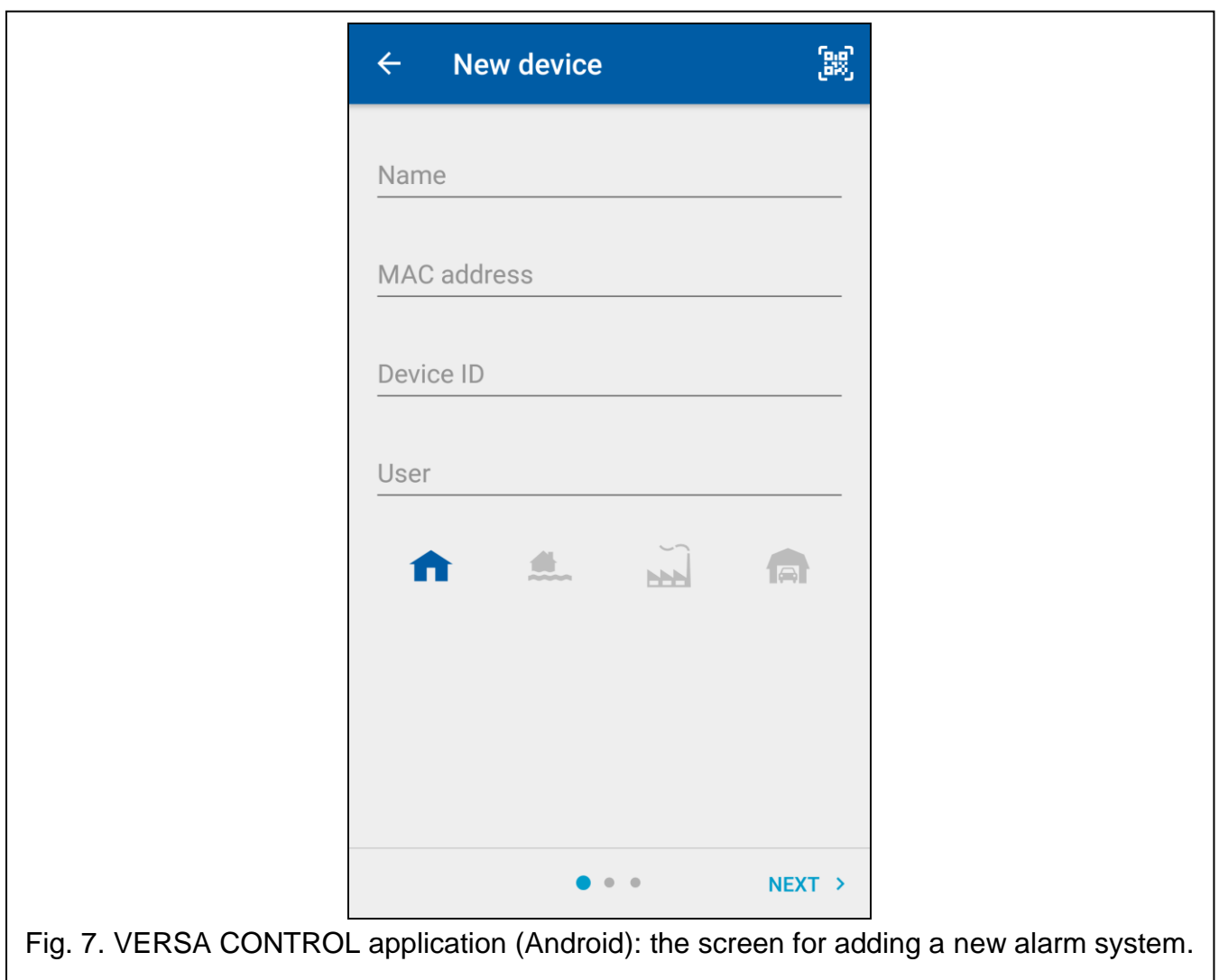

Fig. 7. VERSA CONTROL application (Android): the screen for adding a new alarm system.

1. Enter the name (it will help you to identify the alarm system while using the application).
2. Enter the MAC address of the built-in Ethernet module.
3. Enter the ID number of the control panel (the individual identification number for the purpose of communication via the SATEL server).
4. Enter your user code in the “User” field.
5. Select the icon that will be displayed next to the name on the list of alarm systems.

6. Tap „Next”.
7. Enable / disable the push notifications of the alarm system events. If you enable the push notifications, select the events about which you want to be informed.
8. If you want to watch video from IP cameras in the application, configure the camera settings. If you do not want to use the application to watch video from IP cameras, skip the tutorial and tap “Done”.

11.2 First start of the VERSA CONTROL application (iOS)

1. The application will request your permission to send notifications. You can either allow notifications or not (you can change the settings later).
2. A prompt will be displayed asking you whether access to the application is to be password protected. You can enable password protection or not.
3. The tutorial will be displayed (Fig. 8). Tap “Skip” to skip it.

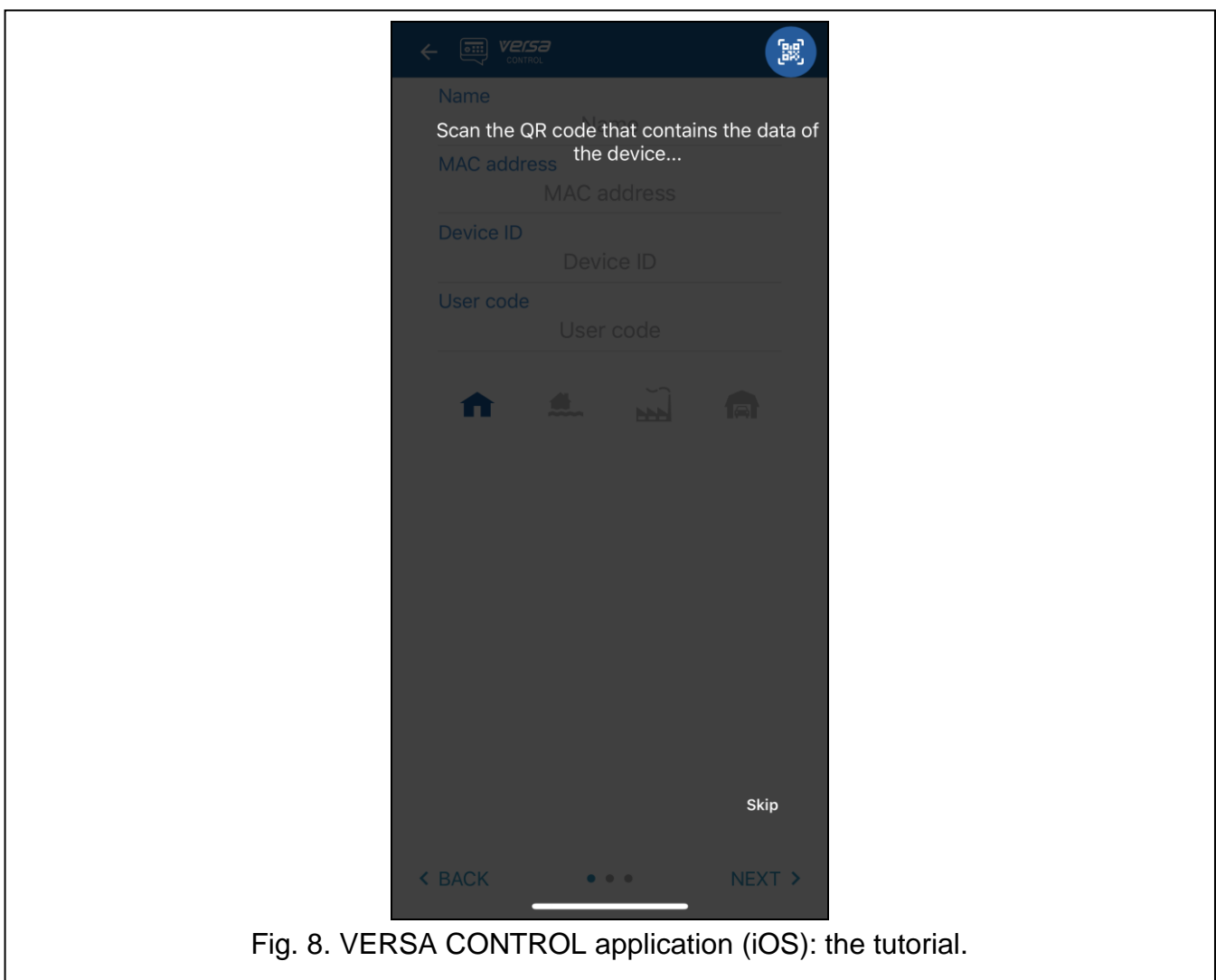

11.2.1 Adding a new alarm system by using the QR code (iOS)

1. Tap .
2. Allow the application to access the camera.
3. Scan the QR code.
4. Enter the password protecting the QR code and tap “OK”. The name, MAC address and ID number of the control panel will be entered.

5. Enter your user code.
6. Select the icon that will be displayed next to the name on the list of alarm systems.
7. Tap „Next”.
8. Enable / disable the push notifications of the alarm system events. If you enable the push notifications, select the events about which you want to be informed.
9. If you want to watch video from IP cameras in the application, configure the camera settings. If you do not want to use the application to watch video from IP cameras, skip the tutorial and tap “Done”.

11.2.2 Adding a new alarm system without using the QR code (iOS)

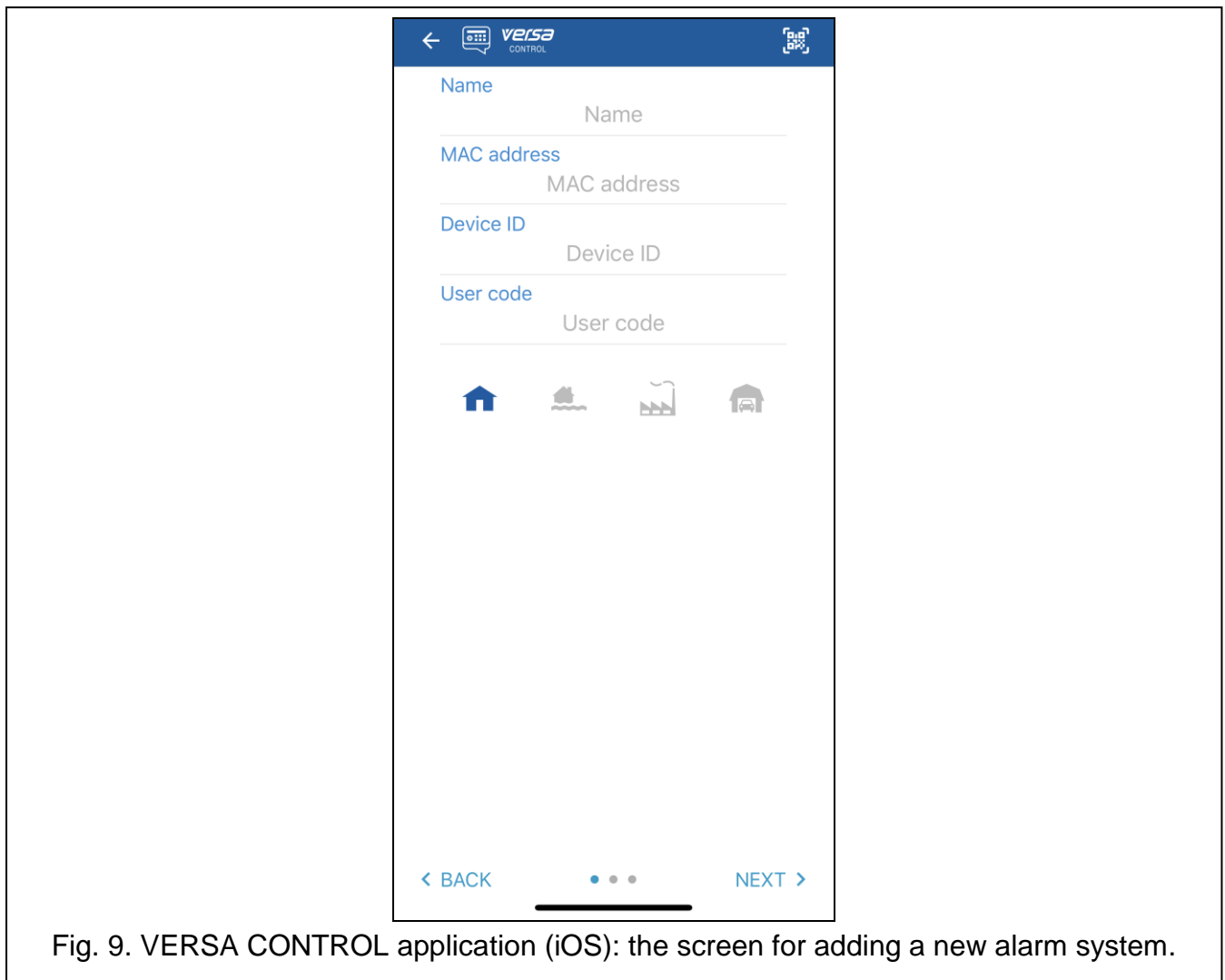

Fig. 9. VERSA CONTROL application (iOS): the screen for adding a new alarm system.

1. Enter the name (it will help you to identify the alarm system while using the application).
2. Enter the MAC address of the built-in Ethernet module.
3. Enter the ID number of the control panel (the individual identification number for the purpose of communication via the SATEL server).
4. Enter your user code.
5. Select the icon that will be displayed next to the name on the list of alarm systems.
6. Tap „Next”.
7. Enable / disable the push notifications of the alarm system events. If you enable the push notifications, select the events about which you want to be informed.

8. If you want to watch video from IP cameras in the application, configure the camera settings. If you do not want to use the application to watch video from IP cameras, skip the tutorial and tap “Done”.

12. Manual update history

Manual version	Introduced changes
09/21	<ul style="list-style-type: none">• Information on INT-TSG2 and INT-TSH2 keypads have been added.