

Alarm Control Panel

VERSA PLUS LTE

Firmware Version 1.10

Satel  [®]



INSTALLER MANUAL

EN

versa_plus_lte_i_en 09/21

SATEL sp. z o.o.
ul. Budowlanych 66 • 80-298 Gdańsk • POLAND
tel. +48 58 320 94 00
www.satel.eu

IMPORTANT

The security alarm system should be installed by qualified personnel.

Prior to installation, please read carefully this manual in order to avoid mistakes that can lead to malfunction or even damage to the equipment.

Disconnect power before making any electrical connections.

Changes, modifications or repairs not authorized by the manufacturer shall void your rights under the warranty.

SATEL aims to continually improve the quality of its products, which may result in changes in their technical specifications and software. Current information about the changes being introduced is available on our website.

Please visit us:
<https://support.satel.eu>

Hereby, SATEL sp. z o.o. declares that the radio equipment type VERSA Plus LTE is in compliance with Directive 2014/53/EU. The full text of the EU declaration of conformity is available at the following internet address: www.satel.eu/ce

The following symbols may be used in this manual:



- note,



- caution.

CONTENTS

1. Introduction	3
2. Features	3
3. Keypads	5
3.1 Keypads features	6
4. Expansion modules	7
5. System installation	7
5.1 Installation plan	7
5.2 Estimation of the system current consumption	7
5.3 Cabling	8
5.4 Installation of control panel mainboard	8
5.4.1 Description of the mainboard	9
5.5 Connecting devices to the communication bus	10
5.5.1 Connecting hardwired keypads	11
5.5.2 Connecting 433 MHz keyfobs receiver expansion module	12
5.5.3 Connecting MICRA wireless system controller	12
5.5.4 Connecting ABAX 2 / ABAX wireless system controller	13
5.5.5 Connecting the hardwired zone expanders	14
5.5.6 Connecting the hardwired output expander	16
5.5.7 Connecting proximity card arm/disarm devices	16
5.6 Connecting the detectors	17
5.6.1 End-of-line resistors	20
5.7 Connecting the sirens	20
5.8 Connecting the radio monitoring transmitter	21
5.9 Connecting the analog telephone line	22
5.10 Connecting the Ethernet network	23
5.11 Connecting the INT-AVT terminal	23
5.11.1 Mounting the INT-AVT terminal	23
5.12 Connecting the power supply and starting the control panel	25
5.12.1 Main power supply	25
5.12.2 Backup power supply	25
5.12.3 Control panel power-up / start-up procedure	25
5.12.4 Emergency procedure of the control panel start-up	26
5.12.5 First steps after starting-up the control panel	26
5.13 Programming addresses for the hardwired keypads	26
5.13.1 Programming the address by means of the service function	26
5.13.2 Programming the address without entering the service mode	27
5.14 Identification of devices connected to the bus	28
5.14.1 Starting the identification function from keypad	28
5.14.2 Starting the identification function from DLOADX program	28
5.15 Installing the SIM card	28
5.16 Connecting the computer to the control panel	29
5.17 Installation of ABAX 2 / ABAX wireless devices	29
5.17.1 Adding new ABAX 2 / ABAX wireless devices	29
5.17.2 Removing ABAX 2 / ABAX wireless devices	31
5.18 Installation of MICRA (433 MHz) wireless detectors	32
5.18.1 Adding new MICRA (433 MHz) wireless detectors	32
5.18.2 Removing MICRA (433 MHz) wireless detectors	34

- 6. Numeration of zones and outputs in the system34**
 - 6.1 Numeration of zones.....34
 - 6.1.1 Hardwired zones.....34
 - 6.1.2 Wireless zones34
 - 6.2 Numeration of outputs35
 - 6.2.1 Hardwired outputs35
 - 6.2.2 Wireless outputs35
- 7. Specifications35**
 - 7.1 Control panel35
 - 7.2 VERSA-LCD keypad.....36
 - 7.3 VERSA-LCDM keypad.....36
 - 7.4 VERSA-LCDR keypad36
 - 7.5 VERSA-LED keypad.....37
- 8. Manual update history.....37**

1. Introduction

This manual describes the VERSA Plus LTE control panel and how it should be installed. In addition, the manual provides information about devices compatible with the control panel and how they are to be connected.

The VERSA Plus LTE alarm control panel meets the requirements of the following standards: EN 50131-1 Grade 2, EN 50131-3 Grade 2, EN 50131-6 Grade 2, EN 50130-4 and EN 50130-5 Class II.

2. Features

System structure

- 2 partitions (group of zones).
- Each zone can be assigned to two partitions.

Zones

- 4 programmable hardwired zones on the control panel mainboard:
 - support for NO and NC type detectors, as well as roller shutter and shock detectors,
 - support for Single EOL and Double EOL configuration.
- Electrical protection of the zones.
- Maximum number of programmable zones: 30.
- 20 zone types.
- NC type tamper input on the control panel mainboard.

Outputs

- 5 programmable hardwired outputs on the control panel mainboard:
 - 2 high-current outputs,
 - 2 low-current outputs, OC type,
 - 1 relay output.
- Maximum number of programmable outputs: 12.
- 22 performed functions.
- Capability to operate the radio monitoring transmitter using the mainboard low-current outputs (support for PC-16 OUT format).
- 3 power supply outputs on the control panel mainboard.
- Electrical protection of the outputs.
- An output on the control panel mainboard for connecting a dedicated, enclosure mounted sounder.

Communication bus

- Capability to connect keypads and expansion modules.
- Electrical protection of communication bus.

Communication

- Built-in communicators:
 - PSTN,
 - cellular (LTE module designed for use in the 2G, 3G and 4G cellular networks),
 - Ethernet.

- Dual SIM (nano-SIM) support by cellular communicator.
- Built-in 300 bps modem.

Reporting

- Reporting events to two monitoring stations:
 - several communication formats (including Contact ID and SIA),
 - 4 identifiers.
- Multiple transmission paths:
 - Ethernet network,
 - GPRS/LTE (LTE/HSPA+/EDGE/GPRS data transmission),
 - GSM voice channel,
 - SMS messages,
 - analog telephone network.
- Defining priority for various event reporting paths.

Messaging

- Event messaging to 8 phone numbers in the form of:
 - 16 voice messages,
 - 64 text messages (with installer defined content).
- Sending event notifications to 8 e-mail addresses using e-mail messages (with automatically generated content).
- Sending event notifications to 8 telephone numbers using SMS messages (with automatically generated content).
- Informing users of the VERSA CONTROL application about events using push notifications.

Built-in voice module

- Nearly 13 minutes for messages to be used in the voice menu.
- More than 4 minutes for 16 messages for telephone notification (the message may take up to 16 seconds).

Remote operation using a telephone

- Checking the alarm system status (DTMF).
- Control of the alarm system (DTMF or SMS).
- Capability to define macrocommands to run a number of different functions, thus facilitating remote control via telephone.
- Voice menu to make operation easier (DTMF).

VERSA CONTROL mobile application

- Operating the alarm system from mobile devices:
 - control of the alarm system,
 - checking the alarm system status.

Acoustic alarm verification

- Two-way audio verification of the alarm (listen-in / talk).
- Support for INT-AVT terminal (version made after 1 December 2014).

Event log

- 2047 events.

Users

- 30 users.
- Capability to assign to the user:
 - a code,
 - a proximity card (125 kHz passive transponder, which may be in the form of a card, tag, etc.),
 - keyfob.
- Authority level determining the scope of access to the system.

Timers

- 4 timers to automatically:
 - arm/disarm the partitions,
 - control the outputs (switching the lights on/off, watering the garden, etc.).

Programming

- Local programming:
 - keypad,
 - computer with the DLOADX program installed, connected to the control panel USB port (configuring the alarm system),
 - computer with the VG-SOFT program installed, connected to the control panel USB port (configuring the built in voice module).
- Remote programming using a computer with DLOADX program installed, via:
 - PSTN telephone network (modem),
 - cellular network (modem / LTE/HSPA+/EDGE/GPRS data transmission),
 - Ethernet network.

Built-in power supply

- Switching-mode power supply 12 V / 2 A.
- Short-circuit protection.
- Battery charging system.
- Battery status monitoring and low battery cut-off circuit.

Mainboard

- USB MINI-B socket to allow:
 - local programming by means of a computer with the DLOADX / VG-SOFT program installed
 - firmware update for the control panel and built-in modules.
- Removable terminals.

3. Keypads

SATEL offers the following keypads for VERSA Plus LTE alarm control panels:

INT-TSG – hardwired touchscreen keypad,

INT-TSG2 – hardwired touchscreen keypad,

INT-TSH – hardwired touchscreen keypad,

INT-TSH2 – hardwired touchscreen keypad,

VERSA-LCD – hardwired LCD keypad with mechanical keys,

VERSA-LCDM – hardwired LCD keypad with mechanical keys,

VERSA-LCDR – hardwired LCD keypad with mechanical keys and built-in proximity card reader,

VERSA-KWRL2 – wireless LCD keypad with mechanical keys and built-in proximity card reader (connection of the ACU-220 / ACU-280 / ACU-120 / ACU-270 controller required),

VERSA-LCDM-WRL – wireless LCD keypad with mechanical keys and built-in proximity card reader (connection of the ACU-120 / ACU 270 controller required),

VERSA-LED – hardwired LED keypad with mechanical keys.

The keypads are also available with different color options for display and backlight of keys. The color variant is indicated by the additional designation in the keypad name (e.g. VERSA-LCD-GR – green display and keys backlight; VERSA-LCDM-WH – white display and keys backlight).



For information on the INT-TSG, INT-TSG2, INT-TSH, INT-TSH2, VERSA-KWRL2 and VERSA-LCDM-WRL keypads, please refer to the manuals delivered with the keypads.

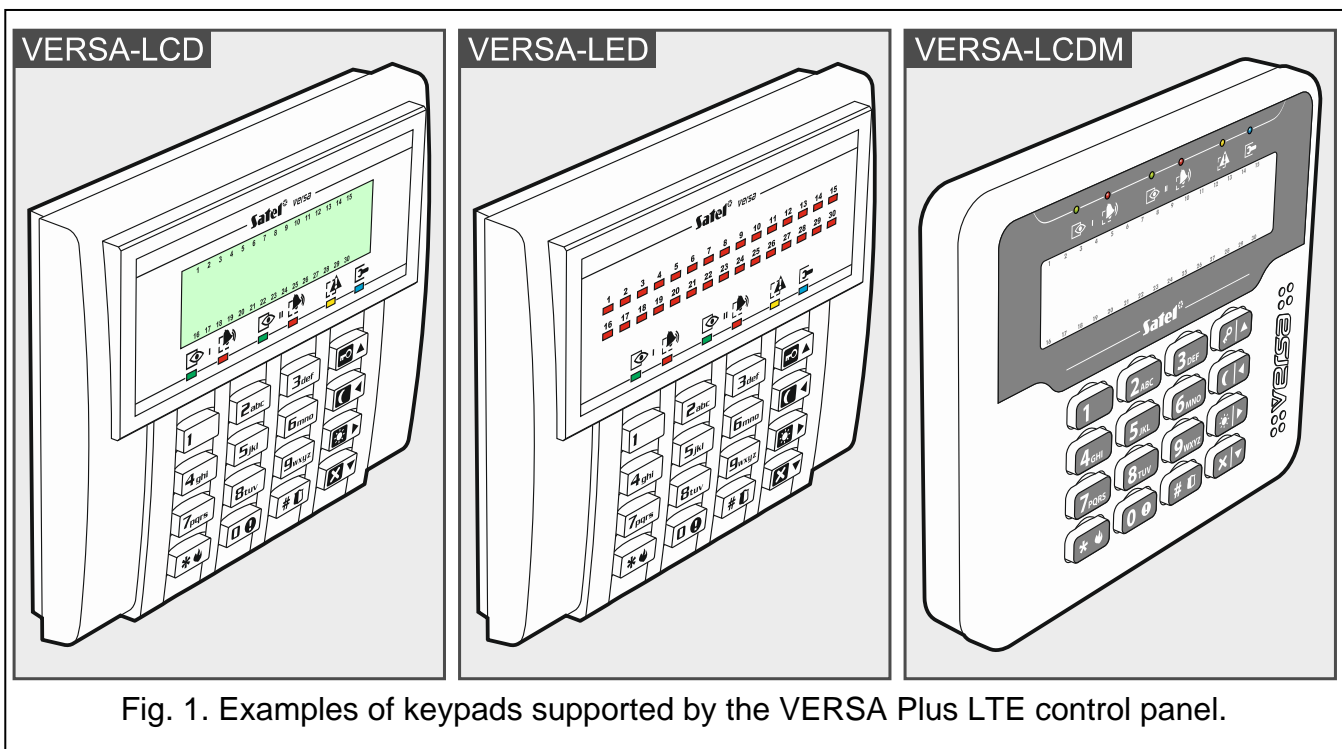

Fig. 1. Examples of keypads supported by the VERSA Plus LTE control panel.

3.1 Keypads features

- Display 2 x 16 characters with backlight. **VERSA-LCD / VERSA-LCDM / VERSA-LCDR**
- LEDs indicating the status of the zones. **VERSA-LED**
- LEDs indicating the status of the partitions and the system.
- 12 keys, bearing designations according to telephone standard and intended for entering data.
- 4 additional keys for menu navigation and arming/disarming.
- Backlit keys.

- Built-in proximity card reader. **VERSA-LCDR**
- Tamper contact reacting to the enclosure opening or detaching from the wall.

4. Expansion modules

INT-RX-S / INT-RX. 433 MHz keyfobs receiver expansion module. Enables operation of the alarm system using the 433 MHz keyfobs.

VERSA-MCU. MICRA wireless system controller. Enables the alarm system to be operated using the 433 MHz keyfobs and the MICRA (433 MHz) wireless detectors to be used in the alarm system.

ACU-220 / ACU-280. ABAX 2 wireless system controller. Enables the alarm system to be operated using the ABAX 2 keyfobs and the ABAX 2 bidirectional wireless devices to be used in the alarm system.

ACU-120 / ACU-270 / ACU-100 / ACU-250. ABAX wireless system controller. Enables the alarm system to be operated using the ABAX 2 / ABAX keyfobs and the ABAX 2 / ABAX bidirectional wireless devices to be used in the alarm system.

INT-E / CA-64 E / CA-64 EPS. Zone expander. Adds 8 programmable hardwired zones to the security system.

INT-O / INT-ORS / CA-64 O / CA-64 OPS. Output expander. Adds 8 programmable hardwired outputs to the security system.

INT-CR / INT-IT-2 / INT-IT. Proximity card arm/disarm device. Enables arming / disarming and alarm clearing in partitions by means of proximity cards, proximity tags and other passive transponders.

5. System installation



Disconnect power before making any electrical connections.

The following tools will be useful during installation:

- blade screwdriver 2.5 mm,
- Phillips screwdriver,
- precision pliers,
- flat nose pliers,
- drill with a set of drill bits.

5.1 Installation plan

The installation must be preceded by preparation of a plan of the security alarm system. It is advisable to draw up a sketch of the premises and mark on it all the devices that are to be included in the alarm system: control panel, keypads, detectors, sirens, expansion modules etc. Thick walls, metal partitions, etc. decrease the range of cellular signal. Keep this in mind when choosing the installation place for control panel. The control panel and other alarm system components should be installed within the protected area.

5.2 Estimation of the system current consumption

At the security system planning stage you should sum up the currents consumed by all devices included in the system (control panel mainboard, keypads, additional modules, detectors, sirens, etc.). The calculation should take into account the battery charging current.

If the sum of currents exceeds the maximum output current of the control panel power supply, expander with power supply or an additional power supply unit should be used.

The sum of currents consumed by the devices connected to the power supply unit (expander with power supply) must not exceed the power supply output current.

If you plan to connect devices to particular power outputs (of the control panel, expander with power supply, etc.), remember that the sum of currents consumed by these devices must not exceed the maximum current carrying capacity of those outputs.

5.3 Cabling

It is recommended that an unshielded non-twisted cable be used for making electric connections between devices included in the system.



If you use the twisted-pair type of cable, remember that CLK (clock) and DTA (data) signals must not be sent through one pair of twisted conductors.

Select cross-section of the power supply wires so that the supply voltage drop between the power supply and the supplied device should not exceed 1 V as against the output voltage.

In order to guarantee correct functioning of the system components it is important that resistance and capacitance of the signal wires be as low as possible. When the distances between the devices are greater, several wires connected in parallel may have to be used for each signal, in order to reduce conductor resistance. This, however, may lead in consequence to an increase in conductor capacitance. Too high resistance or capacitance of the cables connecting the control panel to keypads or expansion modules can prevent the devices from working correctly (e.g. the control panel will be unable to identify devices, absence of devices will be reported, etc.). When selecting the length of cables, follow recommendations set out in sections on connection of particular types of devices.

Avoid running the cables in parallel to or in close vicinity of the 230 VAC wires, as this may result in malfunctioning of the system.

5.4 Installation of control panel mainboard



The control panel mainboard contains electronic components sensitive to electric charges.

Before connecting the mainboard to power supply source (battery, alternating voltage from transformer), you must first complete all the installation work with hardwired devices (connection of keypads, expansion modules, detectors etc.).

The control panel should be installed indoors, in spaces with normal humidity of air. The control panel must be protected against unauthorized access. The installer should provide protection for the users and service personnel by using a suitable device enclosure.

A 230 VAC power supply circuit with protective grounding must be available at the control panel installation place.

5.4.1 Description of the mainboard

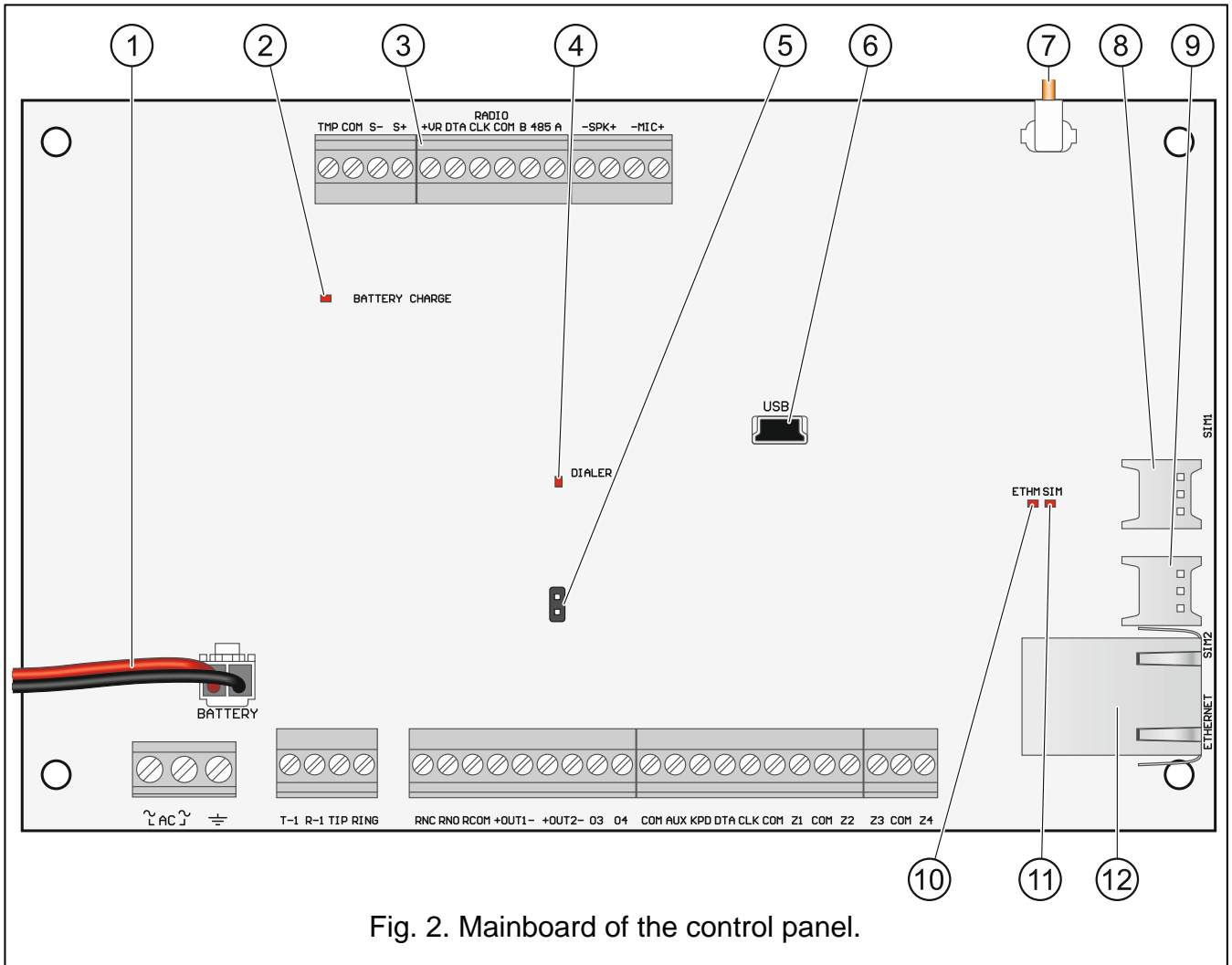

Fig. 2. Mainboard of the control panel.

- ① battery connection cables (red +, black -).
- ② BATTERY CHARGE LED. Indicates that the battery is charging.
- ③ a group of dedicated terminals for connecting the ABAX 2 (ACU-220 / ACU-280) / ABAX (ACU-120 / ACU-270 / ACU-100 / ACU-250) / MICRA (VERSA-MCU) wireless system controller.
- ④ DIALER LED. Indicates the status of control panel telephone communicator.
- ⑤ pins for emergency starting the control panel (see: “Emergency procedure of the control panel start-up” p. 26).
- ⑥ USB MINI-B socket.
- ⑦ cable terminated with a connector for antenna (the antenna is delivered with the control panel).
- ⑧ SIM1 slot in which the first SIM card is to be installed.
- ⑨ SIM2 slot in which the second SIM card is to be installed.



Inserting the SIM card into its slot before programming the card PIN code in the control panel is not recommended.

- ⑩ **ETHM LED:**
 OFF – Ethernet communicator is disabled,
 ON – Ethernet communicator is enabled.
- ⑪ **SIM LED:**
 OFF – cellular communicator is disabled,
 single flash – cellular communicator is enabled, SIM 1 card is active,
 double flash – cellular communicator is enabled, SIM 2 card is active.
- ⑫ **RJ-45 connector for Ethernet network.** It is provided with two LEDs:
 green – ON when the control panel is connected to the network,
 yellow – flashes during data transmission.

Description of terminals

AC	- power input (18 VAC).
	- protective terminal of telephone communicator (to be connected only to the PE protective earth circuit of 230 VAC mains).
T-1, R-1	- telephone line output (to premise telephones).
TIP, RING	- telephone line input (from telephone provider).
RNC	- normally closed contact of the programmable relay output (output 5).
RNO	- normally open contact of the programmable relay output (output 5).
RCOM	- common contact of the programmable relay output (output 5).
+OUT1-, +OUT2-	- programmable high-current outputs. +12 VDC voltage is always present at the “+” terminal. The “-” terminal is either shorted to or disconnected from the common ground, depending on the output status (active/inactive) and polarity.
O3, O4	- programmable low-current outputs, OC type.
COM	- common ground.
AUX	- +12 VDC power output.
KPD	- +12 VDC power output.
DTA	- communication bus data.
CLK	- communication bus clock.
Z1...Z4	- zones.
TMP	- tamper input (NC) – if not used, it should be shorted to the common ground. The TMP input has number 31 in the system.
S-, S+	- terminals for connecting sounder installed in the enclosure (sounder is included in the control panel delivery set).
+VR	- dedicated +12 VDC power output for supply of the ABAX 2 (ACU-220 / ACU-280) / ABAX (ACU-120 / ACU-270 / ACU-100 / ACU-250) / MICRA (VERSA-MCU) controller.
B 485 A	- terminals intended for future applications (RS-485).
-SPK+	- terminals for connecting the INT-AVT terminal speaker.
-MIC+	- terminals for connecting the INT-AVT terminal microphone.

5.5 Connecting devices to the communication bus



The bus wires must be run in one cable.

The total length of the expander bus may not exceed 600 m.

The device can be powered directly from the control panel, if the distance to the control panel does not exceed 300 m. Where the distance is greater, another power source must be provided for the device (power supply or expander with power supply).

The Table 1 shows the number of wires required for correct connection of the device to the expander bus if conductors with 0.5 mm diameter are used.

	CLK	DTA	COM
Distance	Number of wires		
up to 300 m	1	1	1
300-600 m	2	2	2

Table 1.

For most devices to be connected to the communication bus, setting of a suitable address is required. Two devices must not share the same address (otherwise their identification will be impossible). For information on the requirements related to address setting, please refer to the sections describing how specific devices are to be connected.

5.5.1 Connecting hardwired keypads



To meet the EN 50131 standard requirements for Grade 2:

- the VERSA-LCD / VERSA-LED keypads must have the firmware version 1.01 or newer,*
- at least one LCD keypad must be connected to the control panel.*

This will allow the users to be informed about the system state, as required by the standard.

The control panel supports up to 6 wired and wireless keypads. Addresses of the keypads must be set within a range from 0 to 5. Description of programming keypad addresses – see p. 26.

Mounting the keypad

The keypads are designed for indoor installation. The place of installation should be readily accessible to the system users.

1. Open the keypad enclosure.
2. Put the enclosure base on the wall and mark the location of mounting holes.
3. Drill the holes for wall plugs (screw anchors).
4. Run wires through the opening in the enclosure base.
5. Using wall plugs (screw anchors) and screws, fasten the enclosure base to the wall. Proper wall plugs must be selected for the type of mounting surface (different for concrete or brick wall, different for plaster wall, etc.).
6. Connect the keypad terminals to the corresponding terminals of the control panel (see: Fig. 3).
7. Close the keypad enclosure.

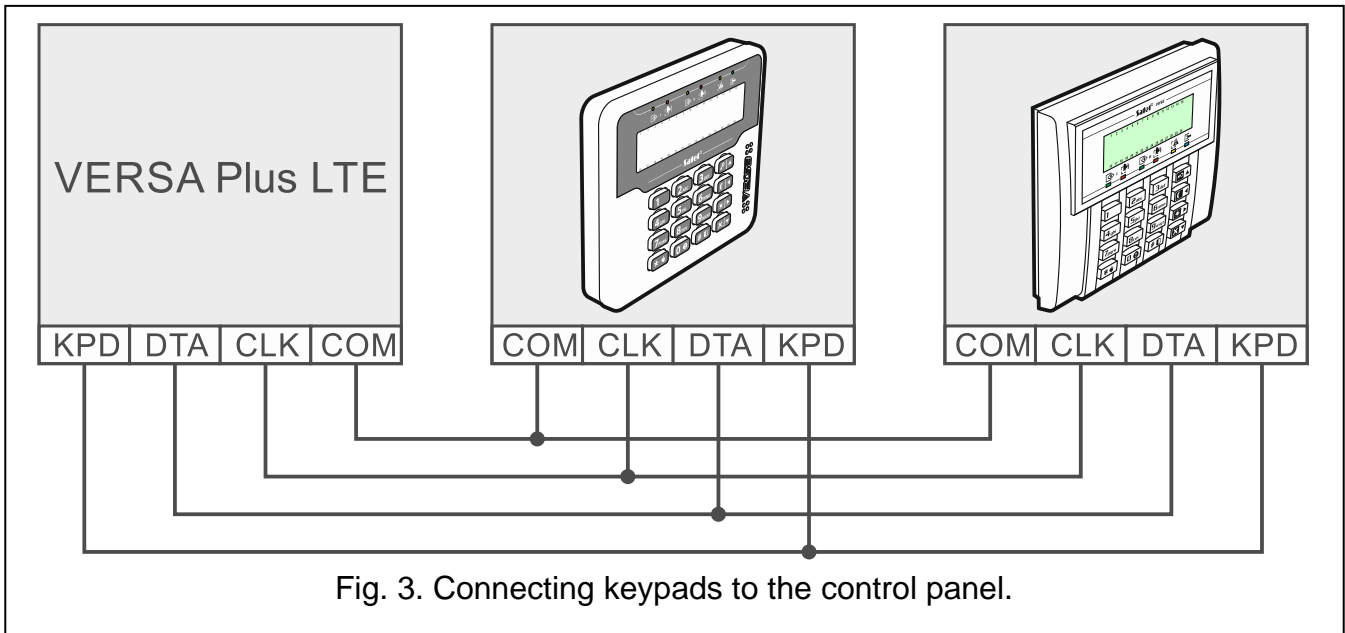

5.5.2 Connecting 433 MHz keyfobs receiver expansion module

One INT-RX-S or INT-RX expansion module can be connected to the control panel. The module enables 433 MHz keyfobs to be assigned to the users (up to 30 keyfobs). Address 7 (07h) must be set in the module.

i If the INT-RX / INT-RX-S expansion module is connected to the control panel, installation of the VERSA-MCU controller in the system is impossible.

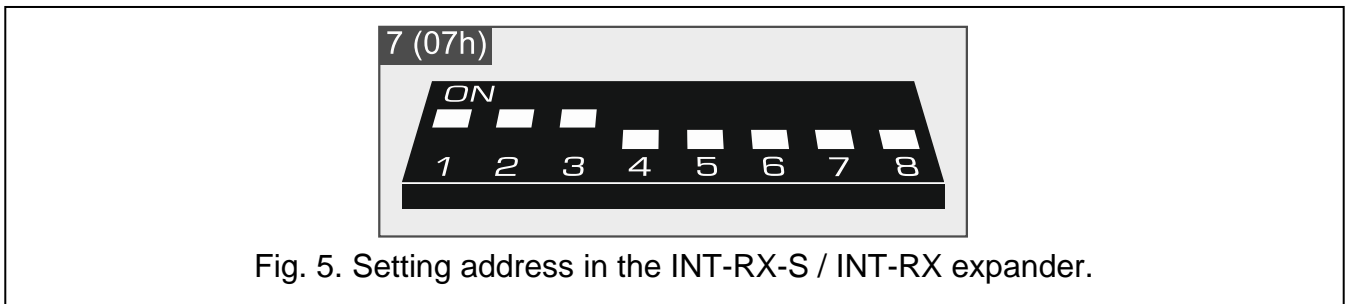
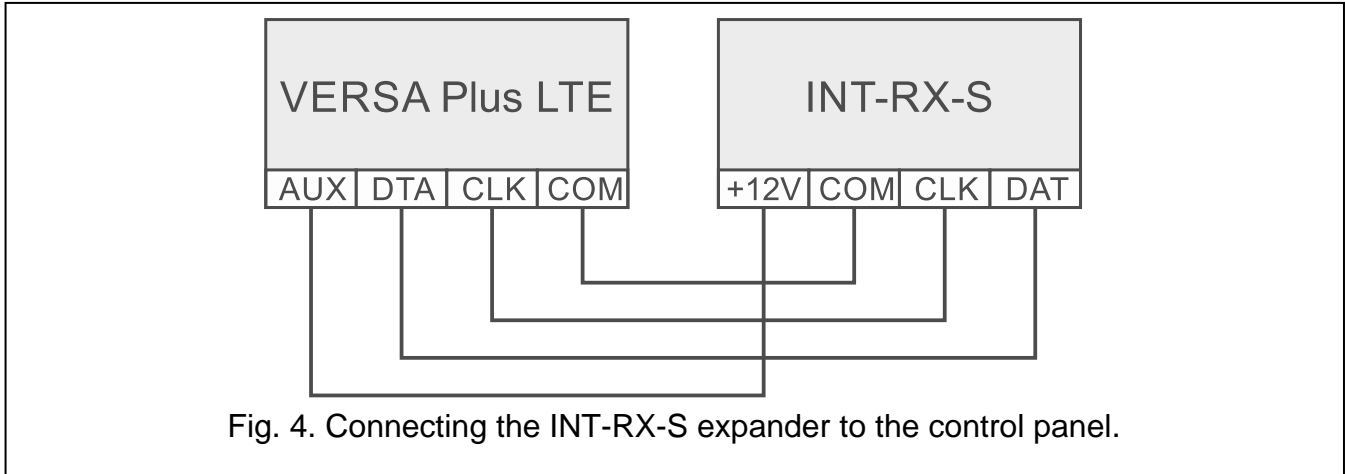

5.5.3 Connecting MICRA wireless system controller

One VERSA-MCU controller can be connected to the control panel. The controller enables 433 MHz keyfobs to be assigned to the users (up to 30 keyfobs). It also enables up to 30 MICRA (433MHz) wireless detectors to be installed in the alarm system – the control panel

can support up to 30 wireless zones. If the wireless zone number coincides with that of the wired zone (on mainboard or in expander), the wireless zone is supported. The controller DIP-switches are not used.



The VERSA-MCU controller is identified by the control panel as two devices: INT-RX (address 7) and VERSA-MCU (address 8).

If the VERSA-MCU controller is connected to the control panel, installation of the INT-RX-S / INT-RX expansion module and the ABAX 2 (ACU-220 / ACU-280) / ABAX (ACU-120 / ACU-270 / ACU-100 / ACU-250) controller in the system is impossible.

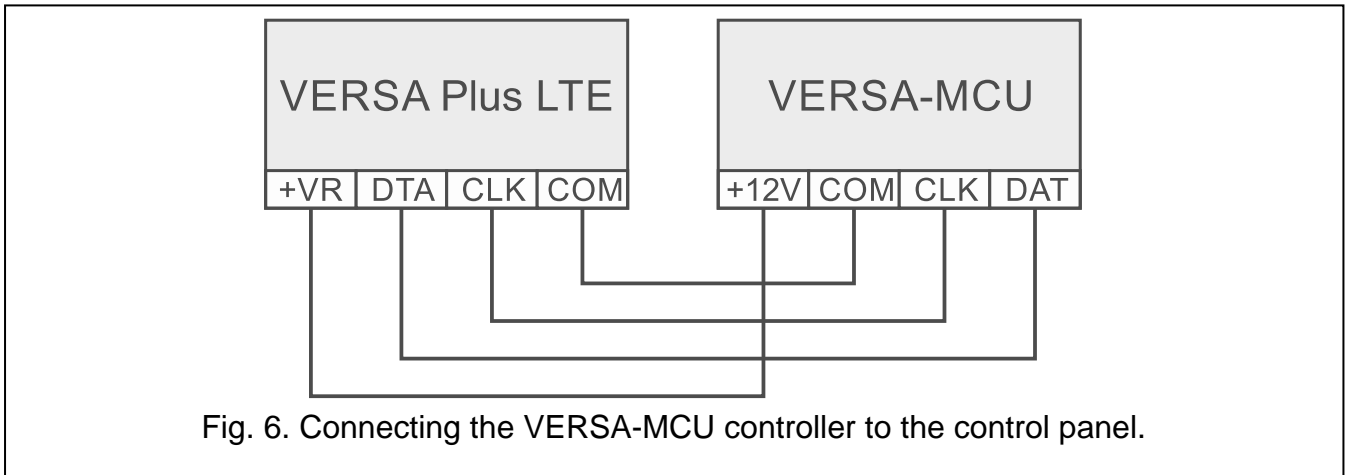

Fig. 6. Connecting the VERSA-MCU controller to the control panel.

5.5.4 Connecting ABAX 2 / ABAX wireless system controller

One ABAX 2 (ACU-220 / ACU-280) / ABAX (ACU-120 / ACU-270 / ACU-100 / ACU-250) controller can be connected to the control panel. The controller enables ABAX 2 / ABAX keyfobs to be assigned to the users (up to 30 keyfobs). It also enables up to 30 ABAX 2 / ABAX wireless devices to be installed in the alarm system – the control panel can support up to 30 wireless zones and 12 wireless outputs. If the wireless zone number coincides with that of the wired zone (on mainboard or in expander), the wireless zone is supported. If the ACU-220 / ACU-280 / ACU-120 / ACU-270 controller is connected to the control panel, you can install the wireless keypads in the system.

Depending on the controller, set the DIP-switches as required:

ACU-220 / ACU-280: switch 9 to OFF position, switch 10 to ON position, and the other switches freely (in the ACU-220 controller you can select the transmitting antenna using the switch 8),

ACU-120 / ACU-270: switch 8 to ON position, the status of the other switches being irrelevant,

ACU-100: switches 4, 7 and 8 to ON position, and the other ones to OFF position (address 8 (08h) and the VERSA control panels compatibility mode enabled),

ACU-250: switch 4 to ON position, and the other ones to OFF position (address 8 (08h)).



All controllers of the ABAX 2 / ABAX wireless system are identified by the control panel as the ACU-100 controller.

If the ABAX 2 (ACU-220 / ACU-280) / ABAX (ACU-120 / ACU-270 / ACU-100 / ACU-250) controller is connected to the control panel, installation of the VERSA-MCU controller in the system is impossible.

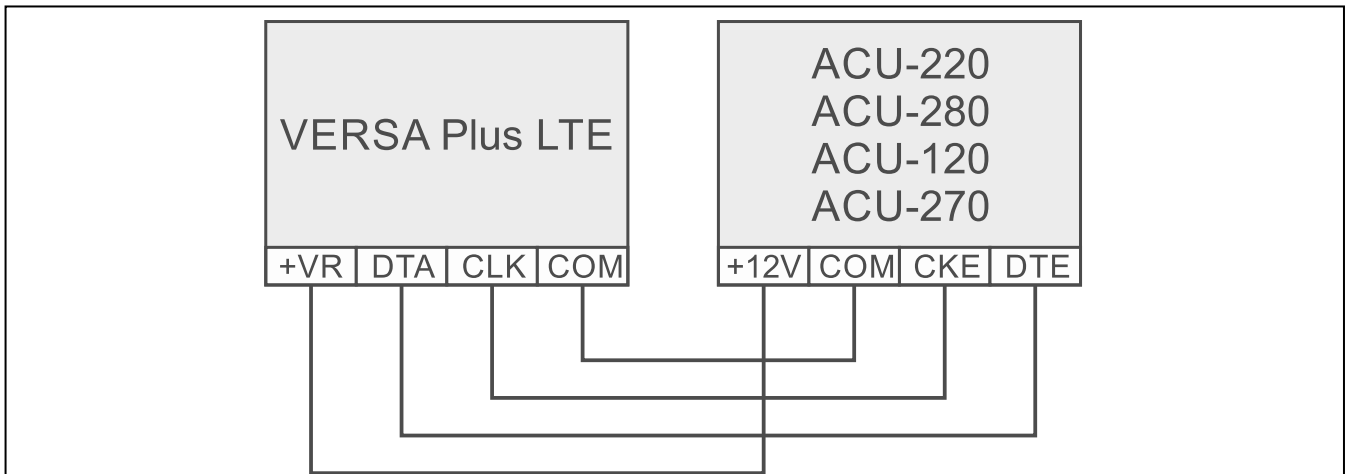

Fig. 7. Connecting the ACU-220 / ACU-280 / ACU-120 / ACU-270 controller to the control panel.

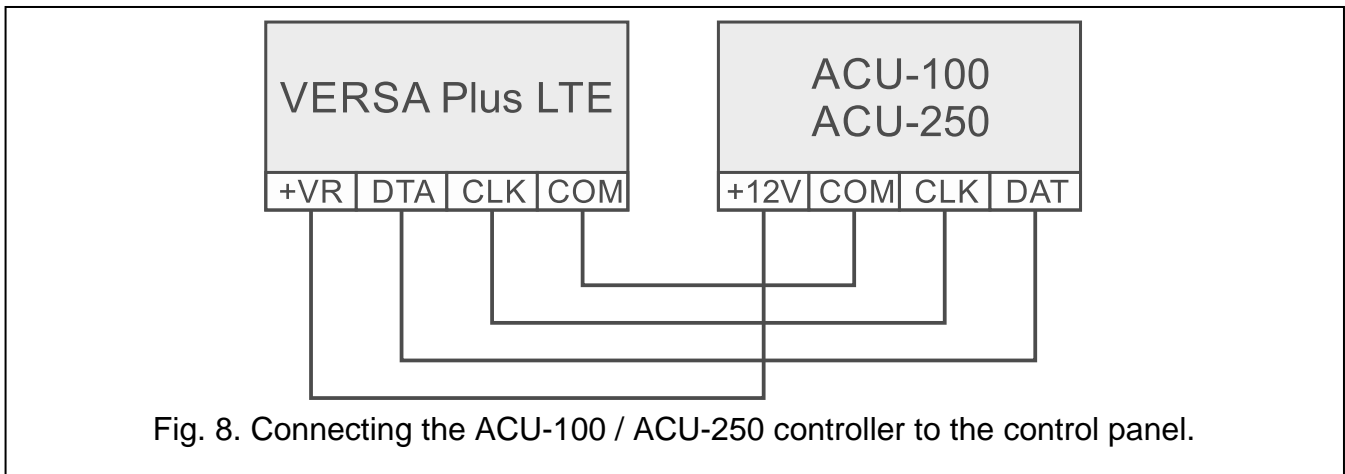

Fig. 8. Connecting the ACU-100 / ACU-250 controller to the control panel.

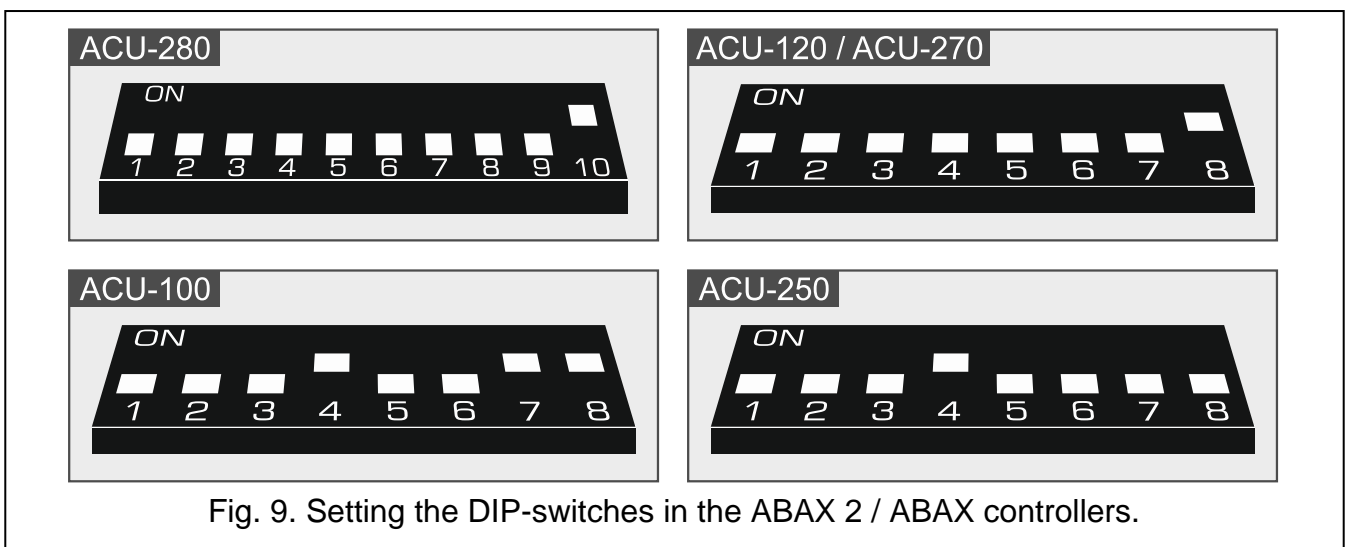

Fig. 9. Setting the DIP-switches in the ABAX 2 / ABAX controllers.

5.5.5 Connecting the hardwired zone expanders

Up to three INT-E / CA-64 E / CA-64 EPS expanders can be connected to the control panel. This enables expansion of the system by adding up to 24 programmable wired zones. Using the expander DIP-switches:

- set an address within the range from 12 (0Ch) to 14 (0Eh) – switches 1-5,

- define how the expander is to be identified – switch 10 (INT-E) or 8 (CA-64 E / CA-64 EPS).

For detailed information on how the expander will be identified and what are the functional differences resulting from the identification, please refer to the manual delivered with the expander.

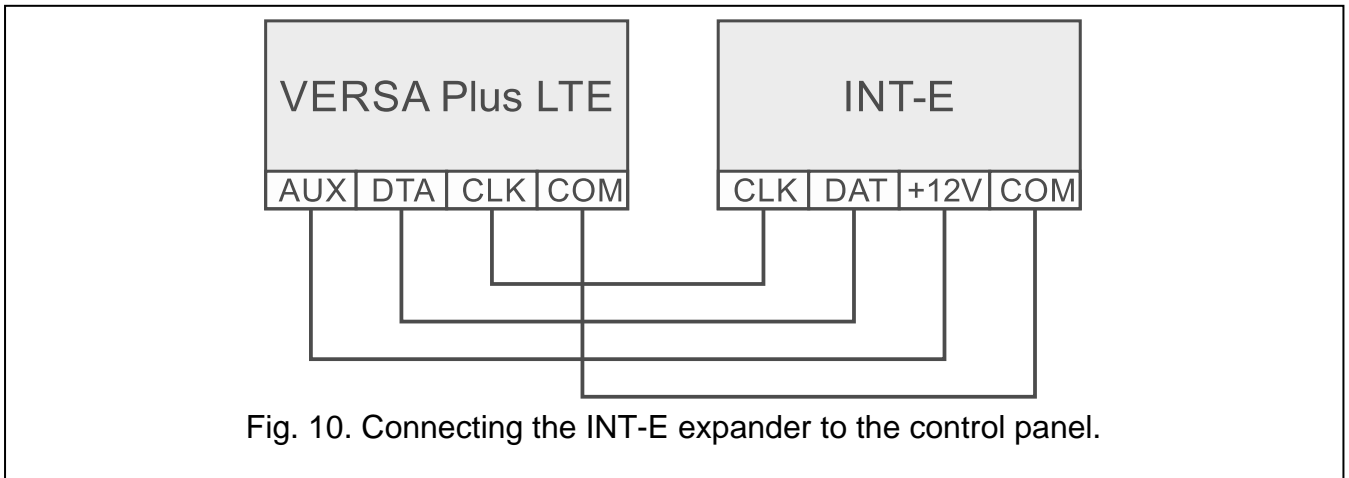

Fig. 10. Connecting the INT-E expander to the control panel.

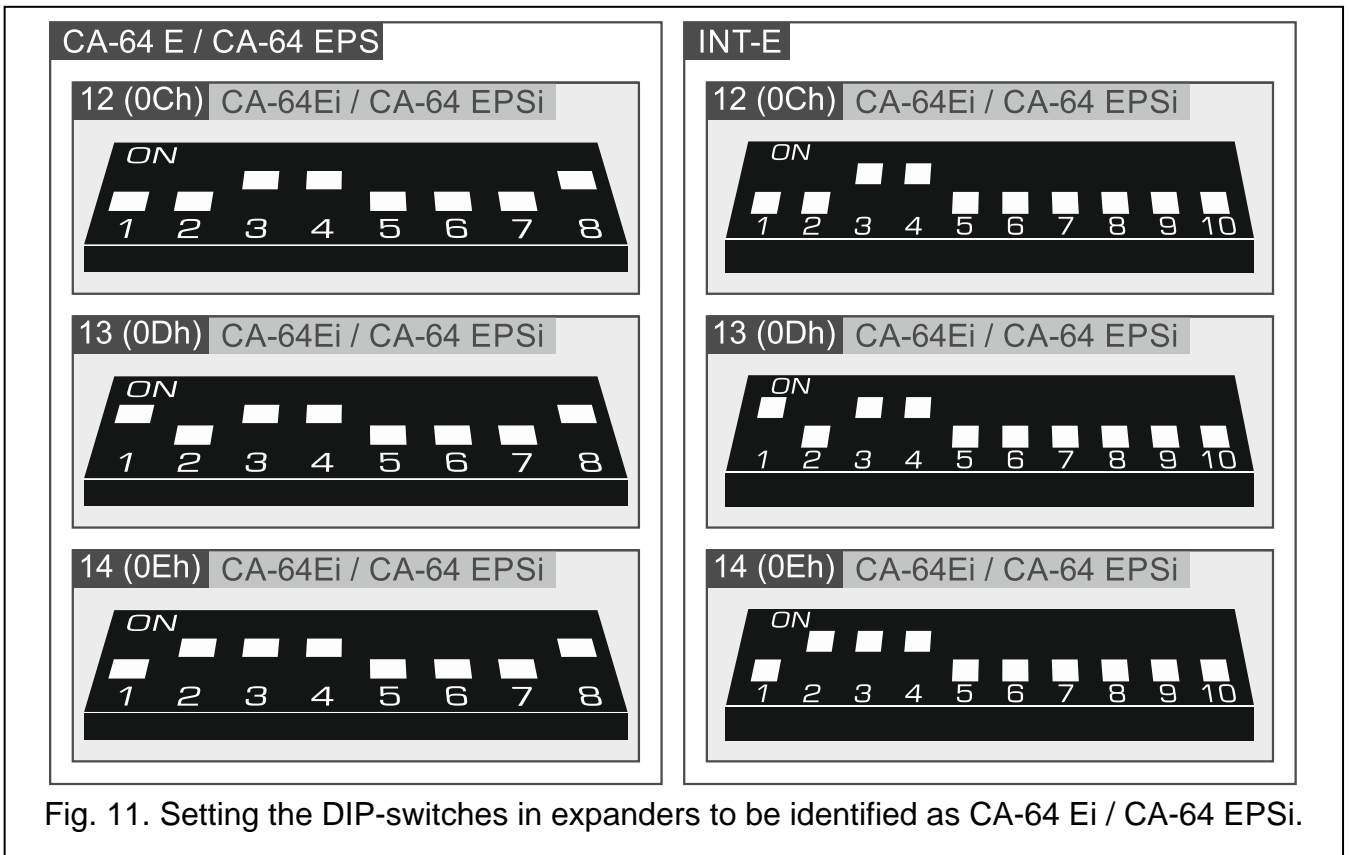

Fig. 11. Setting the DIP-switches in expanders to be identified as CA-64 Ei / CA-64 EPSi.

Table 2 shows numbering of the expander zones depending on the address set. If a number of expander zone coincides with a number of mainboard zone or a number of wireless zone, the expander zone will not be supported.

Expander address		Zone numbers
decimally	hexadecimally	
12	0C	7-14
13	0D	15-22
14	0E	23-30

Table 2.

5.5.6 Connecting the hardwired output expander

One INT-O / INT-ORS / CA-64 O / CA-64 OPS expander can be connected to the control panel. This enables expansion of the system by adding 8 programmable wired outputs. Address 15 (0Fh) must be set in the expander. In the case of the INT-ORS expander, you must also use the DIP-switches to define how the expander is to be identified (for detailed information please refer to the manual delivered with the expander).



The INT-O expander is identified as CA-64 O (the dedicated power supply not connected to the expander) or CA-64 OPS (the dedicated power supply connected to the expander).

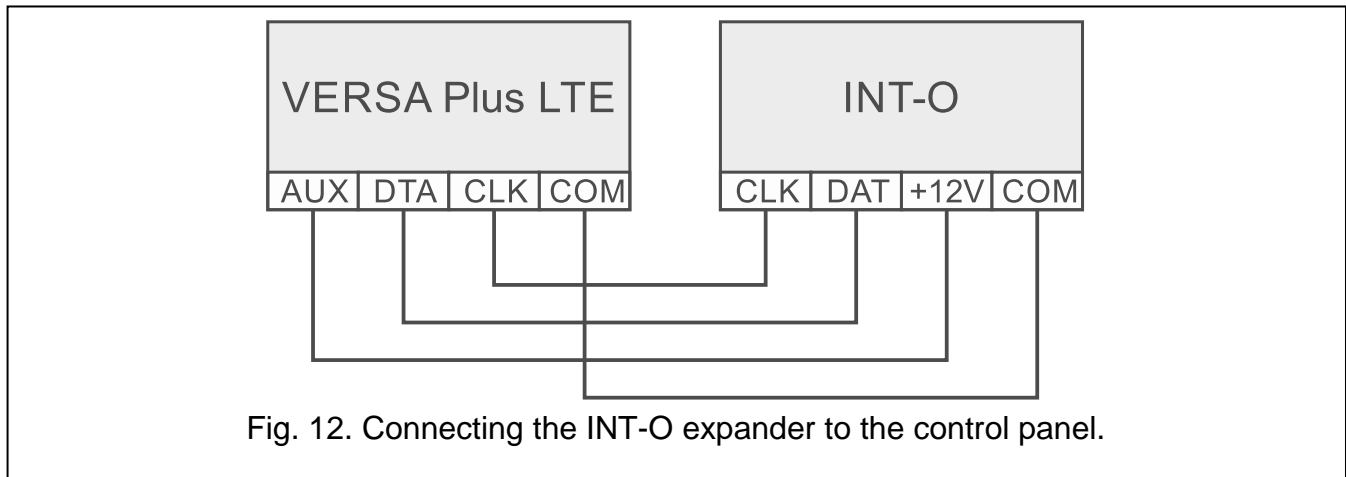

Fig. 12. Connecting the INT-O expander to the control panel.

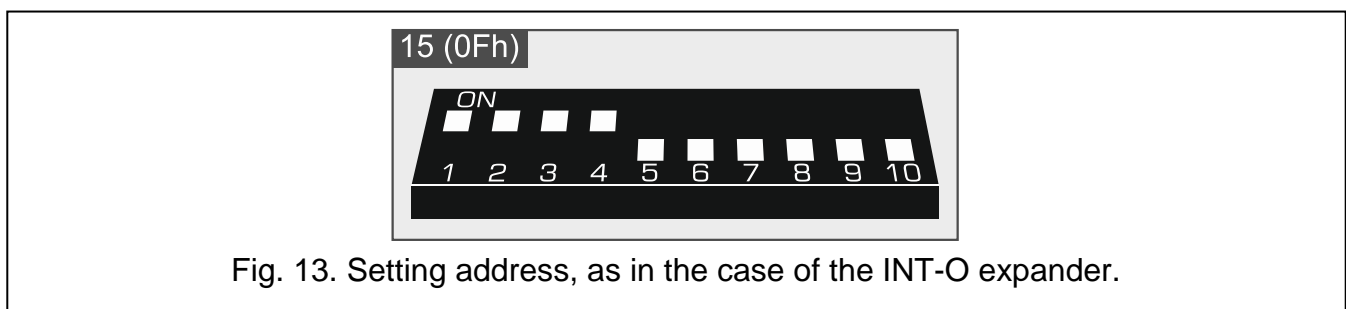

Fig. 13. Setting address, as in the case of the INT-O expander.

5.5.7 Connecting proximity card arm/disarm devices

Up to 6 INT-CR / INT-IT / INT-IT-2 devices can be installed in the system. Addresses from the 16 (10h) to 21 (15h) range should be set in the devices.



All the proximity card arm/disarm devices are identified by the control panel as the INT-IT module.

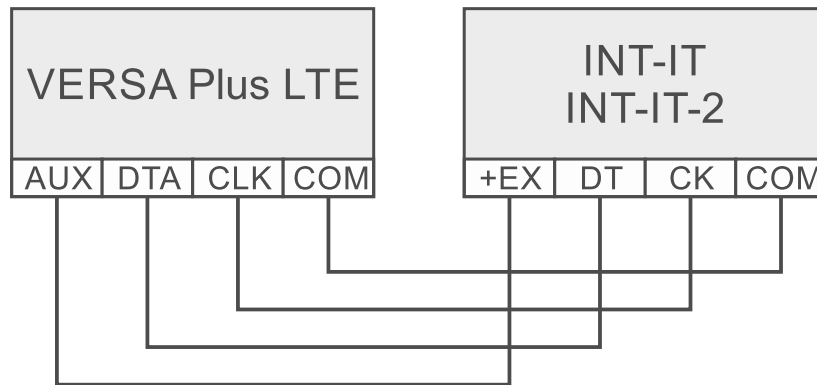

Fig. 14. Connecting the INT-IT / INT-IT-2 module to the control panel.

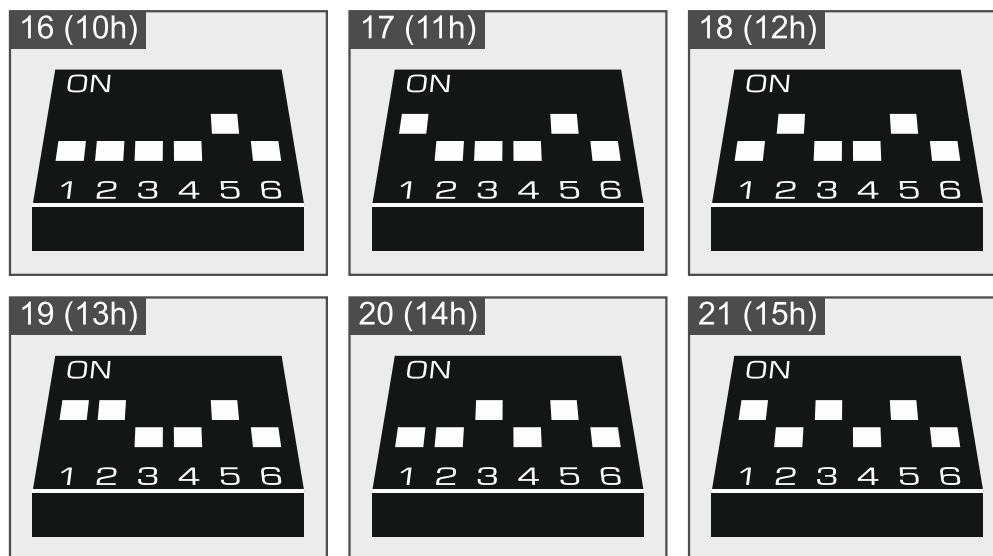

Fig. 15. Setting the address, as in the case of the INT-IT / INT-IT-2 module.

5.6 Connecting the detectors

How the detector is connected to the zone must be suitable for the configuration chosen for that zone. The zones on the control panel mainboard support the following configurations:

NC – the wiring type dedicated to connecting devices with the NC (normally closed) alarm output. Opening the circuit will trigger an alarm.

NO – the wiring type dedicated to connecting devices with the NO (normally open) alarm output. Closing the circuit will trigger an alarm.

EOL – this wiring type may be used to connect devices having the NC or NO alarm output. Closing or opening the circuit will trigger an alarm.

2EOL/NC – the wiring type recommended to connect detectors having the NC alarm output and a tamper output. The zone can recognize 3 states: normal, alarm and tamper.

2EOL/NO – the wiring type similar as 2EOL/NC, but for detectors with the NO alarm output.

Roller – the wiring type dedicated to connecting roller shutter detectors.

Vibration – the wiring type dedicated to connecting shock detectors. The zone will also accept connection of a detector with the NC alarm output (e.g. a shock detector and a magnetic contact can be connected in series).

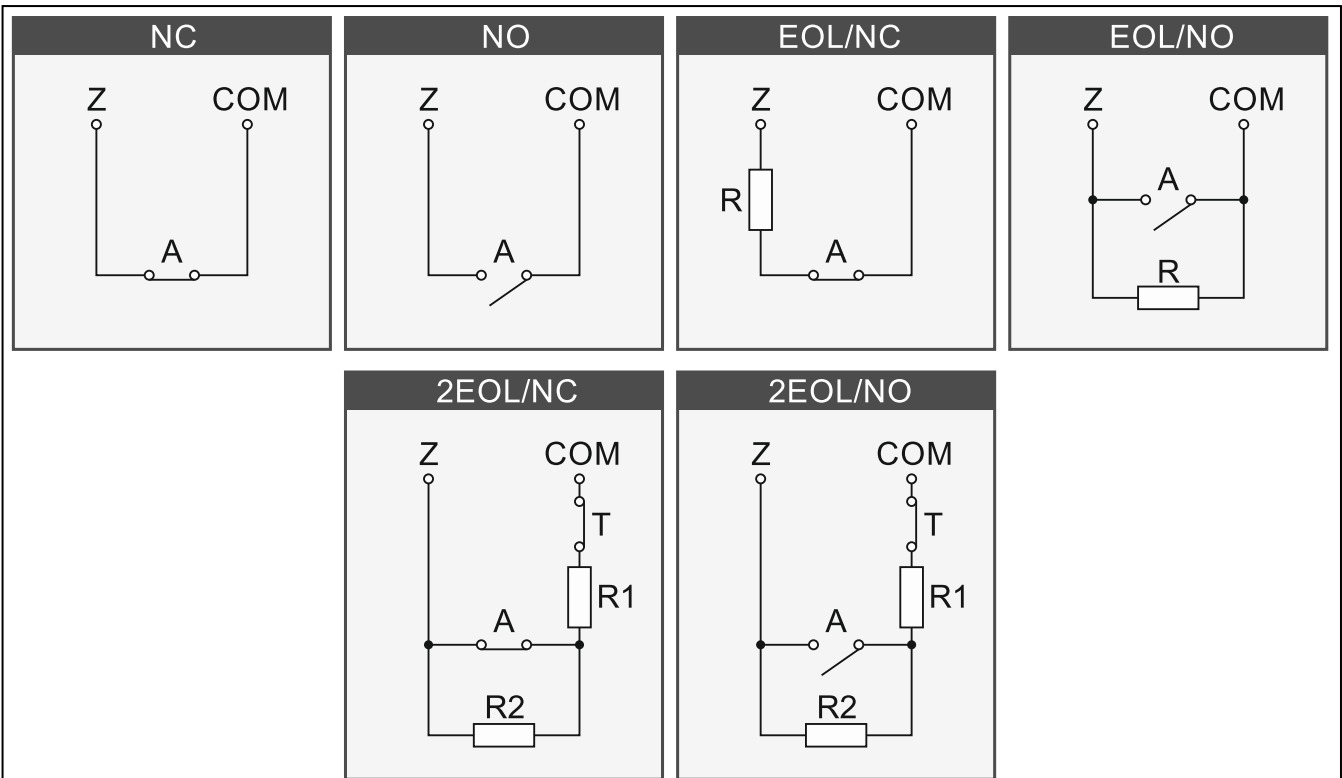

Fig. 16. The ways to connect detectors to zones. The detector outputs are designated with letters: A - alarm, T – tamper. $R=R1+R2$.

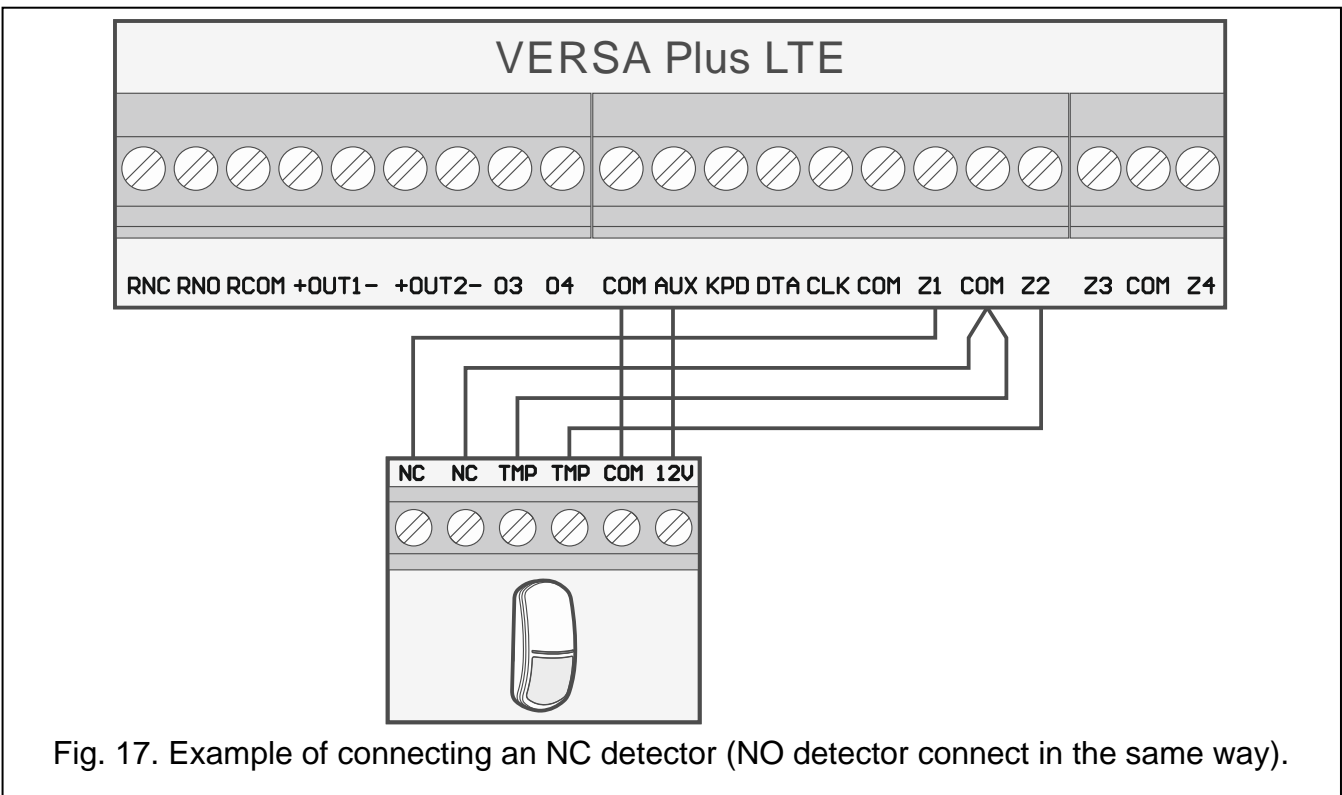

Fig. 17. Example of connecting an NC detector (NO detector connect in the same way).

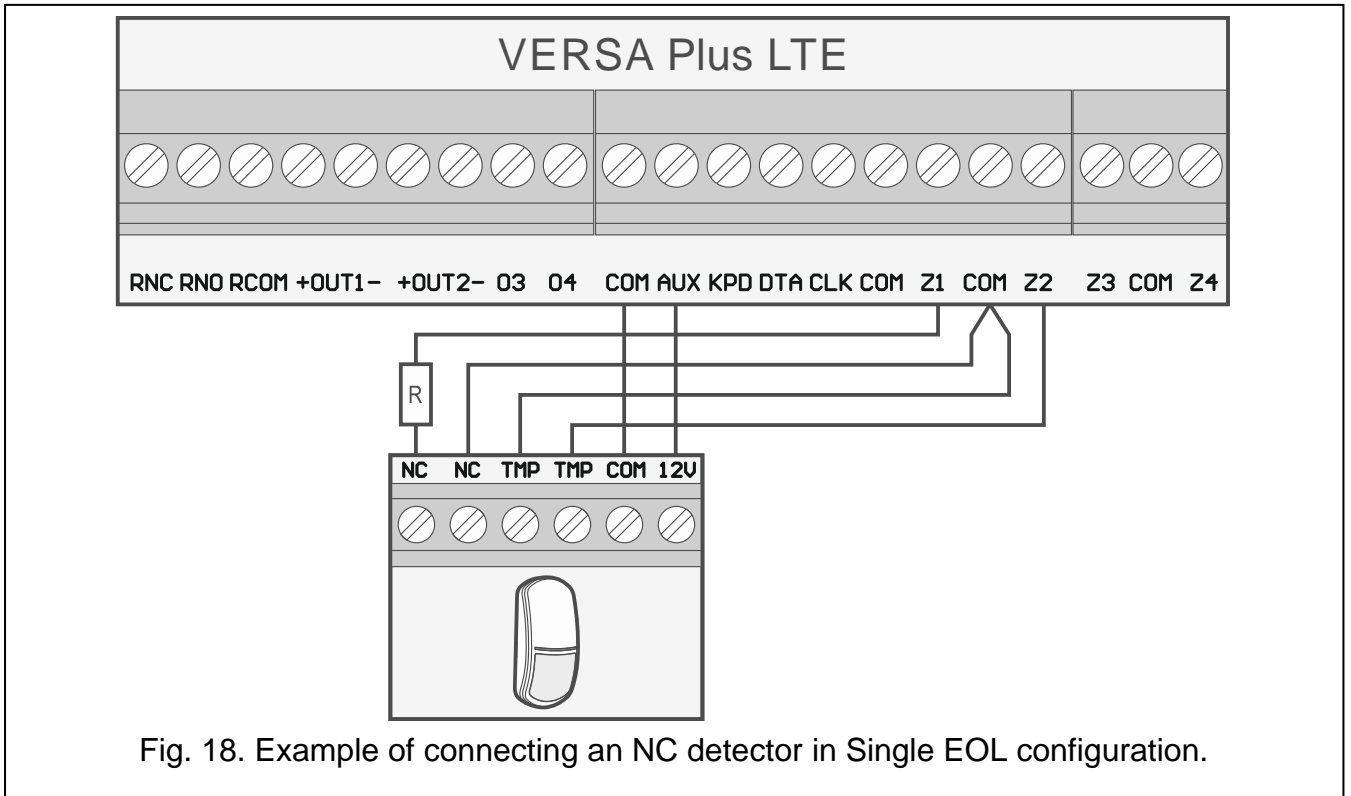

Fig. 18. Example of connecting an NC detector in Single EOL configuration.

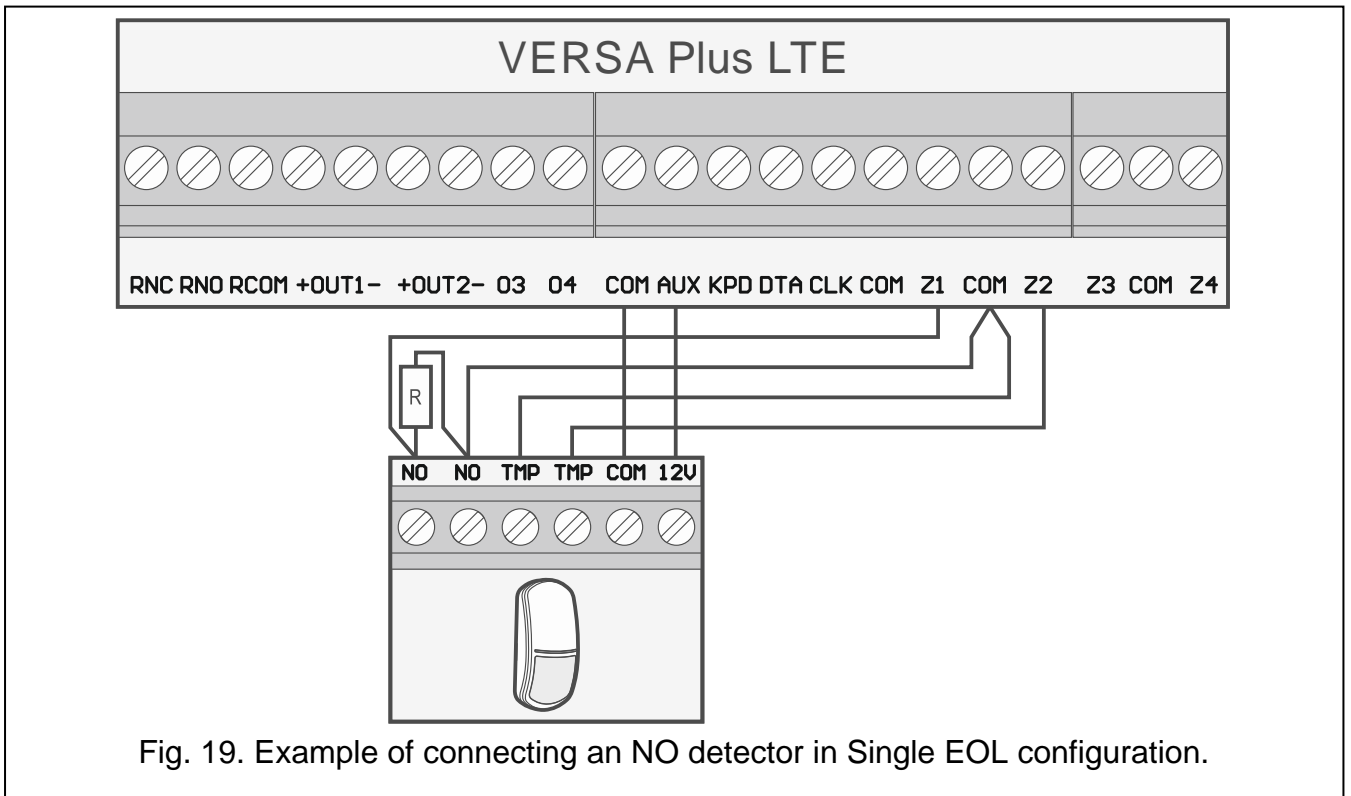
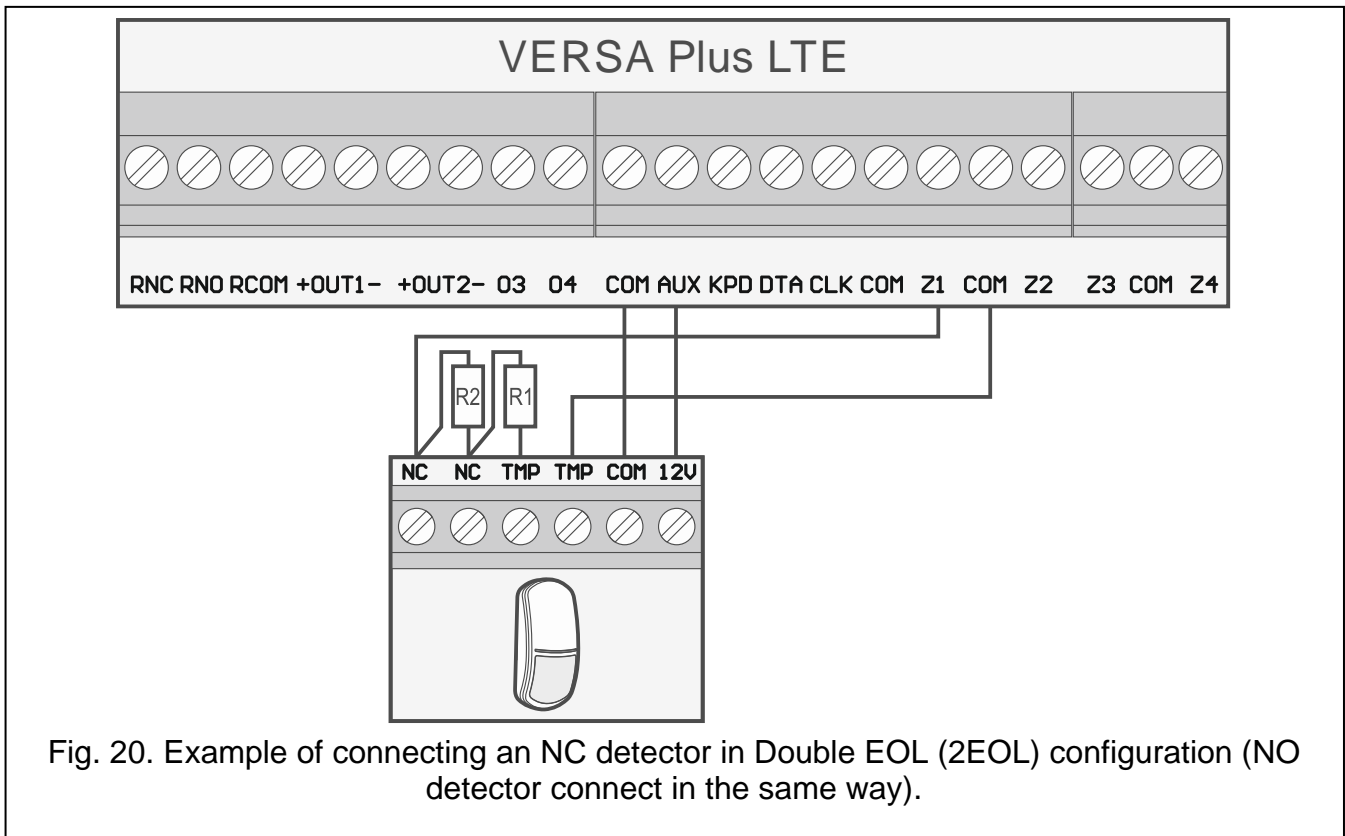

Fig. 19. Example of connecting an NO detector in Single EOL configuration.



5.6.1 End-of-line resistors

For the control panel mainboard zones, use a 2.2 k Ω resistor in Single EOL configuration and two 1.1 k Ω resistors in Double EOL (2EOL) configuration.

For the expanders identified by the control panel as CA-64 Ei and CA-64 EPSi, the EOL resistor value is programmable within the range from 500 Ω to 15 k Ω (the sum of programmable values must not exceed 15 k Ω – see the PROGRAMMING manual).



If the resistor value in the expander is not programmable, in Single EOL configuration, the 2.2 k Ω resistor is required, and in Double EOL (2EOL) configuration – two 1.1 k Ω resistors.

5.7 Connecting the sirens



It is recommended that the control panel be started without connected sirens. This will prevent accidental triggering of the alarm after the control panel is started.

Depending on the siren type:

- sirens without own power supply (e.g. SP-500, SP-4001, SP-4003, SPL-2010, SPW-100, SPW-210, SPW-220) – high-current outputs are to be used to trigger the signaling,
- sirens with own power supply (e.g. SP-4002, SP-4004, SP-4006, SP-6500, SPLZ-1011, SD-3001, SD-6000) – it is recommended to use low-current outputs to trigger the signaling, and high-current ones – to supply power.

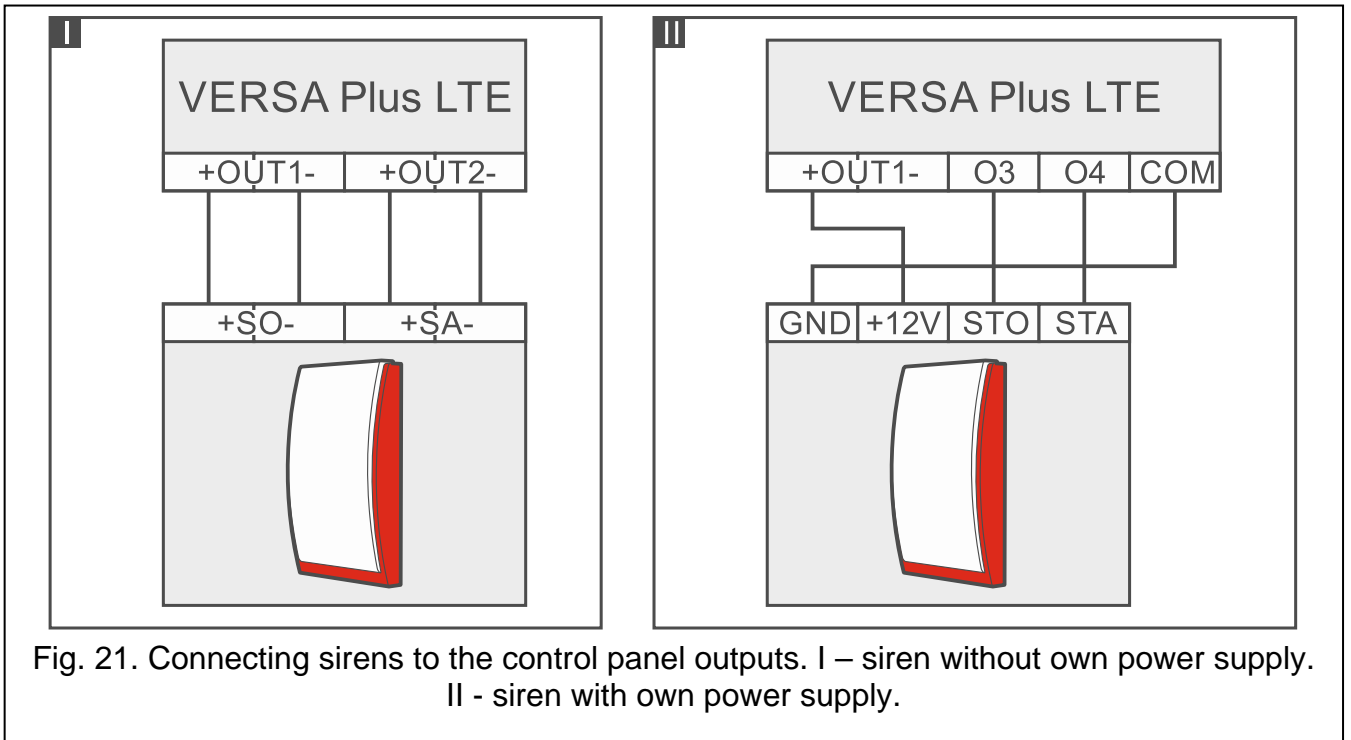

Fig. 21. Connecting sirens to the control panel outputs. I – siren without own power supply. II - siren with own power supply.

5.8 Connecting the radio monitoring transmitter

The O3 and O4 outputs of the control panel can be used for control of the NR2-DSC radio monitoring transmitter (NEMROD system – format PC-16 OUT) manufactured by NOKTON. In such a case, the SERIAL DATA ON OUT 3/4 global option must be enabled in the control panel (see PROGRAMMING manual). Table 3 contains description of the connector contacts in the NOKTON NR2-DSC transmitter, used for connecting to the VERSA Plus LTE control panel.

Contact number	Description	Connection method
2	alternating voltage check	connect to control panel AC terminal
12	power supply	connect directly to battery “+” through 2 A fuse
13	common ground	connect to control panel COM terminal
14	TAKT	connect to control panel O3 terminal
15	PGM	connect to control panel O4 terminal

Table 3.



Never connect the contact 13 (common ground) of the NR2-DSC transmitter connector to the battery “-”. Connecting the transmitter common ground to the battery “-” may not only cause quick discharge of the battery, but even damage to the control panel.

Never connect the contact 13 (common ground) of the NR2-DSC transmitter connector to the control panel COM terminal and the battery “-”, as it may cause damage to the control panel.

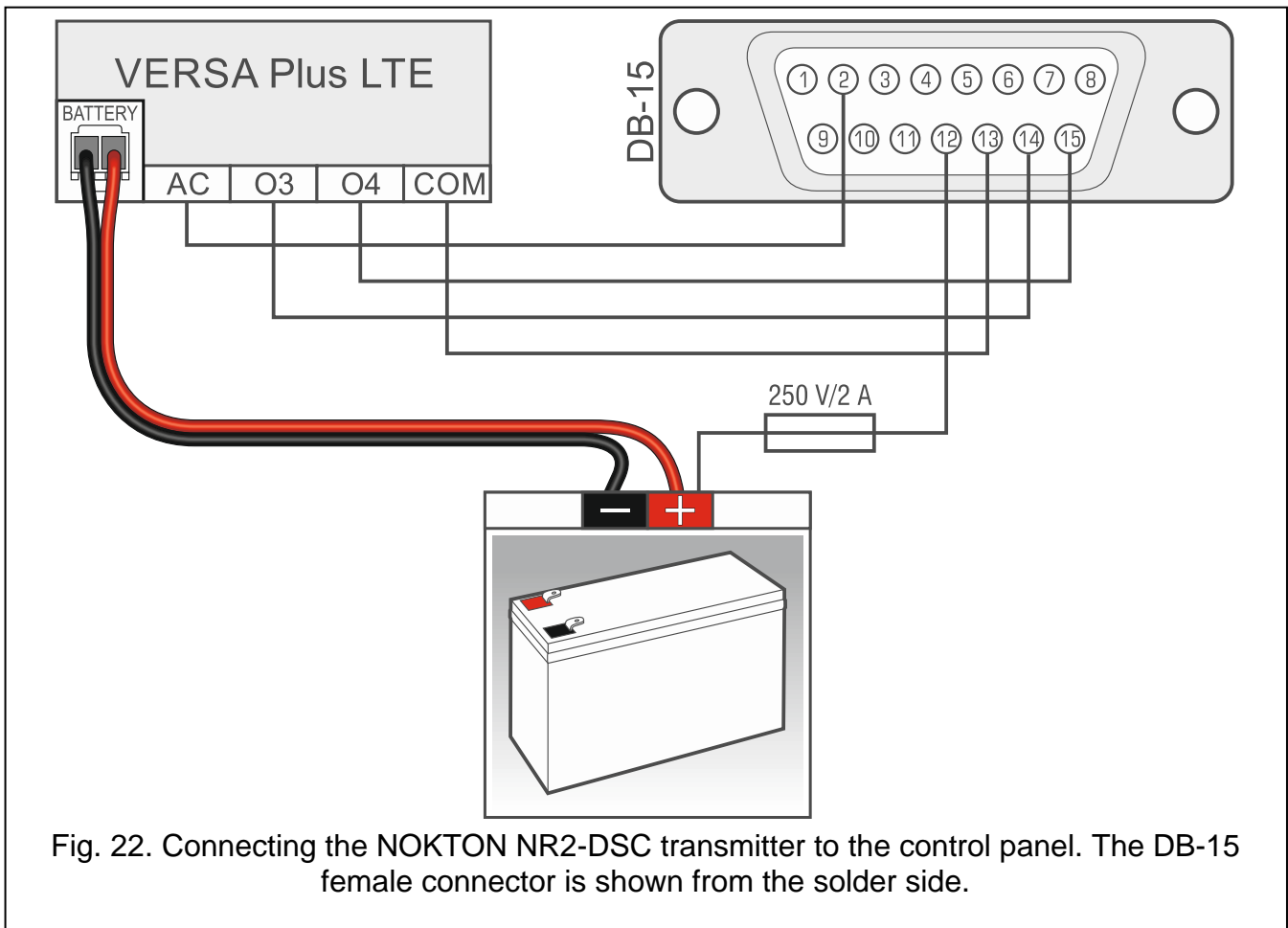

Fig. 22. Connecting the NOKTON NR2-DSC transmitter to the control panel. The DB-15 female connector is shown from the solder side.

5.9 Connecting the analog telephone line



Do not send telephone signals and alarm system signals by one multicore cable. This may cause damage to the system in case of a high-voltage punch-through coming from the telephone.

The control panel may only be connected to analog PSTN lines.

The system installer should inform the user about the way of connecting the control panel to the telephone network.

The control panel must be connected directly to the telephone line (terminals marked TIP, RING). Other devices using the telephone line (e.g. telephone, fax) should be connected after the control panel (terminals marked T-1, R-1). Hence the telephone line should be connected to the control panel using a four-wire cable. When connected in this manner, the control panel will be able to completely capture the line for the time of making a call. This will prevent the control panel telephone dialer from being blocked, e.g. by lifting the telephone receiver (such a situation would take place, if the control panel was connected to the telephone line after the telephone set).

If the ADSL service is used on the premises where the control panel is installed, the control panel should be connected after the ADSL filter, and the other devices using the analog telephone line should be connected to the control panel.

To protect the telephone communicator against over-voltage, connect the \perp terminal to the protective earth conductor (PE) of the 230 VAC mains. To make the connection, use a conductor with $\geq 0,75 \text{ mm}^2$ cross-section. Never connect the \perp terminal to the neutral conductor (N).

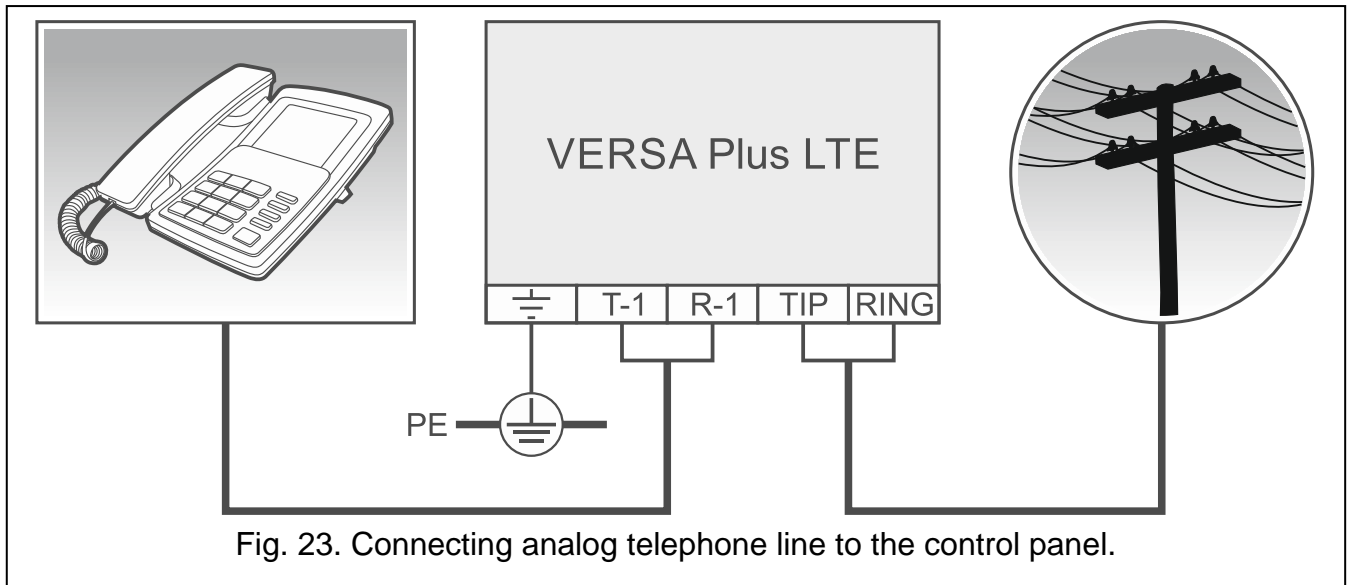

5.10 Connecting the Ethernet network



The device is designed to be used only in the local area networks (LAN). It must not be connected directly to the public computer network (MAN, WAN). For establishing connection with public networks, use a router or xDSL modem.

To connect the control panel to the Ethernet network, use a 100Base-TX standard compliant cable (identical to that used for connecting computers to the network). The cable must be terminated with a RJ-45 plug.

5.11 Connecting the INT-AVT terminal

One INT-AVT terminal (manufactured after 1 December 2014), provided with a microphone and a speaker, can be connected to the control panel. Owing to the terminal, the system users will be able, after establishing telephone connection with the control panel, to use the listen-in feature and talk with the people staying inside the protected premises.

5.11.1 Mounting the INT-AVT terminal

When selecting the installation place, bear in mind that curtains, drapes, upholstery, acoustic tiles, etc. absorb sound and, as a result, make it difficult, if not impossible, to use the listen-in feature. It is not advisable to install the terminal in the vicinity of equipment which generates noise during operation (e.g. fans, air conditioners, refrigerators).

1. Remove the screw, lift the enclosure cover and detach it (see Fig. 24). The cover will still be connected to the base by the speaker wires.



When opening the INT-AVT terminal enclosure be careful not to rip off the speaker attached to the base.

Any changes in the construction of the INT-AVT terminal may result in malfunctioning of the device.

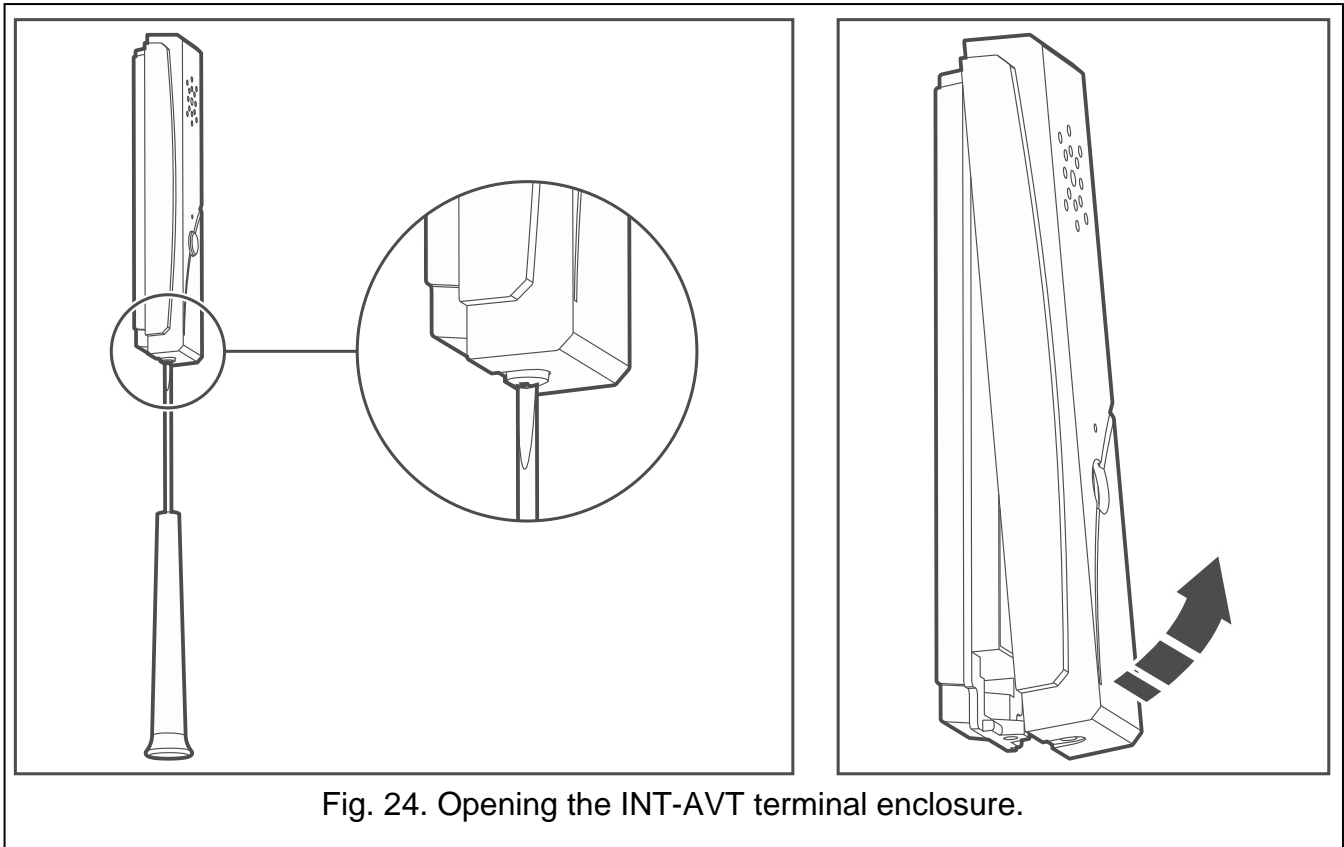

Fig. 24. Opening the INT-AVT terminal enclosure.

2. Disconnect the speaker plug from the electronics board.
3. Put the enclosure base to the wall and mark the location of mounting holes.
4. Drill the holes for wall plugs (screw anchors).
5. Run wires through the opening in the enclosure base.
6. Using wall plugs (screw anchors) and screws, fasten the enclosure base to the wall.
7. Connect the INT-AVT terminals to the corresponding terminals of the control panel (see Fig. 25).
8. Connect the speaker plug to the electronics board.
9. Replace the cover and then lock it with the screw.

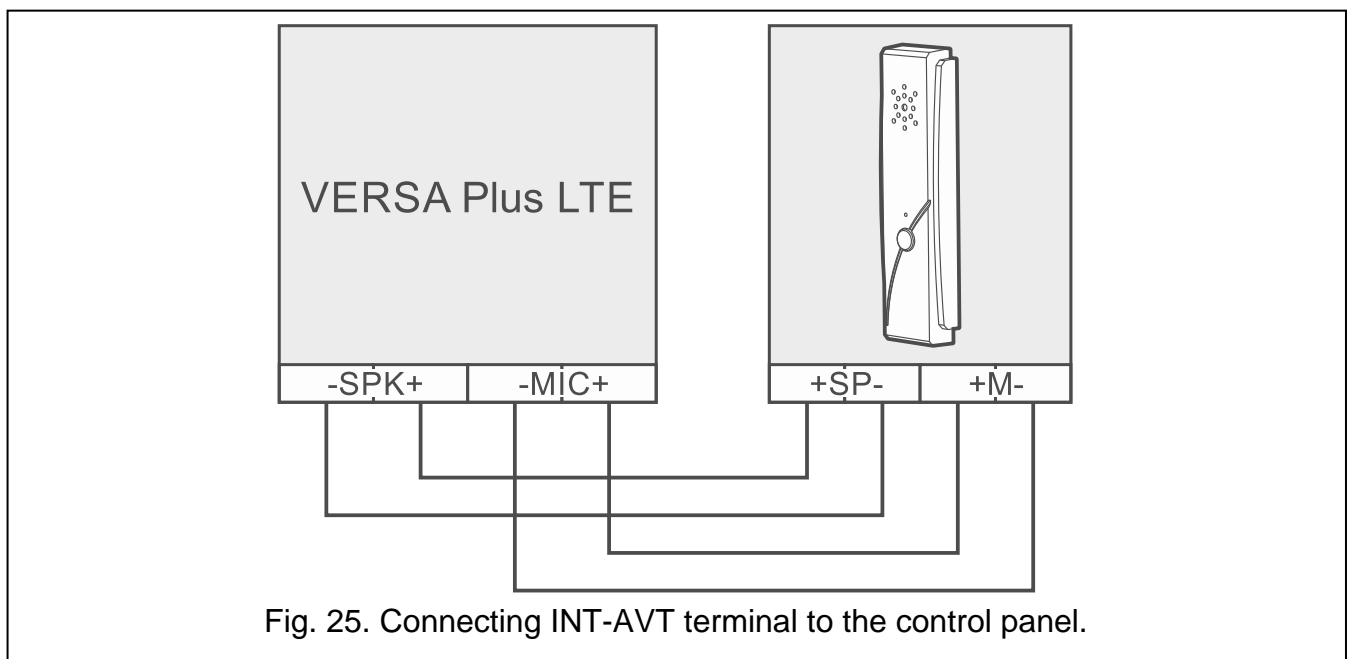

Fig. 25. Connecting INT-AVT terminal to the control panel.

5.12 Connecting the power supply and starting the control panel



Do not connect power until all installation operations are completed.

5.12.1 Main power supply

The control panel requires 18 VAC ($\pm 10\%$) power supply. It is recommended that a transformer with up to 40 VA rating be used.

The transformer should be permanently connected to the 230 VAC mains supply. Before you make the cabling, familiarize yourself with the electrical installation of the facility. Make sure that the circuit you choose for powering the control panel will be always alive. The circuit must be provided with a 2-pole switch disconnecter with at least 3 mm contact separation and/or short-circuit protection with a 16 A time-delay fuse. The owner or user of the alarm system should be instructed on how to disconnect the transformer from the mains (e.g. by indicating the fuse which protects the control panel supply circuit).



Do not connect two devices with power supply to one-section transformer.

Before connecting transformer to a circuit from which it will be powered, make sure the circuit is de-energized.

5.12.2 Backup power supply

A 12 V lead-acid sealed battery should be connected to the control panel as a backup power source. The battery capacity must be adequately selected to match current consumption in the system. According to EN 50131 Grade 2, the battery must ensure operation of the system without mains supply for 12 hours.

If the battery voltage drops below 11 V for longer than 12 minutes (3 battery tests), the control panel will indicate battery failure. When the voltage goes down to approx. 10.5 V, the battery will be disconnected.



Do not connect deeply discharged battery to the control panel (with voltage across unloaded terminals below 11 V). The battery should be precharged with a proper charger.

The used batteries must not be discarded, but should be disposed of in accordance with the existing rules for environment protection.

5.12.3 Control panel power-up / start-up procedure

1. De-energize the 230 VAC circuit to which the transformer is to be connected.
2. Connect the 230 VAC wires to the terminals of transformer primary winding.
3. Connect the terminals of transformer secondary winding to the control panel AC terminals. To make the connection, use flexible conductors with a cross-section of 0.5 – 0.75 mm², or rigid conductors with a cross-section of 1 – 2.5 mm².
4. Connect the battery to the dedicated leads (positive terminal to RED lead, negative terminal to BLACK lead). If the battery has screw-type cable lugs, use adapters delivered with the control panel (do not cut off the battery cable lugs). **The control panel will not start after connecting the battery alone.**
5. Turn on 230 VAC power supply in the circuit to which the transformer is connected. The control panel will start operating.



The above mentioned power-up sequence (first the battery, then the 230 VAC mains) will ensure proper operation of the power supply unit and the electronic protection circuits, thus preventing damage to the alarm system components caused by installation mistakes, if any.

If it is necessary to de-energize the control panel, turn off the main power supply (AC) first, and the backup power supply (battery) afterwards. Observe the above described procedure when reconnecting the power supply.







5.12.4 Emergency procedure of the control panel start-up

If the control panel fails to start properly, keypads are not supported, codes are not accepted by the control panel etc., despite all connections having been made correctly, follow the steps below:

1. Turn off the control panel power supply (first disconnect the AC power, and then the battery) and make sure the control panel is not connected to the computer by a USB cable.
2. Put a jumper on the pins located on the control panel mainboard (designated ⑤ in Fig. 2 – p. 9).
3. Turn on the control panel power supply (first connect the battery and then the AC power).
4. Wait a few seconds and remove the jumper from the pins. The control panel will enter the service mode. The service mode menu will be displayed on the keypad with the lowest address (in the case of a wireless keypad, the menu will be displayed on pressing any key).



If the SERVICE MODE FROM RESET PINS option is disabled in the control panel then, depending on the type of keypad in which the lowest address is set:

- LCD: the ,  and  (of the second partition) LEDs will be lit, and the message “Restore factory settings ? 1=Yes” will come up on the display,
- LED: the  and  (of the second partition) LEDs will be lit and the  LED will be flashing rapidly.

Pressing the  key will reset the control panel to its factory settings, but will enable entering the service mode.

5.12.5 First steps after starting-up the control panel

Having started the control panel with factory defaults:

1. Set individual, correct addresses in the keypads.
2. Run the identification function for devices connected to the communication bus of the control panel.

Programming the control panel settings will only be possible after completion of the above steps.

5.13 Programming addresses for the hardwired keypads

Each keypad connected to the control panel must have an individual address set within the 0 to 5 range. By default, address 0 is set in all wired keypads. When started with factory default settings, the control panel will support all keypads connected to the bus, irrespective of what addresses are set in them. Thus it is possible to set correct individual addresses in the keypads.











Remember to program an individual address if a new keypad is connected to the already functioning alarm system.

5.13.1 Programming the address by means of the service function



The address programming function can be started from either a wired or wireless keypad, but it will only allow setting addresses in the wired keypads.

1. Enter the service code (by default 12345) and press the  key.
2. Press in turn the    keys. The service mode will start.
3. Press in turn the     keys. The KEYPADS ADDR. function will start. All LEDs designated with icons will start flashing in keypads and information on the current address will be presented by means of:
LCD: displayed message – see Fig. 26,
LED: rapid flashing of the LED designated with the number corresponding to the keypad address (for address 0 – LED 30) – see Fig. 27.



n=0...5 currently set keypad address

Fig. 26. Programming LCD keypad address.

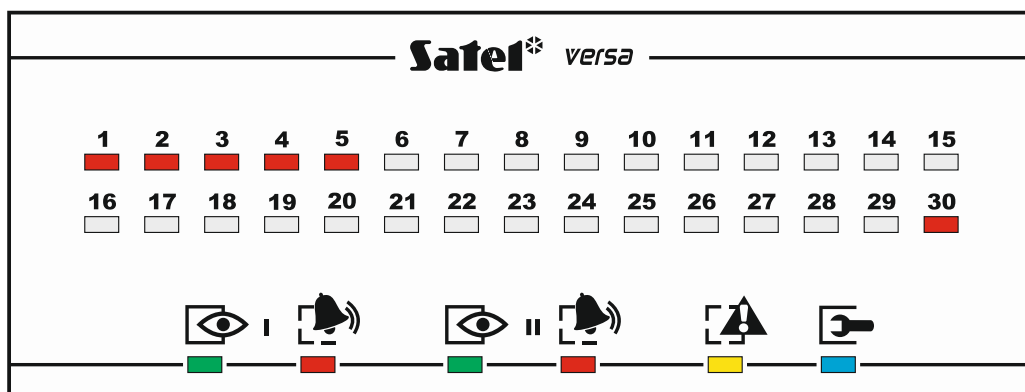



Fig. 27. Programming LED keypad address. LEDs designated with numbers from 1 to 5 and 30 are used for address presentation (30 – for address 0). The LED corresponding to the current address is flashing rapidly, the other ones are lit.

4. In the keypad in which a new address is to be set, press the key number corresponding to the new address. The address change will be confirmed by four short beeps followed by a long one.
5. Press the  key to finish the function. The keypad will be restarted. The function will be finished automatically after 2 minutes since it was launched.

5.13.2 Programming the address without entering the service mode

This way of address programming is useful when the keypad operation is blocked and starting the service mode is impossible.

1. Power off the keypad.
2. Disconnect cables from the keypad CLK and DTA terminals.
3. Short the CLK and DTA keypad terminals.
4. Power on the keypad. The LEDs designated with icons will start flashing in the keypads and information on the current address will be presented by means of:
LCD: displayed message,
LED: rapid flashing of the LED designated with the number corresponding to the keypad address – see Fig. 27.

5. Press the key with the number corresponding to the new address. The address change will be confirmed by four short beeps followed by a long one. Pressing  allow to change the address again (the keypad restart will follow and information on the current address will be displayed again).
6. Power off the keypad.
7. Open the CLK and DTA keypad terminals.
8. Connect cables properly to the CLK and DTA keypad terminals.
9. Power on the keypad.









5.14 Identification of devices connected to the bus

Devices connected to the communication bus will not be properly supported, unless they have been identified by the control panel. Identification of the devices is required after the first start-up of the control panel and then each time after a new device is added or the address was changed in a device supported by the control panel.



Disconnecting an identified device from the communication bus will trigger the tamper alarm.

5.14.1 Starting the identification function from keypad

1. Enter the service code (by default 12345) and press the  key.
2. Press in turn the    keys. The service mode will start.
3. Press in turn the     keys. The IDENTIFICATION function will start. Three short beeps will indicate that identification has been completed and information on the identified devices will be presented (on the display in the LCD keypad and by means of LEDs in the LED keypad).
4. Press the  key to quit the function.



If the identification is terminated by two long beeps, this means that a wrong address is set in the device connected to the communication bus (unsuitable for this type of device or the same in at least two devices). The displayed message (in the LCD keypad) or the flashing LED corresponding to the device address (in the LED keypad) will be helpful in diagnosing the problem. Press , set the correct address in the device, and then restart the IDENTIFICATION function.

5.14.2 Starting the identification function from DLOADX program

1. Click on the  button in the main menu. The “VERSA – Structure” window will open.
2. Click on the “Hardware” tab.
3. Click on the “Expanders” branch.
4. Click on the “Identification” button to run the identification function.
5. After the identification is finished, a window will appear with a prompt whether to read the data. Click “OK”.

5.15 Installing the SIM card

Slots on the mainboard make it possible to install two nano-SIM cards.



If the control panel is to transmit data over the cellular network, it is recommended that you use SIM cards with a dedicated tariff plan for M2M (machine-to-machine) communication.

If the SIM card requires entering the PIN code, program the PIN code using the DLOADX program (see the PROGRAMMING manual) before the SIM card is inserted.

If an incorrect PIN code has been programmed, the control panel will report a trouble at the first attempt to use the code. Another attempt to use the PIN code will only be possible after a few minutes. After the third attempt to use the wrong PIN code, the SIM card will be blocked. To unblock the SIM card, remove it and insert it into a cellular phone (the PUK code must be entered).

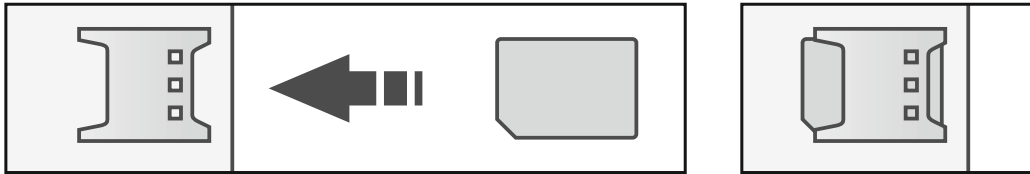

Fig. 28. Installing the SIM card.

5.16 Connecting the computer to the control panel

Using a computer, you can configure the alarm system / voice module (DLOADX program / VG-SOFT) or update the control panel firmware. The communication is encrypted. The computer can be connected to the control panel through a USB port. After connecting the control panel to the computer, the Windows system will automatically detect that a new device is connected and will install system drivers for the HID interface device.

5.17 Installation of ABAX 2 / ABAX wireless devices



This section does not cover installation of the wireless keypads. They constitute a separate category of devices and should be installed according to the manual delivered with the device.

If an ABAX 2 (ACU-220 / ACU-280) / ABAX (ACU-120 / ACU-270 / ACU-100 / ACU-250) wireless system controller is connected to the control panel, you can proceed to installation of ABAX 2 / ABAX wireless devices after control panel start-up and controller identification by the control panel. Before installing a wireless device, check the level of radio signal received by the device from controller and by the controller from device at the planned installation place. The ARF-200 / ARF-100 tester is a useful tool to check the signal level. The level of signal received by device/controller may not be lower than 40%. If the radio signal level at the planned installation place is too low, select another installation location. Sometimes it is sufficient to move the device ten or twenty centimeters. You can install the device permanently only after reaching the optimum level of radio signal.

The wireless devices must be registered to the alarm system. This can be done using the DLOADX program or LCD keypad. When adding (registering) a device, you must enter its serial number. The serial number sticker is affixed to the device (location of the sticker is indicated in the manual of the device). The serial number of each ARF-200 / ARF-100 tester is 0000500.



Data on wireless devices are stored in the controller. If you connect to the control panel a controller with registered devices, during identification procedure, these devices will be automatically assigned to the system zones / outputs.

5.17.1 Adding new ABAX 2 / ABAX wireless devices



Before adding an ABAX 2 device that was previously registered to the ABAX 2 / ABAX system, you must restart it (remove the battery / power the device off for 30 seconds).

Most of the ABAX 2 wireless devices are identified in the alarm system by the names known from the ABAX system.

Some ABAX 2 devices you can only add by using the DLOADX program (e.g. ACD-220, ACMD-200 and ADD-200 detectors).

The control panel can support up to 30 wireless devices. Each position on the device list represents one wireless zone or one wireless zone and one output.

When registered, some devices will occupy two or more positions on the list. Therefore, the actual number of devices that can be registered depends on how many positions will be taken up by individual devices. For example, the ACX-220 / ACX-200 expander can take up 4 positions. After registering it to the system, the pool of positions for further devices will decrease by 4 (e.g. if there were 30 positions available before registering the expander, 26 positions will remain after registering the expander, i.e. you will still be able to register up to 26 devices).



For some wireless devices, you can select whether the device will take up one or two positions (channels) on the list of devices. If you select one position for ABAX device:

- AMD-101 – only additional NC input will be supported,*
- AMD-102 – only additional inputs (roller shutter and NC) will be supported;*
- AOD-200 – only the motion detector will be supported;*
- AVD-100 – only the vibration detector will be supported.*

When adding device you can select the alarm system zone to which you want to assign a device. It can be any zone to which no wireless device is still assigned. If the device takes up more than one position on the list of devices, additional zones will be assigned to the device automatically (these will be zones immediately following the selected one).

If the device is to be also assigned to an output, the output number will be the same as that of the selected zone.



The control panel does not support wireless outputs with numbers from 13 to 30. Therefore it is not recommended that you assign any devices that are at the same time assigned to outputs (e.g. sirens, controllers, etc.) to the zones from 13 to 30.

DLOADX program

You can add ABAX 2 / ABAX wireless devices in the “VERSA – Structure” window, “Hardware” tab, after clicking on the ABAX 2 / ABAX controller name in the list of devices.









1. In the “Zones/Outputs” tab, click on the “Read” button to read the data related to wireless devices from the controller (these data are not read after clicking on the  button in the main menu).
2. Click on the zone to which a new wireless device is to be assigned (you can also select the zone later in the “New wireless dev.” window).
3. Click on the “New device” button. The “New wireless dev.” window will open.
4. Enter the serial number of the device being added in the “Serial number” field.
5. Power on the device (install the battery in the device, turn on the device power, etc.).
6. A message will confirm that the device has been added (unless you have entered an invalid serial number, of which you will be informed by a message).
 - 6.1. Device type will be displayed.
 - 6.2. A new name of the zone to which the device is to be assigned will be displayed. You can change the name. If the device occupies two or more positions on the

device list, the same name will be given to the other zones. If the device is to be assigned to outputs, the outputs will be given the same name.

- 6.3. In the “Zone” field, select the number of the zone to which you want to assign the device (if you have not done this before or if you want to change the previously selected number).
- 6.4. For some devices you can select if the device is to occupy one or two positions on the list of devices.
7. Click on the “OK” button (you can click on the “Quit” button to cancel adding a new device or on the “Next” button to proceed to adding a next wireless device). The “New wireless dev.” window will close.
8. Click on the “Write” button to write the new wireless device data to the controller (these data will not be written after clicking on the  button in the main menu).

LCD keypad

You can add ABAX 2 / ABAX wireless devices in the service mode by means of the NEW DEVICE function (SERVICE MODE ►2. HARDWARE ►1. KPDS. & EXPS. ►3. WIRELESS DEV. ►1. NEW DEVICE).

1. Start the NEW DEVICE function.
2. When the “Serial number” is displayed, enter the serial number of the device being added.
3. Press .
4. When the “Open device tamper” command is displayed, power on the device (insert the battery into the device, turn on the device power, etc.).
5. Type and serial number of the device will be displayed (if nothing happens, you might have entered a wrong serial number – press  to quit the function).
6. Depending on the device:
 - if the device takes up only 1 zone or you cannot select how many positions the device is to occupy on the device list – press .
 - if you can select whether the device will take up one or two positions (channels) on the list of devices, a special message will inform you about it – press  (the device will occupy 1 position) or  (the device will occupy 2 positions).
7. Use the  and  keys to select the zone to which you want to assign the device.
8. Press .
9. The new name of the zone / output to which the device has been assigned will be displayed. You can change that name.
10. Press .
11. If the device occupies two or more zones / outputs, the name giving procedure is repeated for them.
12. In the next steps, you can configure the device settings (see the PROGRAMMING manual).

5.17.2 Removing ABAX 2 / ABAX wireless devices

DLOADX program



You can remove ABAX 2 / ABAX wireless devices in the “VERSA – Structure” window, “Hardware” tab, after clicking on the ABAX 2 / ABAX controller name in the list of devices.

1. In the “Zones/Outputs” tab, click on the “Read” button to read the data related to wireless devices from the controller.

2. Click on the device you want to remove (if the device occupies two or more positions on the list, you can click on any of them).
3. Click on the “Delete” button. The “Confirm” window will open.
4. Click on the “Yes” button. The “Confirm” window will close.
5. Click on the “Write” button to save the changes to the controller.

LCD keypad

You can remove ABAX 2 / ABAX wireless devices in the service mode by means of the REMOVE DEVICE function (SERVICE MODE ►2. HARDWARE ►1. KPDS. & EXPS. ►3. WIRELESS DEV. ►3. REMOVE DEVICE).

1. Start the REMOVE DEVICE function. List of wireless zones will be displayed.
2. Use the  and  keys to select the zone to which the device you want to remove is assigned.
3. Press .
4. When a prompt will be displayed asking you whether to remove the device (type and serial number of the device will be displayed), press .

5.18 Installation of MICRA (433 MHz) wireless detectors

 *MRU-300 repeater is treated as a wireless detector (it is identified as the MMD-300 detector).*

If the MICRA wireless system controller (VERSA-MCU) is connected to the control panel, you can proceed to installation of the MICRA (433 MHz) wireless detectors after control panel start-up and controller identification by the control panel. Before installation of the detector, register it in the controller and check, if transmissions from the detector located at the planned installation place can reach the controller. To send a transmission, you can e.g. open the detector tamper switch. If transmissions from the detector planned installation place do not reach the controller, select another location. Sometimes, it is sufficient to move the detector by some ten to twenty centimeters. Only after making sure that the controller receives transmissions from the detector, you can install the detector permanently.

The wireless detectors must be registered to the alarm system. This can be done using the DLOADX program or LCD keypad. When adding (registering) a detector, you must enter its serial number. The location of the serial number sticker is indicated in the detector manual.

 *Data on wireless detectors are stored in the controller. If you connect to the control panel a controller with registered detectors, during identification procedure, these detectors will be automatically assigned to the system zones.*

5.18.1 Adding new MICRA (433 MHz) wireless detectors

The control panel can support up to 30 wireless detectors.

When adding detector you can select the alarm system zone to which you want to assign a detector. It can be any zone to which no wireless detector is still assigned.



 *The MPD-310 and MPD-310 Pet detectors are identified as the MPD-300 detector.*

The MSD-350 detector is identified as the MSD-300 detector.

The MXD-300 detector is identified as the MMD-302 detector.











DLOADX program

You can add MICRA (433 MHz) wireless detectors in the “VERSA – Structure” window, “Hardware” tab, after clicking on the VERSA-MCU controller name in the list of devices.

1. Click on the “Read” button to read the data related to wireless detectors from the controller (these data are not read after clicking on the  button in the main menu).
2. Click on the zone to which a new wireless detector is to be assigned (you can also select the zone later in the “New wireless dev.” window).
3. Click on the “New device” button. The “New wireless dev.” window will open.
4. Enter the serial number of the detector being added in the “Serial number” field.
5. Open the detector tamper switch.
6. A message will confirm that the detector has been added (unless you have entered an invalid serial number, of which you will be informed by a message).
 - 6.1. Detector type will be displayed.
 - 6.2. A new name of the zone to which the detector is to be assigned will be displayed. You can change the name.
 - 6.3. In the “Zone” field, select the number of the zone to which you want to assign the detector (if you have not done this before or if you want to change the previously selected number).
7. Click on the “OK” button (you can click on the “Quit” button to cancel adding a new detector or on the “Next” button to proceed to adding a next wireless detector). The “New wireless dev.” window will close.
8. Click on the “Write” button to write the new wireless detector data to the controller (these data will not be written after clicking on the  button in the main menu).

LCD keypad

You can add the MICRA (433 MHz) wireless detectors in the service mode by means of the NEW DEVICE function (SERVICE MODE ►2. HARDWARE ►1. KPDS. & EXPS. ►3. WIRELESS DEV. ►1. NEW DEVICE).

1. Start the NEW DEVICE function.
2. When the “Serial number” is displayed, enter the serial number of the detector being added.
3. Press .
4. When the “Open device tamper” command is displayed, open the detector tamper switch.
5. When the type and serial number of the detector will be displayed, press  (if nothing happens, you might have entered a wrong serial number – press  to quit the function).
6. Use the  and  keys to select the zone to which you want to assign the detector.
7. Press .
8. The new name of the zone to which the detector has been assigned will be displayed. You can change that name.
9. Press .
10. The “Presence control” option will be displayed. By default, the option is enabled (the  symbol is displayed). If you want to disable the option, press any number key (the  symbol will be displayed).
11. Press .

5.18.2 Removing MICRA (433 MHz) wireless detectors





DLOADX program

You can remove the MICRA (433 MHz) wireless detectors in the “VERSA – Structure” window, “Hardware” tab, after clicking on the VERSA-MCU controller name in the list of devices.

1. Click on the “Read” button to read the data related to wireless detectors from the controller.
2. Click on the detector you want to remove.
3. Click on the “Delete” button. The “Confirm” window will open.
4. Click on the “Yes” button. The “Confirm” window will close.
5. Click on the “Write” button to save the changes to the controller.

LCD keypad

You can remove the MICRA (433 MHz) wireless detectors in the service mode by means of the REMOVE DEVICE function (SERVICE MODE ►2. HARDWARE ►1. KPDS. & EXPS. ►3. WIRELESS DEV. ►3. REMOVE DEVICE).

1. Start the REMOVE DEVICE function. List of wireless zones will be displayed.
2. Use the  and  keys to select the zone to which the detector you want to remove is assigned.
3. Press  .
4. When a prompt will be displayed asking you whether to remove the detector (type and serial number of the detector will be displayed), press .

6. Numeration of zones and outputs in the system

6.1 Numeration of zones

6.1.1 Hardwired zones

By default, the mainboard zones have numbers from 27 to 30. You can assign any numbers within the 1 to 30 range to these zones (see the PROGRAMMING manual). If number 0 is assigned, the zone will not be supported.

The zones in expanders are numbered depending on the address which is set in them:

- expander with address 12 (0Ch) – numbers from 7 to 14,
- expander with address 13 (0Dh) – numbers from 15 to 22,
- expander with address 14 (0Eh) – numbers from 23 to 30.



If a mainboard zone number coincides with a wireless zone number, the mainboard zone will not be supported.

If an expander zone number coincides with a mainboard zone number or a wireless zone number, the expander zone will not be supported.

6.1.2 Wireless zones

The numbers of wireless zones are defined when adding the wireless devices. You can select any zone number which is not occupied by another wireless device.

6.2 Numeration of outputs

The control panel supports outputs having numbers from 1 to 12. The numbers of hardwired and wireless outputs may coincide. The control panel will support them simultaneously.

6.2.1 Hardwired outputs

The hardwired outputs are assigned numbers automatically:

- the outputs on control panel main board have numbers from 1 to 5,
- the outputs in expander have numbers from 5 to 12.

6.2.2 Wireless outputs

The numbers of wireless outputs are defined when adding the wireless devices. The wireless output number is identical to that of the wireless zone. This means that the wireless outputs may be assigned numbers from 1 to 30, though **the control panel does not support the outputs having numbers from 13 to 30.**

7. Specifications

7.1 Control panel

Supply voltage	18 VAC \pm 15%, 50-60 Hz
Recommended transformer	40 VA
Standby current consumption	150 mA
Maximum current consumption	300 mA
Standby current consumption from battery	130 mA
Maximum current consumption from battery	430 mA
Battery failure voltage threshold	11 V \pm 10%
Battery cut-off voltage	10.5 V \pm 10%
Battery charging current.....	800 mA
Power supply output current	2 A
Power supply output voltage.....	12 VDC \pm 15%
Power supply output voltage range.....	10.5 V...14 VDC
High-current programmable outputs	1100 mA / 12 VDC
Low-current programmable outputs	50 mA / 12 VDC
Relay programmable output.....	1000 mA / 30 VDC
KPD output	500 mA / 12 VDC
AUX output	500 mA / 12 VDC
+VR output.....	200 mA / 12 VDC
Hardwired programmable zones	4
Maximum number of programmable zones.....	30
Hardwired programmable outputs.....	5
Maximum number of programmable outputs	12
Power supply outputs	3
Communication buses	1
Keypads.....	up to 6
Partitions.....	2
Telephone numbers for messaging	8
Voice messages	16

Text messages.....	64
Email addresses for messaging	8
Users.....	30
Timers	4
Event log	2047
Security grade according to EN50131	Grade 2
Environmental class according to EN50130-5	II
Operating temperature range.....	-10...+55°C
Maximum humidity	93±3%
Electronics board dimensions	173 x 105 mm
Enclosure dimensions.....	266 x 286 x 100 mm
Weight (incl. enclosure and accessories).....	1250 g

7.2 VERSA-LCD keypad

Supply voltage	12 VDC ±15%
Standby current consumption	VERSA-LCD-GR.....36 mA
	VERSA-LCD-BL.....40 mA
Maximum current consumption	VERSA-LCD-GR.....110 mA
	VERSA-LCD-BL.....130 mA
Environmental class according to EN50130-5	II
Operating temperature range.....	-10...+55°C
Maximum humidity	93±3%
Enclosure dimensions.....	114.5 x 95 x 22.5 mm
Weight.....	123 g

7.3 VERSA-LCDM keypad

Supply voltage	12 VDC ±15%
Standby current consumption	50 mA
Maximum current consumption	60 mA
Security grade according to EN50131	Grade 2
Environmental class according to EN50130-5	II
Operating temperature range.....	-10...+55°C
Maximum humidity	93±3%
Enclosure dimensions.....	139 x 124 x 22 mm
Weight.....	236 g

7.4 VERSA-LCDR keypad

Supply voltage	12 VDC ±15%
Standby current consumption	30 mA
Maximum current consumption	65 mA
Security grade according to EN50131	Grade 2
Environmental class according to EN50130-5	II
Operating temperature range.....	-10...+55°C
Maximum humidity	93±3%
Enclosure dimensions.....	139 x 124 x 22 mm
Weight.....	240 g

7.5 VERSA-LED keypad

Supply voltage	12 VDC ±15%
Standby current consumption	VERSA-LED-GR 33 mA
	VERSA-LED-BL 40 mA
Maximum current consumption	VERSA-LED-GR 110 mA
	VERSA-LED-BL 120 mA
Environmental class according to EN50130-5	II
Operating temperature range.....	-10...+55°C
Maximum humidity	93±3%
Enclosure dimensions.....	114.5 x 95 x 22.5 mm
Weight.....	97 g

8. Manual update history

Manual version	Introduced changes
09/21	<ul style="list-style-type: none"> Information on INT-TSG2 and INT-TSH2 keypads have been added.

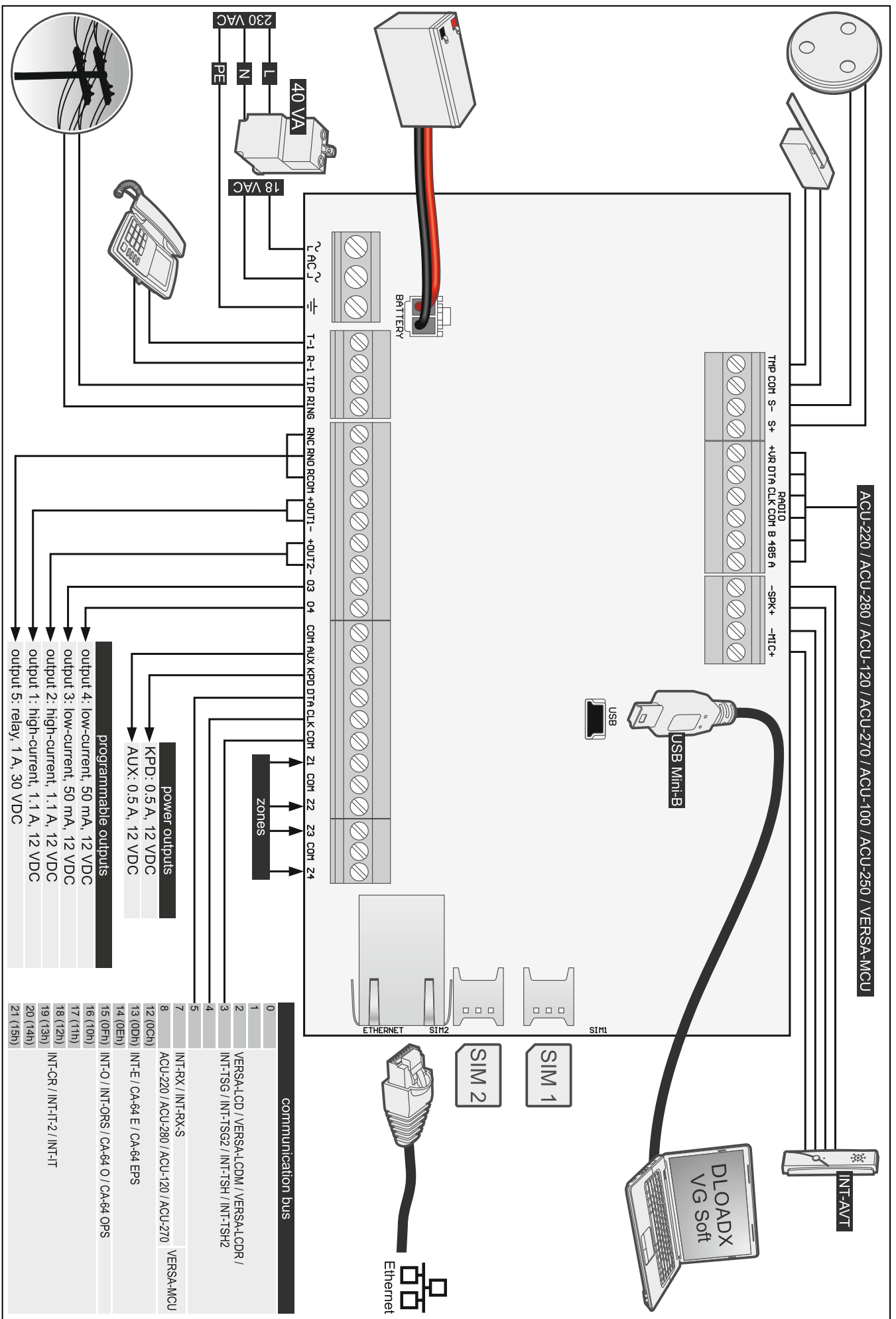

- programmable outputs**
- output 4: low-current, 50 mA, 12 VDC
 - output 3: low-current, 50 mA, 12 VDC
 - output 2: high-current, 1.1 A, 12 VDC
 - output 1: high-current, 1.1 A, 12 VDC
 - output 5: relay, 1 A, 30 VDC

- power outputs**
- KPD: 0.5 A, 12 VDC
 - AUX: 0.5 A, 12 VDC

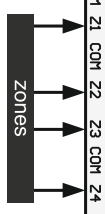

communication bus	
0	
1	
2	VERSA-CD / VERSA-CDM / VERSA-CDR /
3	INT-TSG / INT-TSG2 / INT-TSH / INT-TSH2
4	
5	
7	INT-RX / INT-RX-S
8	ACU-220 / ACU-280 / ACU-120 / ACU-270
12	(0Ch) VERSA-MCU
13	(0Dh) INT-E / CA-64 E / CA-64 EPS
14	(0Eh) INT-O / INT-ORS / CA-64 O / CA-64 OPS
15	(0Fh)
16	(10h)
17	(11h)
18	(12h)
19	(13h) INT-CR / INT-IT-2 / INT-IT
20	(14h)
21	(15h)