



BE WAVE system controller

# Smart HUB Plus Smart HUB Smart HUB Plus LV

EN

Firmware version 1.1

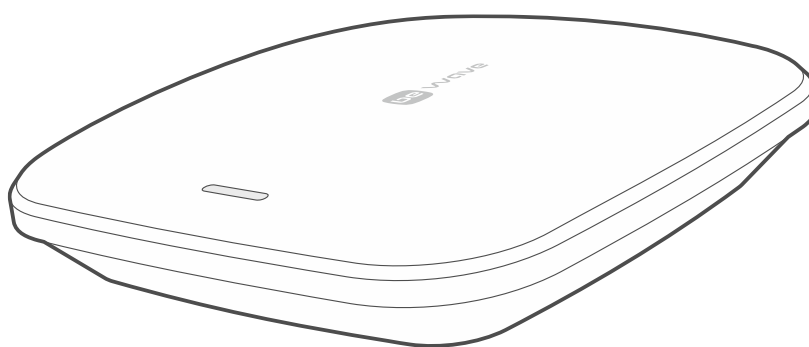







CE

smart\_hub\_en 03/25

## IMPORTANT



Changes, modifications or repairs not authorized by the manufacturer shall void your rights under the warranty.

The symbols on the rating plate of the device indicate:

-  The device meets the requirements of the applicable EU directives.
-  The device must not be disposed of with other municipal waste. It should be disposed of in accordance with the existing rules for environment protection (the device was placed on the market after 13 August 2005).
-  Protection class II (protective insulation).
-  The device is designed for indoor installation.
-  Alternating current (AC).
-  Direct current (DC).
-  Prior to installation, please read carefully the manual.

**Hereby, SATEL sp. z o.o. declares that the radio equipment type Smart HUB Plus / Smart HUB / Smart HUB Plus LV is in compliance with Directive 2014/53/EU. The full text of the EU declaration of conformity is available at the following internet address:  
[www.satel.pl/ce](http://www.satel.pl/ce)**

### Signs in this manual

-  Caution – information on the safety of users, devices, etc.
-  Note – suggestion or additional information.

## CONTENTS

1. Introduction .....	6
2. Smart HUB Plus / Smart HUB features / Smart HUB Plus LV .....	6
3. BE WAVE wireless devices .....	7
3.1 Smart Keypad (AKP-200) .....	7
3.2 Motion Detector (APD-200) .....	7
3.3 Motion Detector Pet (APD-200 Pet) .....	8
3.4 Motion Detector Cam (APCAM-200) .....	9
3.5 Motion Detector Plus (APMD-250) .....	10
3.6 Outdoor Motion Detector (AOD-210) .....	11
3.7 Curtain Detector (ACD-220) .....	12
3.8 Outdoor Curtain Detector (AOCD-260) .....	13
3.9 Glass Break Detector (AGD-200) .....	13
3.10 Multipurpose Detector (AXD-200) .....	14
3.10.1 Shock detector .....	14
3.10.2 Opening detector .....	14
3.10.3 Shock and opening detector .....	14
3.10.4 Flood detector .....	14
3.10.5 Temperature sensor .....	14
3.10.6 Roller shutter detector .....	14
3.11 Opening Detector (AXD-200 Lite) .....	14
3.12 Flood Detector (AFD-200) .....	15
3.13 Fire Detector Plus (ASD-200) .....	15
3.14 Fire Detector Pro (ASD-250) .....	15
3.15 Carbon Monoxide Detector (ACMD-200) .....	15
3.16 Outdoor Dusk Detector (ADD-200) .....	16
3.17 Multi Sensor (ATPH-200) .....	16
3.18 Outdoor Siren (ASP-200) .....	16
3.19 Indoor Siren (ASP-215) .....	17
3.20 Mini Multi Extender (ACX-210) .....	17
3.21 Multi Extender (ACX-220) .....	17
3.22 Smart Dimmer (ADC-200) .....	17
3.23 Smart RGBW LED Driver (ARC-200) .....	18
3.24 Smart Blinds (ARSC-200) .....	18
3.25 Smart Thermostat (ART-210) .....	19
3.26 Smart Plug (ASW-200) .....	19
3.27 Smart 2-CH Relay (ASW-210) .....	19
3.28 Smart Keyfob (APT-210) .....	20
3.29 Smart Switch Controller (ATX-200) .....	20
3.30 Smart Button (APB-210) .....	20
3.31 Smart Repeater (ARU-200) .....	20
4. Installation .....	21
4.1 Installing the Smart HUB Plus / Smart HUB controller .....	21
4.1.1 Description of the Smart HUB Plus / Smart HUB controller .....	22
4.1.2 Installation tips for the Smart HUB Plus / Smart HUB controller .....	23
4.1.3 Mounting the Smart HUB Plus / Smart HUB controller .....	24
4.2 Installing the Smart HUB Plus LV controller .....	29

- 4.2.1 Description of the Smart HUB Plus LV controller .....29
- 4.2.2 Installation tips for the Smart HUB Plus LV controller .....30
- 4.2.3 Mounting the Smart HUB Plus LV controller .....31
- 4.3 Adding the controller to the Be Wave app .....35
- 4.4 Adding a BE WAVE device to the system .....39
  - 4.4.1 Adding the first BE WAVE device .....39
  - 4.4.2 Adding another BE WAVE device .....41
- 4.5 Installing BE WAVE devices.....41
  - 4.5.1 Installing the Smart Keypad .....42
    - Description of the Smart Keypad .....42
    - Installation tips for the Smart Keypad .....42
    - Mounting the Smart Keypad.....42
  - 4.5.2 Installing the Motion Detector, Motion Detector Pet and Motion Detector Plus...44
    - Installation tips for the Motion Detector, Motion Detector Pet and Motion Detector Plus .....44
    - Mounting the Motion Detector, Motion Detector Pet and Motion Detector Plus ..45
  - 4.5.3 Installing the Motion Detector Cam .....48
    - Installation tips for the Motion Detector Cam .....48
    - Description of the Motion Detector Cam .....49
    - Mounting the Motion Detector Cam .....50
  - 4.5.4 Installing the Outdoor Motion Detector .....54
    - Installation tips for the Outdoor Motion Detector .....54
    - Mounting the Outdoor Motion Detector .....55
  - 4.5.5 Installing the Curtain Detector .....59
    - Installation tips for the Curtain Detector .....59
    - Mounting the Curtain Detector .....59
  - 4.5.6 Installing the Outdoor Curtain Detector .....61
    - Installation tips for the Outdoor Curtain Detector .....61
    - Mounting the Outdoor Curtain Detector .....61
  - 4.5.7 Installing the Glass Break Detector.....63
    - Installation tips for the Glass Break Detector .....63
    - Mounting the Glass Break Detector .....63
  - 4.5.8 Installing the Multipurpose Detector.....65
    - Description of the Multipurpose Detector .....65
    - Installation tips for the Multipurpose Detector .....65
    - Mounting the Multipurpose Detector .....66
  - 4.5.9 Installing the Opening Detector.....69
    - Description of the Opening Detector .....69
    - Installation tips for the Opening Detector .....69
    - Mounting the Opening Detector .....70
  - 4.5.10 Installing the Flood Detector .....72
    - Installation tips for the Flood Detector.....72
    - Start-up the Flood Detector.....72
  - 4.5.11 Installing the Fire Detector Plus / Fire Detector Pro .....73
    - Installation tips for the Fire Detector Plus / Fire Detector Pro .....73
    - Mounting the Fire Detector Plus / Fire Detector Pro .....74
  - 4.5.12 Installing the Carbon Monoxide Detector .....75
    - Installation tips for the Carbon Monoxide Detector .....75
    - Mounting the Carbon Monoxide Detector.....75
  - 4.5.13 Installing the Outdoor Dusk Detector .....77
    - Installation tips for the Outdoor Dusk Detector.....77
    - Mounting the Outdoor Dusk Detector.....77

4.5.14	Installing the Multi Sensor.....	78
	Installation tips for the Multi Sensor.....	78
	Mounting the Multi Sensor.....	78
4.5.15	Installing the Outdoor Siren.....	80
	Installation tips for the Outdoor Siren.....	80
	Mounting the Outdoor Siren.....	80
4.5.16	Installing the Indoor Siren.....	81
	Installation tips for the Indoor Siren.....	81
	Mounting the Indoor Siren.....	81
4.5.17	Installing the Mini Multi Extender.....	82
	Description of the Mini Multi Extender.....	83
	Installation tips for the Mini Multi Extender.....	83
	Mounting the Mini Multi Extender.....	83
4.5.18	Installing the Multi Extender.....	85
	Description of the Multi Extender.....	86
	Installation tips for the Multi Extender.....	87
	Mounting the Multi Extender.....	87
4.5.19	Installing the Smart Dimmer.....	89
	Description of the Smart Dimmer.....	90
	Installation tips for the Smart Dimmer.....	90
	Mounting the Smart Dimmer.....	91
4.5.20	Installing the Smart RGBW LED Driver.....	91
	Description of the Smart RGBW LED Driver.....	92
	Installation tips for the Smart RGBW LED Driver.....	92
	Mounting the Smart RGBW LED Driver.....	93
4.5.21	Installing the Smart Blinds.....	95
	Description of the Smart Blinds.....	95
	Installation tips for the Smart Blinds.....	96
	Mounting the Smart Blinds.....	96
4.5.22	Installing the Smart Thermostat.....	97
	Installation tips for the Smart Thermostat.....	97
	Mounting the Smart Thermostat.....	98
4.5.23	Installing the Smart Plug.....	102
	Installation tips for the Smart Plug.....	103
	Initiating the Smart Plug.....	103
4.5.24	Installing the Smart 2-CH Relay.....	103
	Description of the Smart 2-CH Relay.....	103
	Installation tips for the Smart 2-CH Relay.....	104
	Mounting the Smart 2-CH Relay.....	105
4.5.25	Installing the Smart Switch Controller.....	106
	Description of the Smart Switch Controller.....	106
	Installation tips for the Smart Switch Controller.....	106
	Mounting the Smart Switch Controller.....	106
4.5.26	Installing the Smart Button.....	107
	Installation tips for the Smart Button.....	107
	Mounting the Smart Button.....	108
4.5.27	Installing the Smart Repeater.....	108
	Description of the Smart Repeater.....	109
	Installation tips for the Smart Repeater.....	109
	Mounting the Smart Repeater.....	110
4.6	Adding the Smart Keyfob to the system.....	112
5.	Testing.....	112

5.1	Enabling the diagnostic mode .....	113
6.	Maintenance .....	113
6.1	Firmware update .....	113
6.2	Replacing the (rechargeable) battery .....	113
6.2.1	Replacing the rechargeable battery in the Smart HUB Plus / Smart HUB / Smart HUB Plus LV controller.....	113
6.2.2	Replacing the battery in the BE WAVE device.....	114
	Replacing the battery in the Outdoor Siren .....	114
	Opening the Smart Keyfob enclosure .....	115
6.3	Cleaning the Fire Detector Plus / Fire Detector Pro smoke chamber .....	115
6.4	Restoring the controller factory settings .....	117
6.4.1	Restoring the factory settings from the Be Wave app .....	117
6.4.2	Hardware factory restore.....	117
6.5	Turning off the Smart HUB Plus / Smart HUB controller .....	117
6.6	Turning off the Smart HUB Plus LV controller .....	117
7.	Using the Smart Keypad.....	118
7.1	LED indicators .....	118
7.2	Keys .....	119
7.3	Sound signaling.....	119
7.3.1	Beeps generated when keypad is in use .....	119
7.3.2	Event signaling.....	119
7.4	Operating modes of battery-powered keypad .....	119
8.	Using the Smart Keyfob.....	120
9.	Manual control of the devices .....	121
9.1	Manual control of the Smart Thermostat .....	121
9.1.1	LED display .....	121
	Symbols on the display .....	121
	Messages on the display.....	121
	Rotating the temperature / messages on the display by 180° .....	122
9.1.2	Knob .....	122
9.1.3	Changing the operating mode manually .....	122
9.1.4	Temporarily setting other temperature .....	122
9.1.5	Changing the temperature setting for the selected operating mode.....	123
9.2	Manual control of the Smart Plug .....	123
9.2.1	LED indicator .....	123
9.2.2	Button.....	123
10.	Specifications .....	124
10.1	Smart HUB Plus / Smart HUB .....	124
10.2	Smart HUB Plus LV .....	124
10.3	Smart Keypad (AKP-200) .....	125
10.4	Motion Detector (APD-200) .....	125
10.5	Motion Detector Pet (APD-200 Pet) .....	126
10.6	Motion Detector Cam (APCAM-200) .....	127
10.7	Motion Detector Plus (APMD-250) .....	127
10.8	Outdoor Motion Detector (AOD-210).....	128
10.9	Curtain Detector (ACD-220) .....	129
10.10	Outdoor Curtain Detector (AOCD-260) .....	129
10.11	Glass Break Detector (AGD-200).....	130

10.12	Multipurpose Detector (AXD-200)	130
	Opening detector / Shock and opening detector	131
	Shock detector / Shock and opening detector	131
10.13	Opening Detector (AXD-200 Lite)	131
10.14	Flood Detector (AFD-200)	132
10.15	Fire Detector Plus (ASD-200)	132
10.16	Fire Detector Pro (ASD-250)	133
10.17	Carbon Monoxide Detector (ACMD-200)	134
10.18	Outdoor Dusk Detector (ADD-200)	134
10.19	Multi Sensor (ATPH-200)	135
10.20	Outdoor Siren (ASP-200)	135
10.21	Indoor Siren (ASP-215)	136
10.22	Mini Multi Extender (ACX-210)	136
10.23	Multi Extender (ACX-220)	137
10.24	Smart Dimmer (ADC-200)	137
10.25	Smart RGBW LED Driver (ARC-200)	138
10.26	Smart Blinds (ARSC-200)	138
10.27	Smart Thermostat (ART-210)	139
10.28	Smart Plug (ASW-200)	139
10.29	Smart 2-CH Relay (ASW-210)	140
10.30	Smart Keyfob (APT-210)	140
10.31	Smart Switch Controller (ATX-200)	141
10.32	Smart Button (APB-210)	141
10.33	Smart Repeater (ARU-200)	141

## 1. Introduction

---

This manual will help you install the Smart HUB Plus / Smart HUB / Smart HUB Plus LV controller and other devices in the BE WAVE system. The BE WAVE system combines building automation functions and security functions which protect against burglary, fire or other emergencies. You can control the system using the Be Wave mobile app.

The manual applies to the controller with electronics version:

Smart HUB / Smart HUB Plus: 1.5,

Smart HUB Plus LV: 1.2.

## 2. Smart HUB Plus / Smart HUB features / Smart HUB Plus LV

---

- Support for up to 128 BE WAVE wireless devices:
  - operation in the 868 MHz frequency band,
  - AES encrypted two-way radio communication,
  - transmission channel diversity – 4 channels for automatic selection of the one that will enable transmission without interference with other signals,
  - additional transmission channel to receive images from the Motion Detector Cam.
- Capability to assign devices to 50 rooms.
- Up to 50 users.
- Be Wave mobile app to manage the system:
  - communication via the local network or establishing connection through the Internet using the SATEL server,
  - system programming,
  - system control,
  - system diagnostics,
  - valid for installation on up to 5 different mobile devices of the user.
- Capability to arm the system fully or partially.
- Up to 100 scenes and routines:
  - scenes for easier control.
  - routines for automated system operation.
- 8000 event log entries.
- Event notification types:
  - push,
  - SMS [Smart HUB Plus / Smart HUB Plus LV],
  - CLIP [Smart HUB Plus / Smart HUB Plus LV].
- Reporting:
  - reporting events to two monitoring stations,
  - support for Contact ID, SIA and Bold Manitou communication formats,
  - data transmission via Ethernet or cellular network [Smart HUB Plus / Smart HUB Plus LV],
  - Dual Path Reporting compliant with EN 50136 [Smart HUB Plus / Smart HUB Plus LV].
- Capability to update firmware of the controller and the devices in the system.
- Built-in Ethernet (LAN) port.

- Built-in Wi-Fi:
  - operating in the 2.4 and 5 GHz bands,
  - IEEE 80.11 b/g/n (2,4 GHz) / IEEE 802.11 a/n (5 GHz) standards.
- Built-in cellular telephone [Smart HUB Plus / Smart HUB Plus LV]:
  - operating in the 2G and 4G networks,
  - dual SIM support.
- LED indicator.
- Powered by:
  - 230 VAC [Smart HUB Plus / Smart HUB],
  - 9...28 VDC [Smart HUB Plus LV].
- Backup battery.
- Battery charging circuit.
- Battery status control and low battery disconnect system.
- Tamper protection against enclosure opening and removal from mounting surface.

### **3. BE WAVE wireless devices**

---

- Operation in the 868 MHz frequency band.
- AES encrypted two-way radio communication.
- Transmission channel diversity – 4 channels for automatic selection of the one that will enable transmission without interference with other signals.
- Remote settings programming.
- Remote firmware update (not applicable to Fire Detector Pro).

#### **3.1 Smart Keypad (AKP-200)**

---

It controls the BE WAVE system.

- Touch keys with backlight.
- 2 function keys.
- 4 LED indicators.
- Built-in sounder.
- Powered by:
  - two LR6 AA 1.5 V batteries (required),
  - SATEL APS-055 power supply (optional).
- Battery status control.

#### **3.2 Motion Detector (APD-200)**

---

It uses infrared to detect motion.

- Maximum coverage area: 15 m x 24 m, 90° (see figure below).
- Digital motion detection algorithm.
- Digital temperature compensation.
- Capability to enable / disable the creep zone protection.
- Built-in temperature sensor (measuring range: -10 °C...+55°C).
- LED indicators.

- Supervision of motion detection system.
- Powered by CR123A 3 V battery.
- Battery status control.
- Tamper protection against enclosure opening and removal from mounting surface.

#### Motion Detector (APD-200)

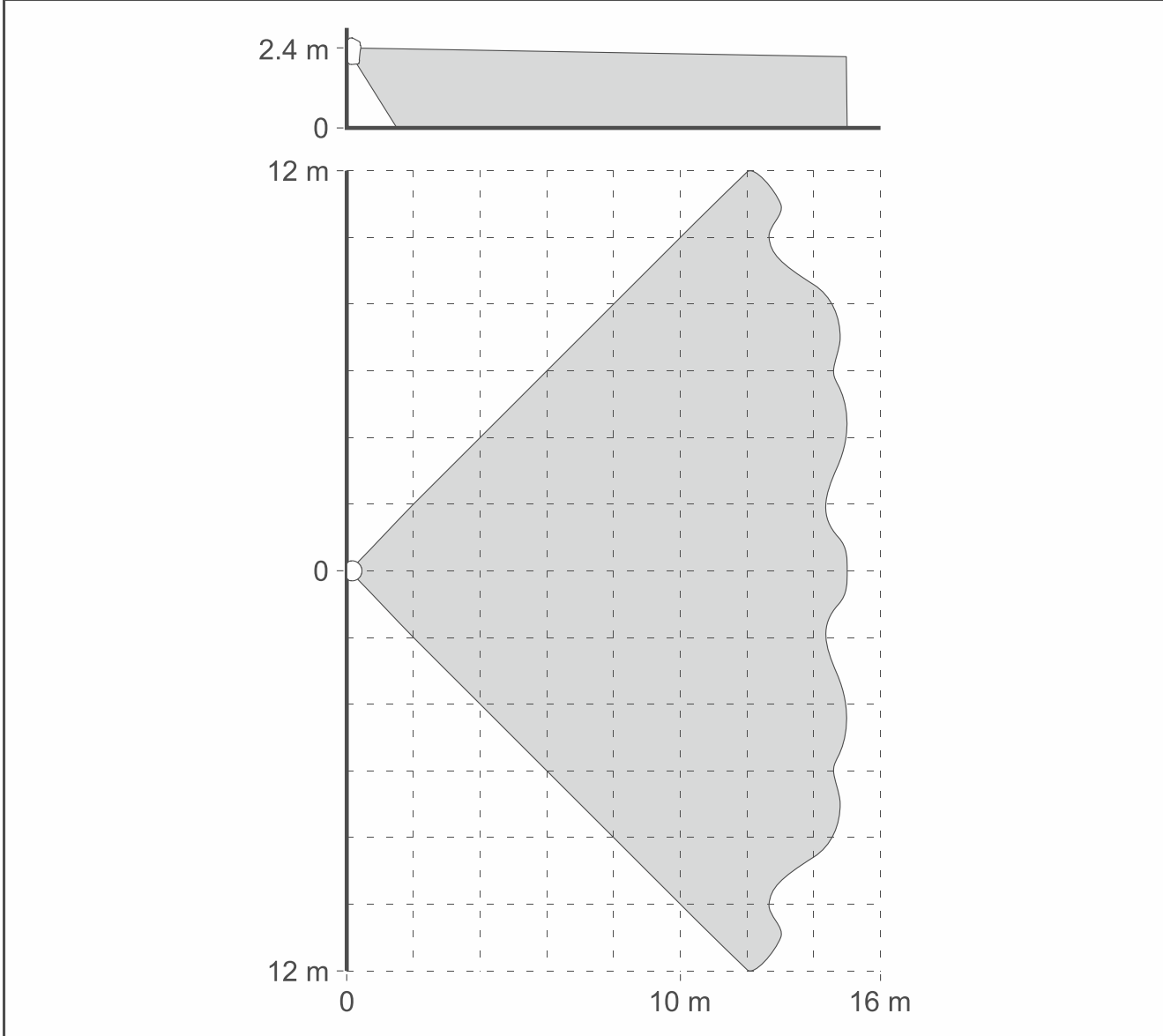

### 3.3 Motion Detector Pet (APD-200 Pet)

It uses infrared to detect motion. It ignores moving pets up to 20 kilos.

- Maximum coverage area: 14 m x 16 m, 83° (see figure below).
- Digital motion detection algorithm.
- Digital temperature compensation.
- Built-in temperature sensor (measuring range: -10 °C...+55°C).
- LED indicators.
- Supervision of motion detection system.
- Powered by CR123A 3 V battery.
- Battery status control.

- Tamper protection against enclosure opening and removal from mounting surface.

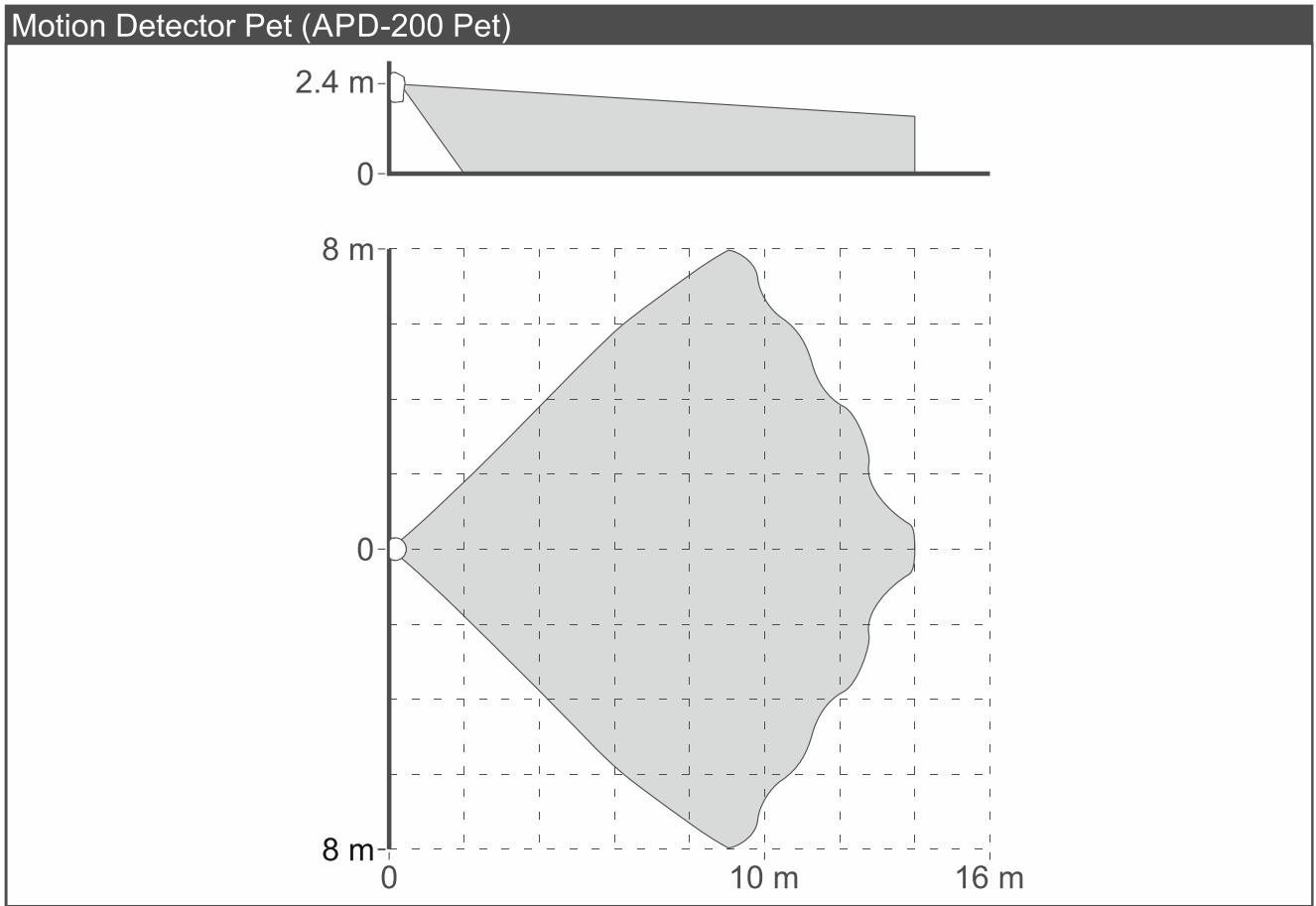

### 3.4 Motion Detector Cam (APCAM-200)

It uses infrared to detect motion. It has a camera that sends photos to the app in case of alarm or on user's request.

- Maximum coverage area: 15 m x 24 m, 90° (see figure below).
- Digital motion detection algorithm.
- Digital temperature compensation.
- Option to enable / disable the creep zone protection.
- Camera for alarm verification:
  - a series of 3 photos when alarm occurs,
  - switching to black and white mode in poor lighting,
  - infrared illumination in poor lighting,
  - capability to take photos on request,
  - image size: 640x480 pixels.
- Additional transmission channel in the 868 MHz frequency band for the purpose of sending photos.
- Built-in temperature sensor (measuring range: -10 °C...+55°C).
- LED indicators.
- Supervision of motion detection system.
- Powered by:
  - CR123A 3 V battery (required),
  - SATEL APS-055 power supply (optional).

- Battery status control.
- Tamper protection against enclosure opening and removal from mounting surface.

#### Motion Detector Cam (APCAM-200)

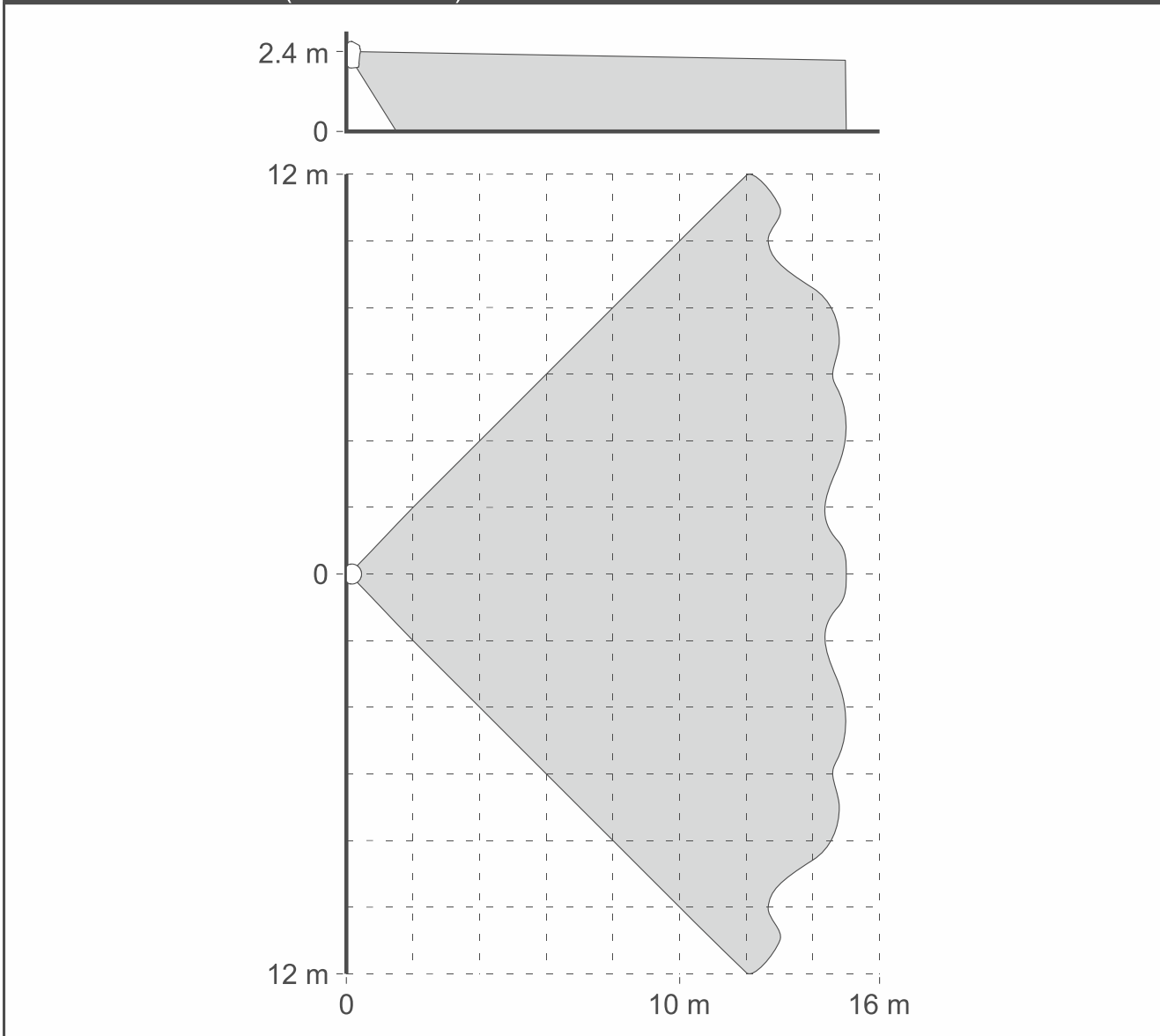

### 3.5 Motion Detector Plus (APMD-250)

It uses infrared and microwaves to detect motion.

- Maximum coverage area: 15 m x 24 m, 90° (see figure below).
- Digital motion detection algorithm for both sensors.
- Digital temperature compensation.
- Capability to enable / disable the creep zone protection.
- Built-in temperature sensor (measuring range: -10 °C...+55°C).
- LED indicators.
- Supervision of motion detection system.
- Powered by CR123A 3 V battery.
- Battery status control.
- Tamper protection against enclosure opening and removal from mounting surface.

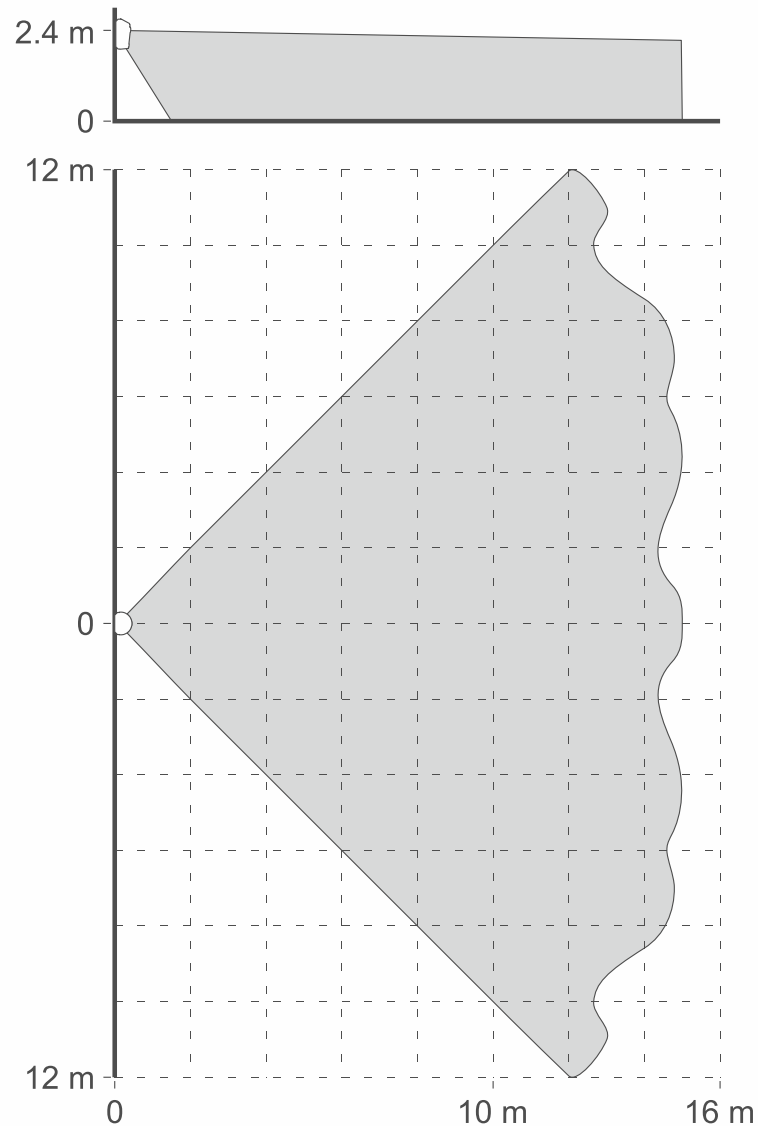
**Motion Detector Plus (APMD-250)****3.6 Outdoor Motion Detector (AOD-210)**

It uses infrared and microwaves to detect motion. It ignores moving pets up to 20 kilos. It is designed for outdoor installation.

- Maximum coverage area: 16 m x 16 m, 90° (see figure below).
- Digital motion detection algorithm for both sensors.
- Digital temperature compensation.
- Immunity to false alarms caused by objects moving but not changing their position (e.g. branches of trees).
- Creep zone protection.
- Built-in dusk sensor (measuring range: 2 lx...250 lx).
- Built-in temperature sensor (measuring range: -40 °C...+55°C).
- LED indicators.
- Supervision of motion detection system.
- Powered by CR123A 3 V battery.
- Battery status control.

- Tamper protection against enclosure opening and removal from mounting surface.
- Weatherproof enclosure.

### Outdoor Motion Detector (AOD-210)

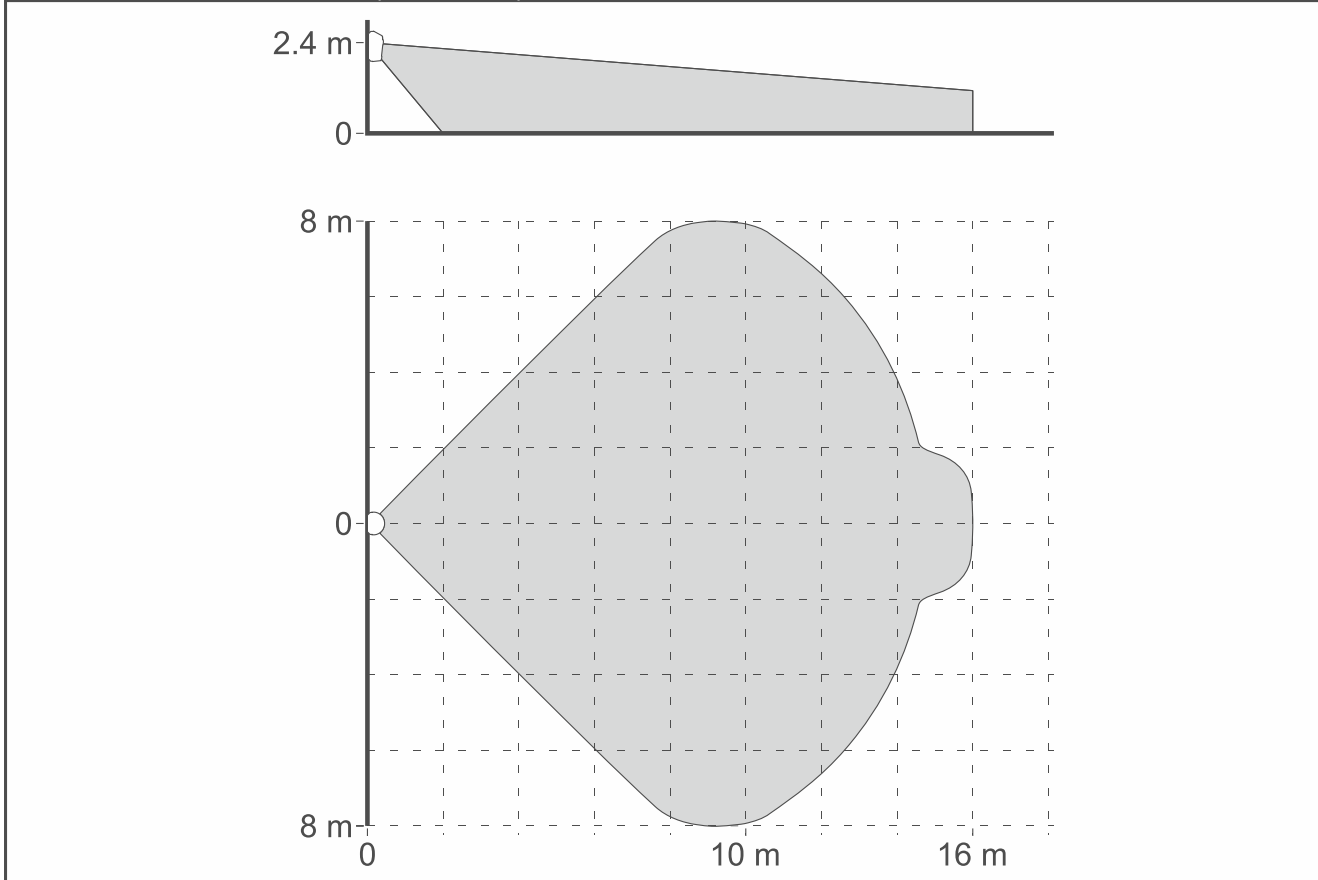

### 3.7 Curtain Detector (ACD-220)

It uses infrared to detect motion in an area shaped like a curtain.

- Maximum coverage area: 5 m x 1 m, 15° (see figure below).
- Digital motion detection algorithm.
- Digital temperature compensation.
- Built-in temperature sensor (measuring range: -10 °C...+55°C).
- LED indicators.
- Supervision of motion detection system.
- Powered by CR123A 3 V battery.
- Battery status control.
- Tamper protection against enclosure opening and removal from mounting surface.

### Curtain Detector (ACD-220)

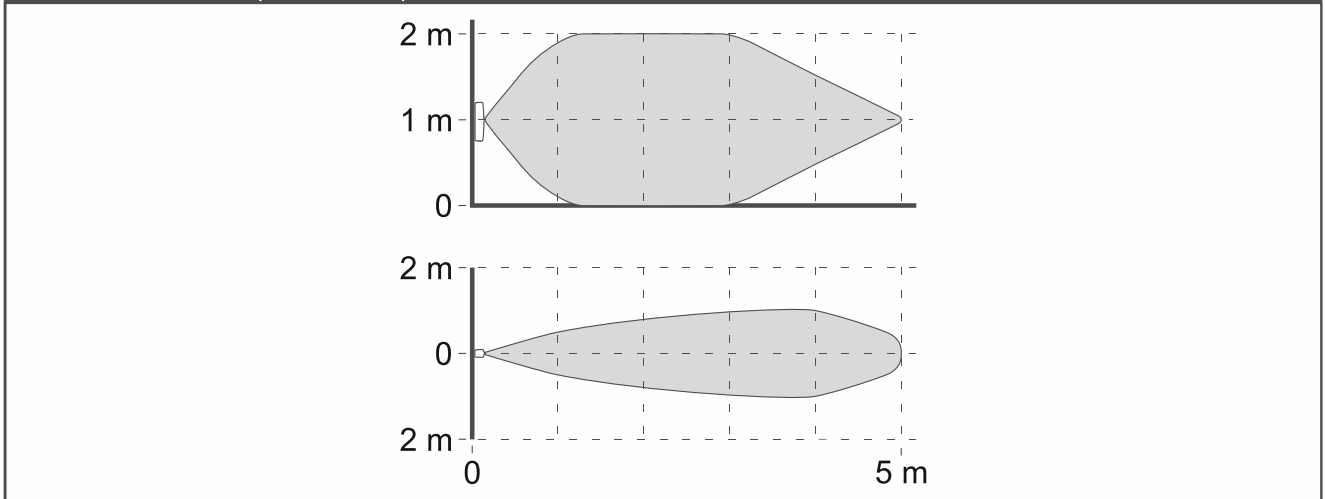

### 3.8 Outdoor Curtain Detector (AOCD-260)

It uses infrared and microwaves to detect motion in an area shaped like a curtain. It is designed for outdoor installation.

- Maximum coverage area: 10 m x 0.6 m, 6° (see figure below).
- Digital motion detection algorithm for both sensors.
- Digital temperature compensation.
- Built-in temperature sensor (measuring range: -40 °C...+55°C).
- LED indicator.
- Supervision of motion detection system.
- Powered by CR123A 3 V battery.
- Battery status control.
- Tamper protection against enclosure opening and removal from mounting surface.
- Weatherproof enclosure.

### Outdoor Curtain Detector (AOCD-260)

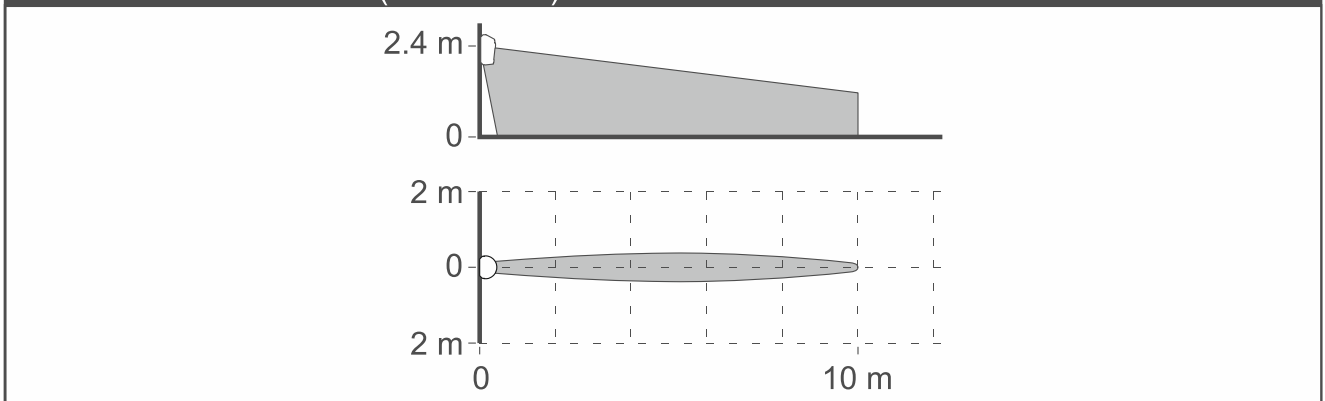

### 3.9 Glass Break Detector (AGD-200)

It detects a glass break.

- Advanced, two-factor sound analysis (the sound of breaking glass must be preceded by a thump).
- Built-in temperature sensor (measuring range: -10°C...+55°C).
- LED indicator.

- Powered by CR123A 3 V battery.
- Battery status control.
- Tamper protection against enclosure opening and removal from mounting surface.

### 3.10 Multipurpose Detector (AXD-200)

---

It can be used as:

- Shock detector
- Opening detector
- Shock and opening detector
- Flood detector
- Temperature sensor
- Roller shutter detector
- Built-in temperature sensor (measuring range: -10 °C...+55°C).
- LED indicator.
- Powered by CR123A 3 V battery.
- Battery status control.
- Tamper protection against enclosure opening and removal from mounting surface.
- A magnet for surface mounting and a magnet for flush mounting are provided (a magnet is used when the detector operates as *Opening detector* or *Shock and opening detector*).

#### 3.10.1 Shock detector

It detects shocks accompanying attempts to force open a door or window.

#### 3.10.2 Opening detector

It detects the opening of a door or window. You can connect a wired NC detector (e.g. a wired opening detector) to the detector. The built-in opening sensor can be disabled.

#### 3.10.3 Shock and opening detector

It detects shocks accompanying attempts to force open a door or window. It also detects the opening of a door or window. You can connect a wired NC detector to it (e.g. a wired opening detector). The built-in opening sensor can be disabled.

#### 3.10.4 Flood detector

It detects indoor water flooding.



You need to buy the FPX-1 probe by SATEL.

#### 3.10.5 Temperature sensor

It measures the air temperature.

#### 3.10.6 Roller shutter detector

It detects the opening of a door or window. You can connect to it a wired roller shutter detector and a wired NC detector (e.g. a wired opening detector).

### 3.11 Opening Detector (AXD-200 Lite)

---

It detects the opening of a door or window. You can connect a wired NC detector to it (e.g. a wired opening detector). The built-in opening sensor can be disabled.

- LED indicator.

- Powered by CR123A 3 V battery.
- Battery status control.
- Tamper protection against enclosure opening and removal from mounting surface.
- A magnet for surface mounting and a magnet for flush mounting provided.

### 3.12 Flood Detector (AFD-200)

---

It detects indoor water flooding.

- Built-in temperature sensor (measuring range: -10 °C...+55°C).
- Detection of detector overturn.
- LED indicator.
- Built-in sounder (alarm and overturn signaling).
- Powered by CR123A 3 V battery.
- Battery status control.

### 3.13 Fire Detector Plus (ASD-200)

---

It detects the presence of smoke or a rapid temperature rise (early signs of fire).

- Detection of dirty smoke chamber.
- Temperature measurement range: 0°C...+55°C.
- LED indicator.
- Built-in sounder (alarm and low battery signaling).
- Detector test / reset button.
- Powered by CR123A 3 V battery.
- Battery status control.
- Tamper protection against cover removal.



*The detector is not a construction product as defined in Regulation (EU) No 305/2011 of the European Parliament and of the Council of 9 March 2011.*

### 3.14 Fire Detector Pro (ASD-250)

---

It detects the presence of smoke (early sign of fire). It meets the EN 14604 requirements.

- Detection of dirty smoke chamber.
- LED indicator.
- Built-in sounder (alarm and low battery signaling).
- Detector test / reset button.
- Powered by CR123A 3 V battery.
- Battery status control.
- Tamper protection against cover removal.

### 3.15 Carbon Monoxide Detector (ACMD-200)

---

It detects hazardous levels of carbon monoxide.

- Digital temperature compensation.
- Built-in temperature sensor (measuring range: 0°C...+55°C).
- LED indicator.

- Built-in sounder (signaling of alarm, gas sensor failure and low battery).
- Detector test / reset button.
- Carbon monoxide sensor supervision.
- Powered by CR123A 3 V battery.
- Battery status control.
- Tamper protection against cover removal.



*The gas sensor reaction to a decrease in the hazardous gas concentration is delayed, hence the restore of alarm can take place even a few minutes after the danger is over.*

*The gas sensor life is up to 10 years.*

### 3.16 Outdoor Dusk Detector (ADD-200)

---

It detects dusk and dawn based on the measurement of light intensity. Designed for outdoor installation.

- Immunity to short and accidental changes of light intensity.
- Built-in temperature sensor (measuring range: -20°C...+55°C).
- LED indicator.
- Powered by CR123A 3 V battery.
- Battery status control.
- Weatherproof enclosure.

### 3.17 Multi Sensor (ATPH-200)

---

It measures temperature, pressure and humidity.

- Temperature sensor:
  - measuring range: -10°C...+55°C,
  - measurement accuracy:  $\pm 0.2^\circ\text{C}$ .
- Barometric pressure sensor:
  - measuring range: 260...1260 hPa,
  - measurement accuracy:  $\pm 0.1$  hPa.
- Humidity sensor:
  - measuring range: 0%RH...93%RH,
  - measurement accuracy:  $\pm 1.5\%$ RH.
- LED indicator.
- Sensors supervision.
- Powered by CR123A 3 V battery.
- Battery status control.
- Tamper protection against enclosure opening and removal from mounting surface.



*If any of the sensors is damaged, the LED indicator is flashing and the detector does not communicate with the controller.*

### 3.18 Outdoor Siren (ASP-200)

---

The alarm siren emits sound and light signals. It is designed for outdoor installation.

- Powered by ER34615 3.6 V battery.

- Battery status control.
- Weatherproofed electronic circuit.
- Tamper protection against enclosure opening and removal from mounting surface.
- Built-in spirit level to facilitate installation.
- High mechanical strength of the enclosure.



*The siren is powered from a 3.6 V lithium thionyl chloride battery. It is a high-current, high-capacity battery. The battery must be replaced as described in the “Replacing the battery in the Outdoor Siren” (p. 114) section.*

### **3.19 Indoor Siren (ASP-215)**

---

The alarm siren emits sound and light signals.

- Built-in temperature sensor (measuring range: -10°C...+55°C).
- Powered by CR123A 3 V battery.
- Battery status control.
- Tamper protection against enclosure opening and removal from mounting surface.
- High mechanical strength of the enclosure.



*The siren signaling is started after a delay of up to 24 seconds.*

### **3.20 Mini Multi Extender (ACX-210)**

---

It makes it possible to use wired detectors in the system and to control wired devices.

- 4 programmable zones:
  - support for NO and NC type detectors,
  - support for Single EOL and Double EOL configuration.
- 4 OC type outputs,
- Powered by 4...24 VDC.
- Mini size for installation inside another device enclosure.

### **3.21 Multi Extender (ACX-220)**

---

It makes it possible to use wired detectors in the system and to control wired devices.

- 4 programmable zones:
  - support for NO and NC type detectors,
  - support for Single EOL and Double EOL configuration.
- 4 relay outputs.
- Powered by 12 VDC.
- Connector for SATEL power supply (e.g. APS-412).
- Tamper protection against cover removal.

### **3.22 Smart Dimmer (ADC-200)**

---

It adjusts the brightness of 230 VAC lighting. It can be used to turn on / turn off / dim down / dim up the lights.

- Supported light sources:
  - incandescent bulbs,

- halogen bulbs,
- LED bulbs,
- light sources powered by an electronic or magnetic transformer.
- Automatic recognition of the connected load.
- Remote control or local control by means of control inputs.
- Stepless adjustment of light brightness.
- Memory of set brightness level.
- 2 control inputs:
  - capability to connect a push-button or a switch,
  - lighting controlled locally,
  - capability to control any device in the system.
- Firmware protection against overload and overheating.
- Powered by 230 VAC.
- Installed in a flush- or surface-mounted junction box with a minimum diameter of 60 mm.

### **3.23 Smart RGBW LED Driver (ARC-200)**

---

It controls the light color and adjusts the brightness of 12...48 VDC LED lighting. It can be used to turn on / turn off / dim down / dim up the lights / change the light color.

- Supported light sources:
  - RGBW LED strip,
  - RGB LED strip,
  - CCT LED strips (cool/warm),
  - single color LED strips,
  - LED bulbs,
  - halogen bulbs.
- Remote control or local control by means of control inputs.
- Stepless adjustment of light brightness.
- Memory of set color and brightness level.
- 2 control inputs:
  - capability to connect a push-button or a switch,
  - lighting controlled locally,
  - capability to control any device in the system.
- Hardware protection against overheating.
- Powered by 12...48 VDC.
- Installed in a flush- or surface-mounted junction box with a minimum diameter of 60 mm.

### **3.24 Smart Blinds (ARSC-200)**

---

It opens and closes roller blinds / shutters / window actuators. It controls devices driven by a 230 VAC motor with limit switches.

- Remote control or local control by means of control inputs.
- Automatic detection of blind / shutter travel time.
- Detection of blind / shutter errors (no power, incorrect position, mechanical jam, motor overheating).

- 2 control inputs:
  - capability to connect a double push-button or a roller blind switch,
  - local blind / shutter control,
  - capability to control any device in the system.
- Powered by 230 VAC.
- Installed in a flush- or surface-mounted junction box with a minimum diameter of 60 mm.

### **3.25 Smart Thermostat (ART-210)**

---

It controls the radiator valve and keeps the room temperature at a set level.

- Temperature setting in the range from 5°C to 30°C.
- Several operating modes.
- Remote control or manual control.
- Boost Heat.
- Capability to close the valve manually.
- Anti-scale function.
- Open window detection.
- Anti-freeze protection.
- Child Lock.
- Built-in temperature sensor (measuring range: -10 °C...+55°C).
- LED display for easier control and configuration.
- Capability to rotate the messages on display by 180°.
- Powered by two LR6 AA 1.5 V batteries.
- Battery status control.
- Installation on valves with the M30x1.5mm threaded connection.
- Capability to install on Danfoss RA, Danfoss RAV and Danfoss RAVL valves (adapters provided).
- Reducer ring provided for easier installation on valves with smaller diameter.

### **3.26 Smart Plug (ASW-200)**

---

It turns ON / OFF any 230 VAC electrical appliance connected to its outlet.

- Control of electrical appliances up to 2300 W.
- Relay switched on when the voltage is at the zero cross point.
- LED indicator.
- Firmware protection against overload and overheating.
- Powered by 230 VAC.

### **3.27 Smart 2-CH Relay (ASW-210)**

---

It turns ON / OFF up to two 230 VAC electrical appliances.

- 2 relay outputs:
  - remote control,
  - local control by means of control inputs,
  - galvanic isolation of the outputs.

- 2 control inputs:
  - capability to connect a double push-button or a switch,
  - local control of the relay output,
  - capability to control any device in the system.
- Powered by 230 VAC.
- Installed in a flush- or surface-mounted junction box with a minimum diameter of 60 mm.

### **3.28 Smart Keyfob (APT-210)**

---

It remotely controls the system.

- 5 buttons.
- 3 LED indicators.
- Built-in sounder.
- Powered by CR 2032 3 V battery.
- Battery status control.

### **3.29 Smart Switch Controller (ATX-200)**

---

It enables electrical switches to be used to control the BE WAVE system.

- 4 control inputs:
  - capability to operate a push-button or a switch,
  - capability to control any device in the system.
- Powered by CR14250 3 V battery.
- Battery status control.
- Installed in a flush- or surface-mounted junction box with a minimum diameter of 60 mm.

### **3.30 Smart Button (APB-210)**

---

It controls the system.

- Control by:
  - single push,
  - double push,
  - triple push,
  - long hold.
- Powered by CR2032 3 V battery.
- Battery status control.

### **3.31 Smart Repeater (ARU-200)**

---

The radio signal repeater extends the range of radio communication in the BE WAVE system. This allows you to install wireless devices further away from the controller.

- Retransmission of signals from 48 wireless devices.
- LED indicator.
- Powered by 230 VAC.
- Backup battery.
- Battery charging circuit.
- Battery status control and low battery disconnect system.

- Tamper protection against enclosure opening.



*The repeater does not support the Motion Detector Cam (APCAM-200) and the Outdoor Siren (ASP-200).*

*If a wireless device sends transmissions through the Smart Repeater, its firmware will not be updated remotely.*

## 4. Installation

---



**If the device is mounted higher than 2 m above the ground, it can become a danger when it falls off the wall.**

**There is a danger of battery explosion when using a different battery than recommended by the manufacturer, or handling the battery improperly.**

**Do not crush the battery, cut it or expose it to high temperatures (throw it into the fire, put it in the oven, etc.).**

**Do not expose the battery to very low pressure due to the risk of battery explosion or leakage of flammable liquid or gas.**

### 4.1 Installing the Smart HUB Plus / Smart HUB controller

---



**The controller can be connected to a power outlet whose voltage is the same as the voltage indicated on the controller's rating plate.**

**Do not connect the controller to a power outlet if the controller power cable or enclosure are damaged.**

**Do not touch the power cable plug with wet hands.**

**Do not pull the cable to disconnect it from the outlet. Pull the plug instead.**

**If smoke is coming out of the device, disconnect the power cable from the outlet.**

**Do not place heavy objects on the controller.**

**Do not install the controller at locations above 2000 m above sea level.**

### 4.1.1 Description of the Smart HUB Plus / Smart HUB controller

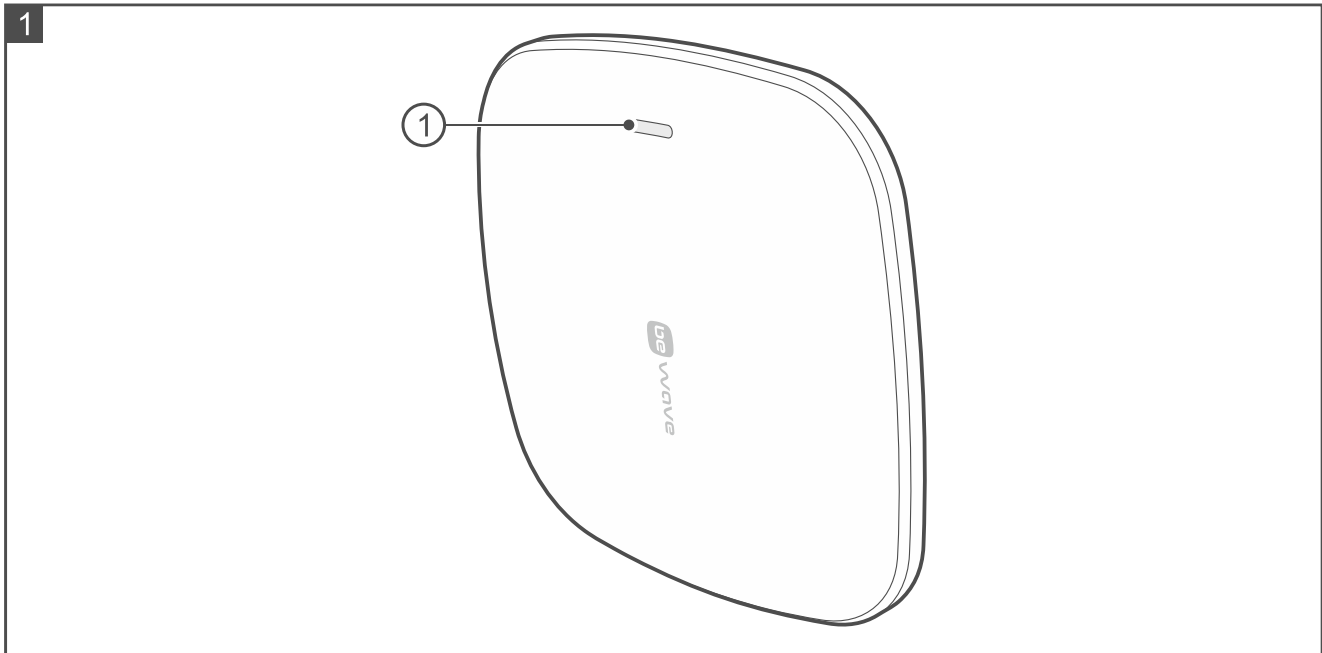

Figure 1 shows the controller's front side:

- ① LED indicator:
- flashing in pink – controller startup in progress,
  - ON in pink – controller operates in the Wi-Fi access point mode (you can connect to the controller in the BEWAVE\_AP network),
  - ON in blue – controller is connected to a local network but has no access to the Internet or no connection to the SATEL server,
  - ON in green – controller is connected to the Internet,
  - additionally flashing in yellow – trouble,
  - additionally flashing in red – alarm,
  - colors changing smoothly – controller's firmware update in progress,
  - ON in white – controller's factory reset in progress.

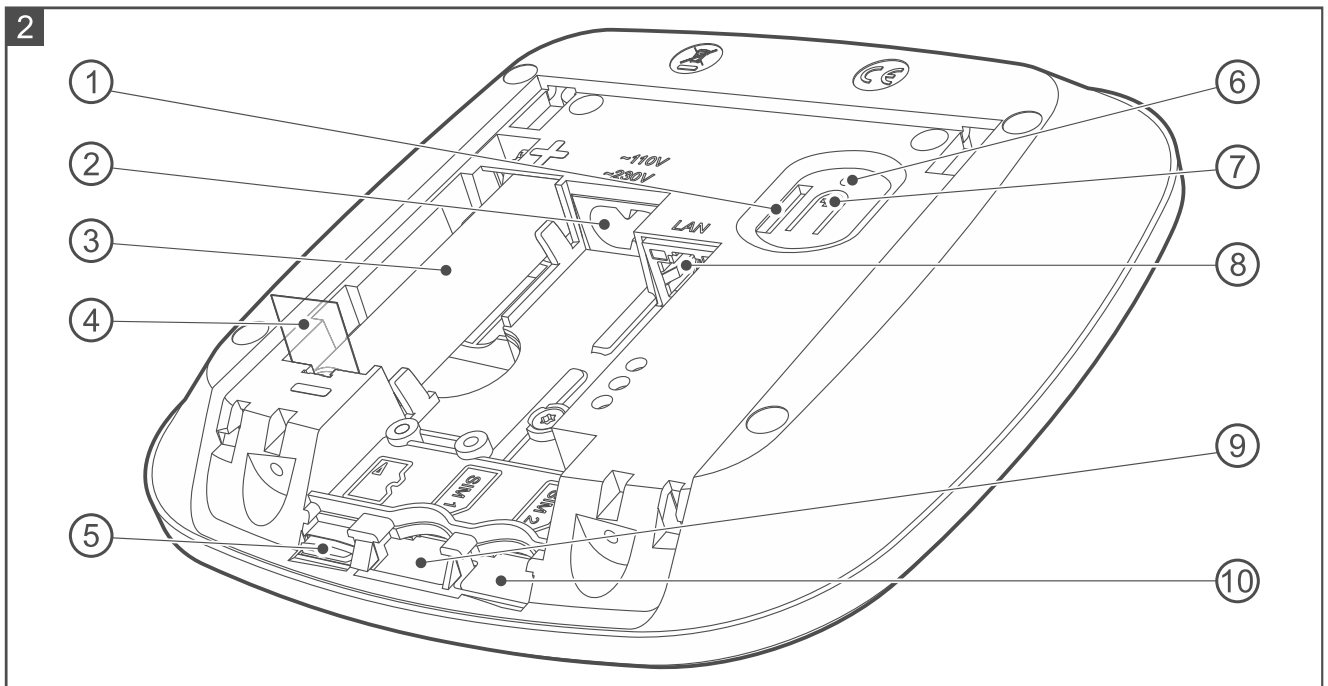

Figure 2 shows the inside of the Smart HUB Plus / Smart HUB controller after opening the enclosure.

- ① tamper protection.
- ② power cable port.
- ③ lithium-ion rechargeable battery (3.6 V / 3200 mAh).
- ④ battery insulator pull tag.
- ⑤ SD memory card (factory-installed). Stored on the SD card are:
  - backup settings (in order to restore settings in case of trouble or copy settings to another controller),
  - photos sent by the Motion Detector Cam,
  - photos used in the Be Wave app (for personalized room views),
  - data from devices measuring temperature, pressure, humidity, power consumption, etc.,
  - file of system items names (it can be created if the file is to be forwarded to the monitoring station).
- ⑥ factory reset pinhole – see “Hardware factory restore” p. 117.
- ⑦ button to enable / disable the Wi-Fi access point mode (press and hold for 5 seconds).
- ⑧ LAN cable port.
- ⑨ SIM1 slot for first SIM card [Smart HUB Plus].
- ⑩ SIM2 slot for second SIM card [Smart HUB Plus].

#### 4.1.2 Installation tips for the Smart HUB Plus / Smart HUB controller

- The controller should be installed indoors, in spaces with normal air humidity.
- You can mount the controller on the wall or place it on a tabletop.
- The place of installation should be close to a 230 VAC power outlet. The outlet must be readily available.
- The electrical circuit to which the controller is to be connected must have suitable protection.

- The BE WAVE wireless devices you are planning to install must be within the range of the controller’s radio communication. Keep this in mind when selecting a place of installation for the controller. Please note that thick walls, metal partitions, etc. will reduce the range of the radio signal.

### 4.1.3 Mounting the Smart HUB Plus / Smart HUB controller

**i** *If the controller is to meet the requirements of Standard EN 50131 for Grade 2, mount the controller on the wall.*

*Do not mount the controller on the wall with cables pointing upwards.*

*If the controller is to remain placed on the tabletop, skip steps 2, 3 and 5 and apply adhesive anti-slip pads on the bottom of the enclosure (Fig. 14). The pads are supplied with the controller.*

1. Open the controller enclosure (Fig. 3).

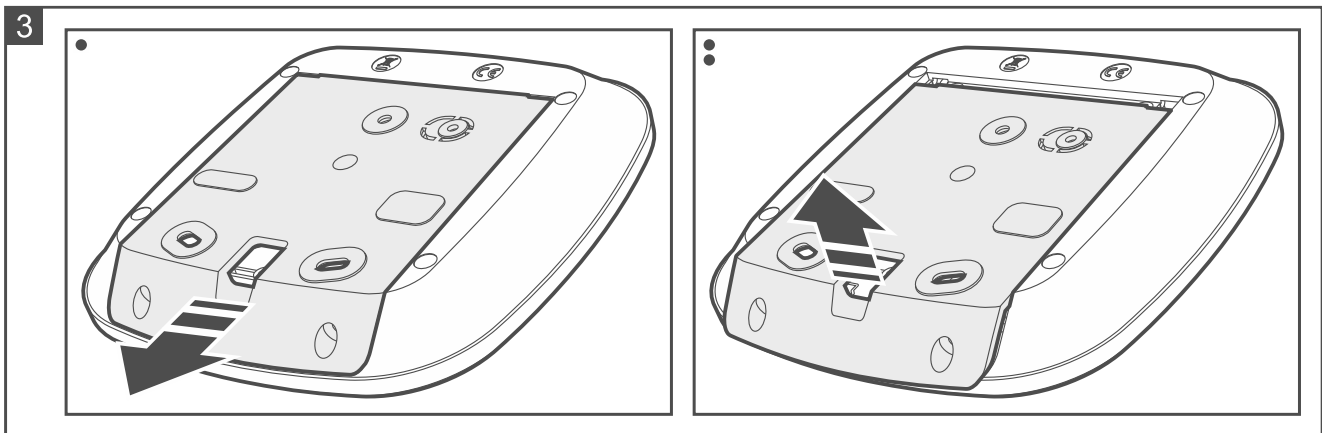

2. Place the enclosure base against the wall and mark the location of the mounting holes (Fig. 4). If the controller is to detect removal from the surface, mark the location of the hole in the tamper protection element (marked with the **T** symbol in the figure).

**i** *The controller must detect removal from the surface if it is to meet the requirements of Standard EN 50131 for Grade 2.*

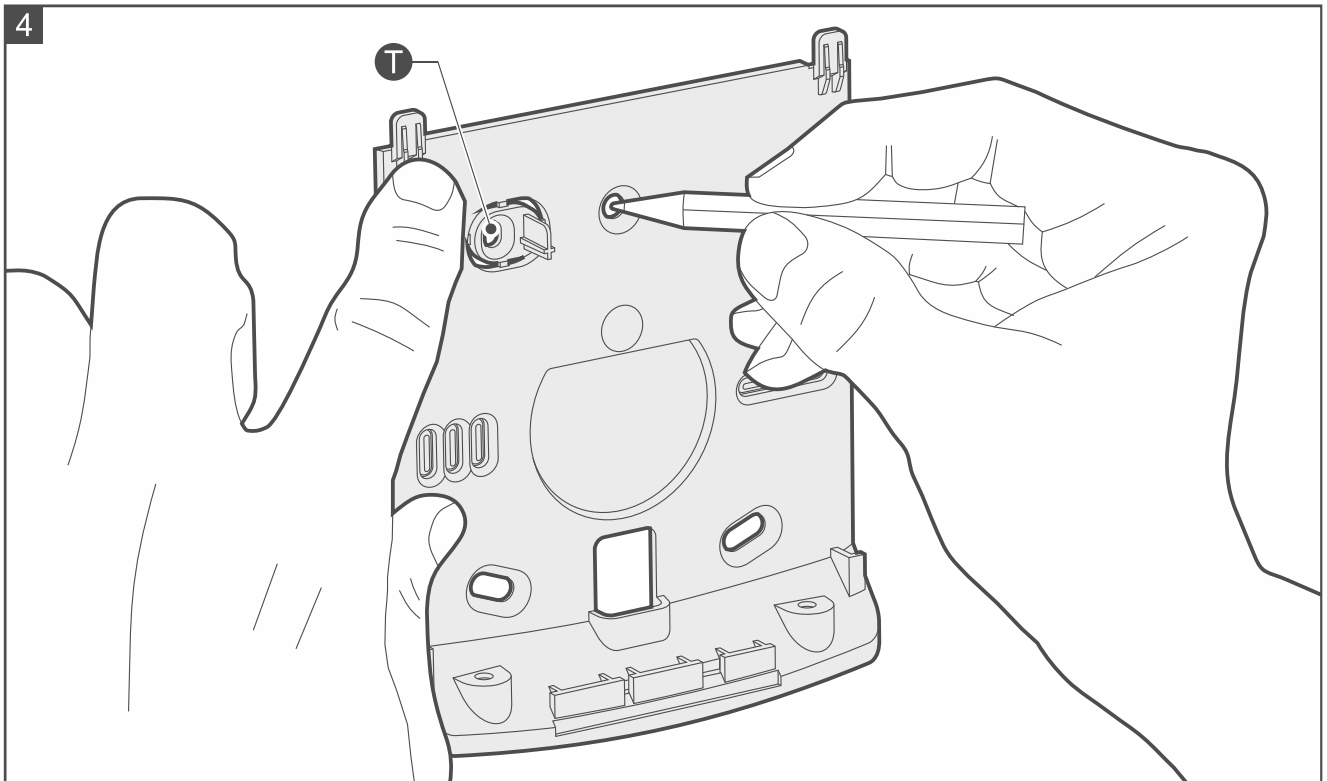

3. Drill the holes in the wall for wall plugs (anchors). Use wall plugs specifically intended for the mounting surface (different for concrete or brick wall, different for plaster wall, etc.).
4. Run the cable(s) through the opening in the enclosure base (Fig. 5).
5. the enclosure base to the wall with screws (Fig. 6).

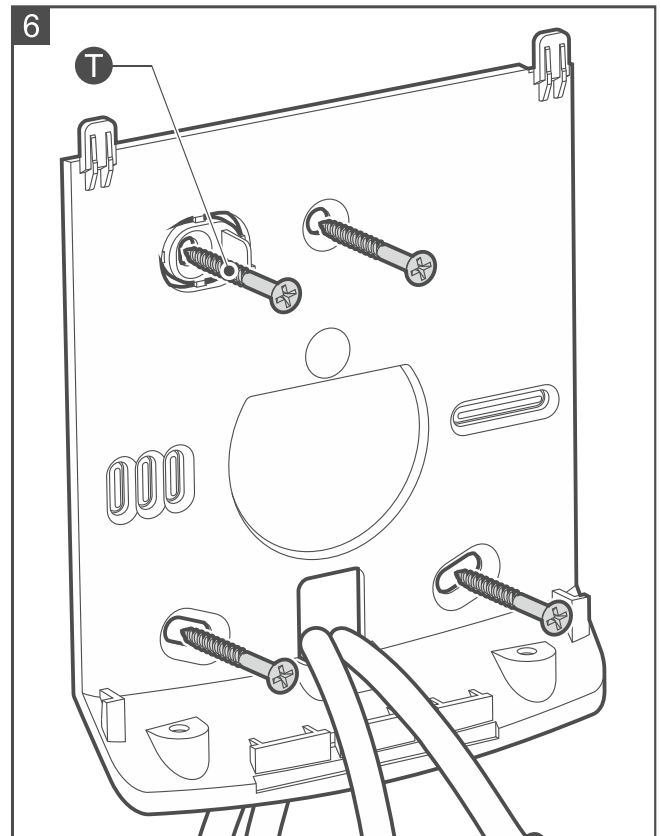
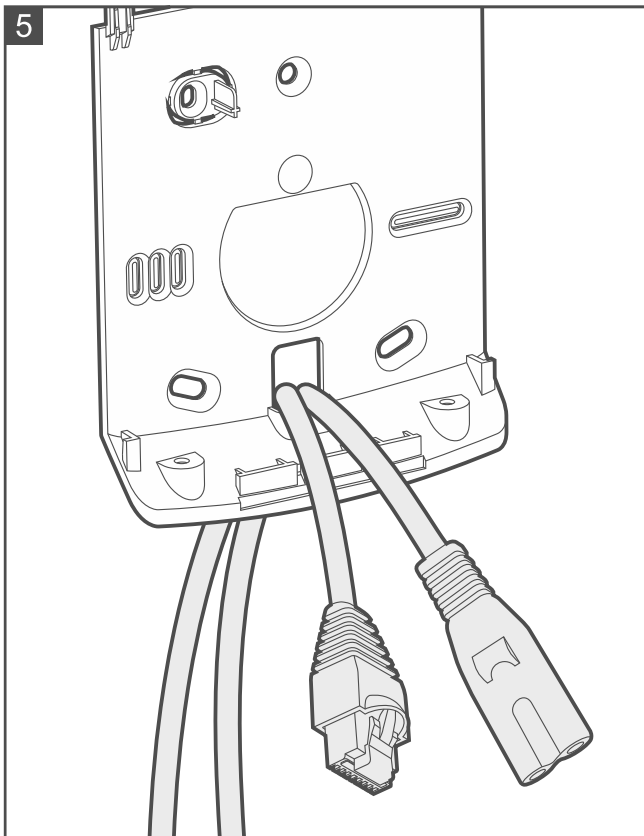

6. Insert a mini SIM card into the SIM1 slot (Fig. 7) [Smart HUB Plus].

7. If you want to use two cards, insert the second mini SIM card into the SIM2 slot (Fig. 8) [Smart HUB Plus].

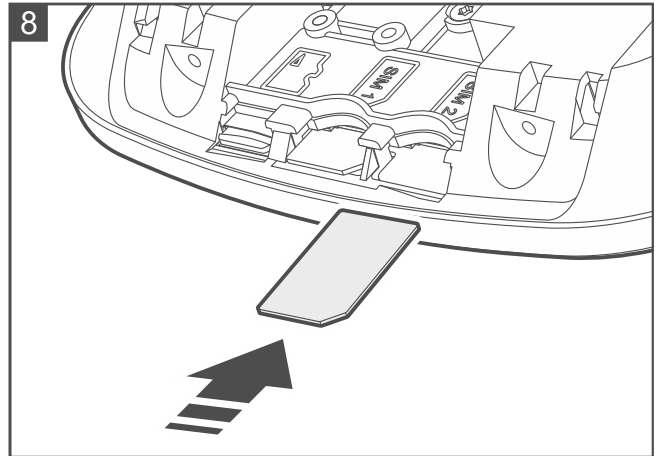
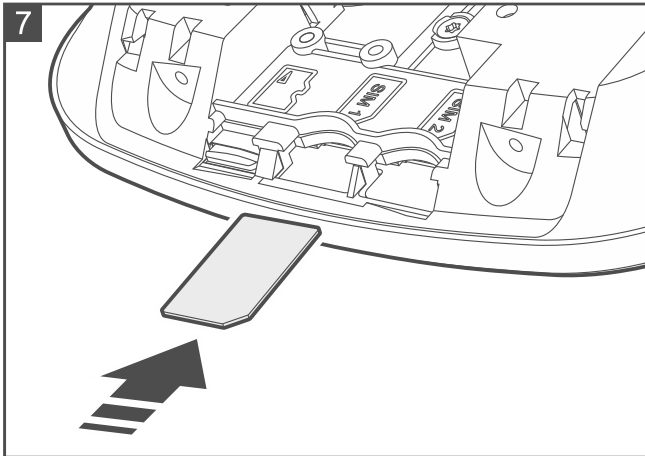

8. If the controller is to be connected to the wired LAN network, connect the cable to the LAN port (Fig. 9). Use a cable compliant with the 100Base-TX standard with the RJ-45 plug (the same as for connecting the computer to the network).

**!** The controller can only operate in the local area networks (LAN). It must not be connected directly to the public computer network (MAN, WAN). To establish connection with a public network, use a router or xDSL modem.

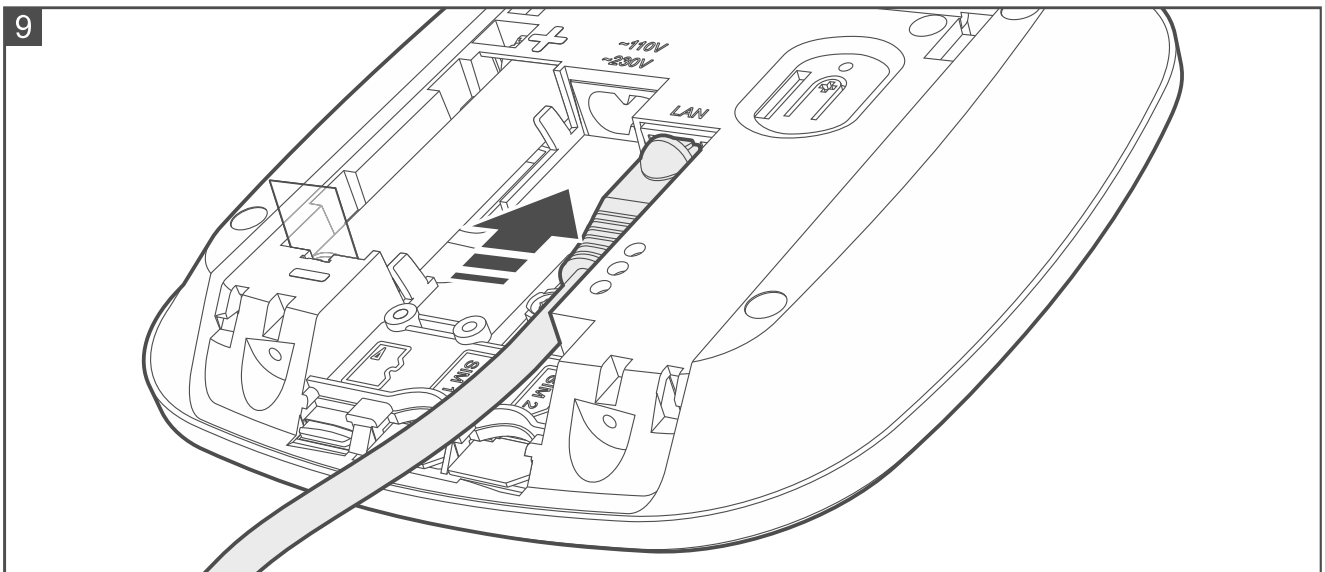

9. Connect the power cable to the power cable port in the controller (Fig. 10) and secure the cable fastener with screws (Fig. 11).

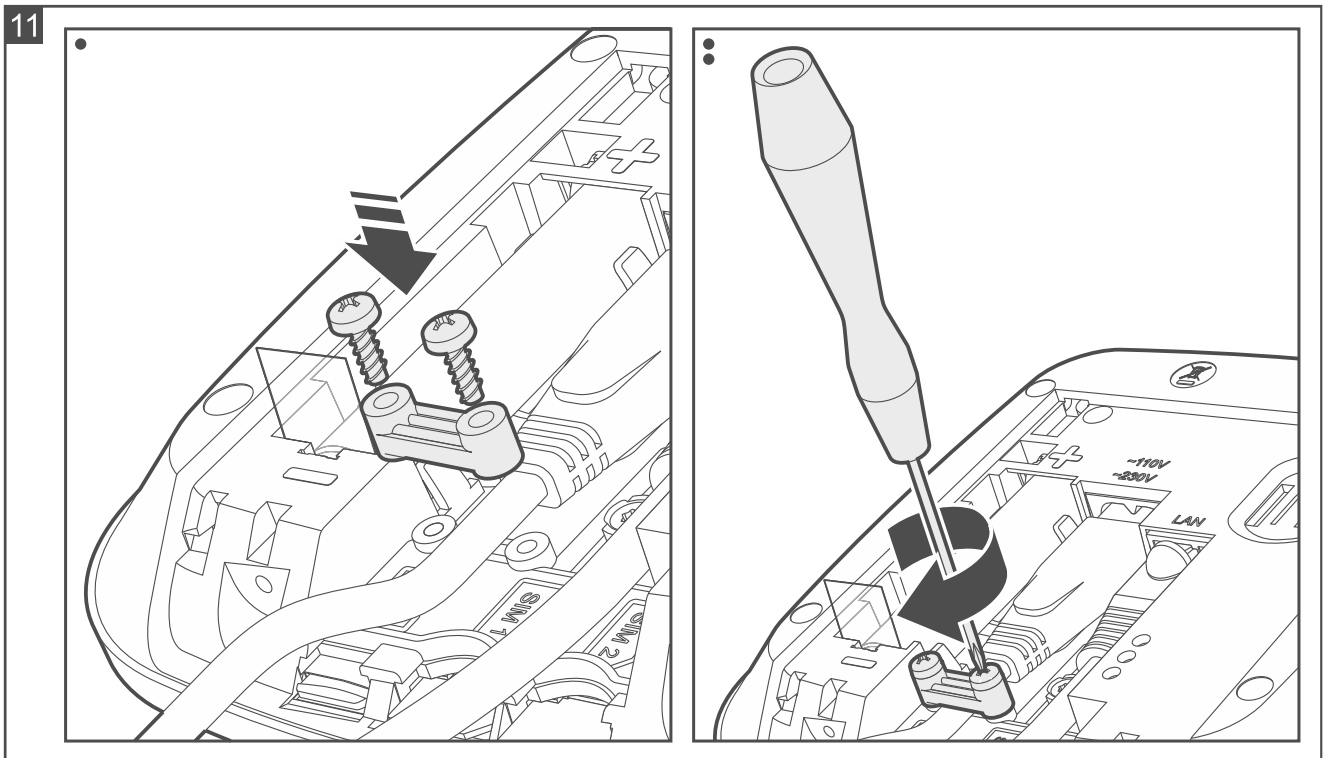
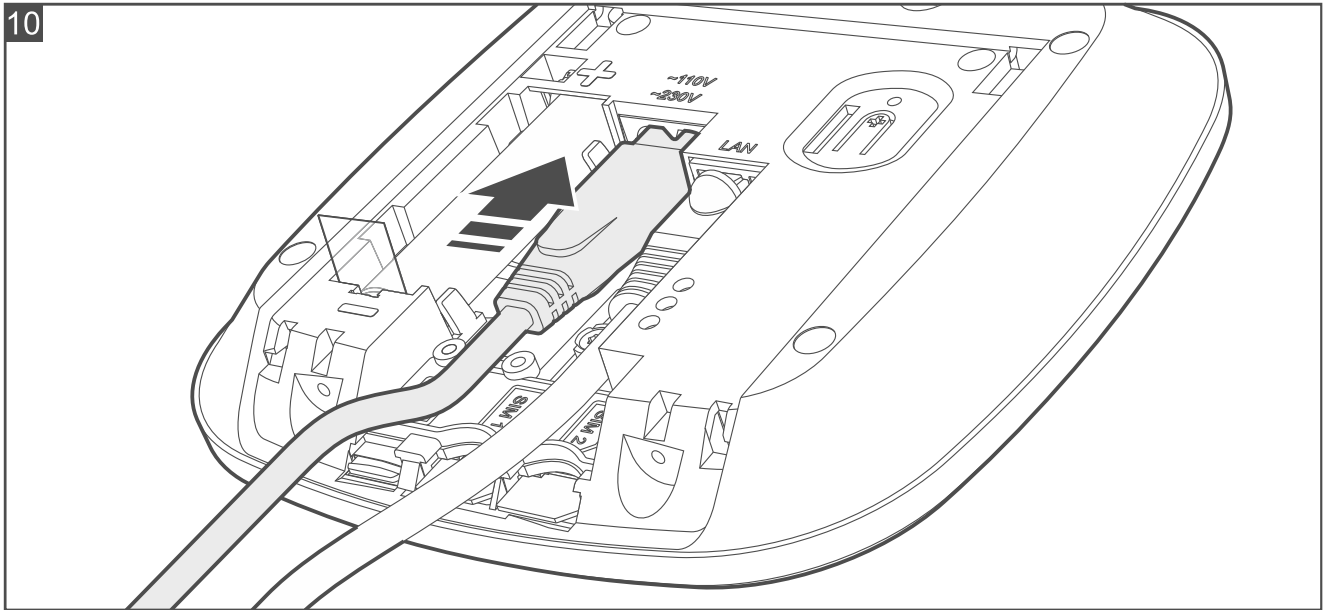

10. Remove the battery insulator tag (Fig. 12). The controller will power on (the controller LED indicator will start flashing).

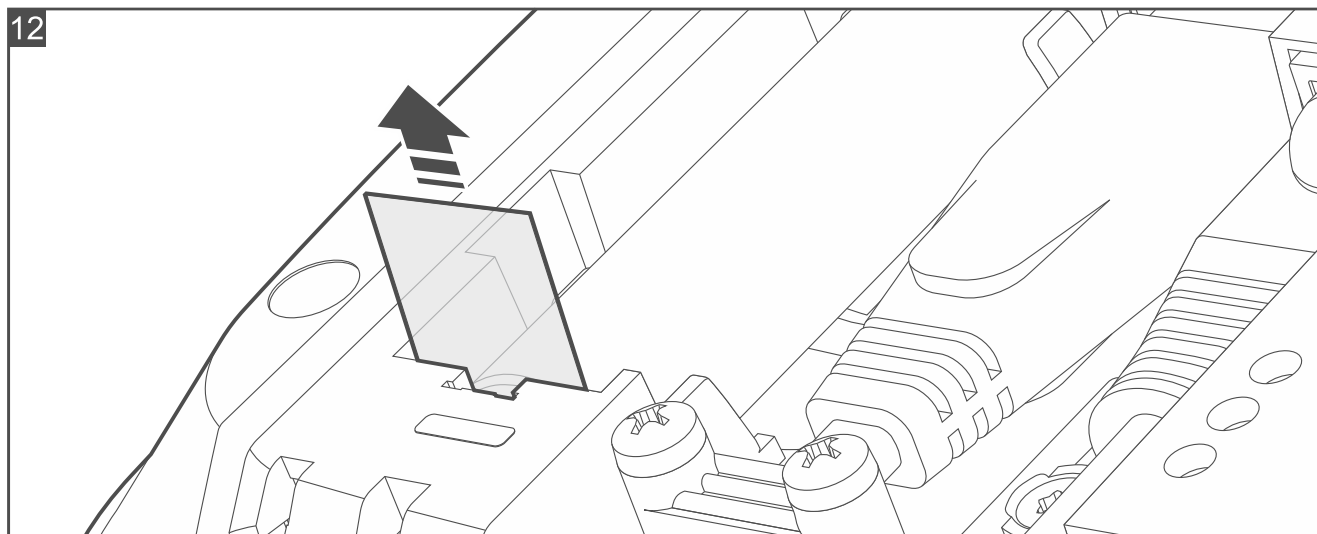

11. Close the enclosure and secure it with screws (Fig. 13).

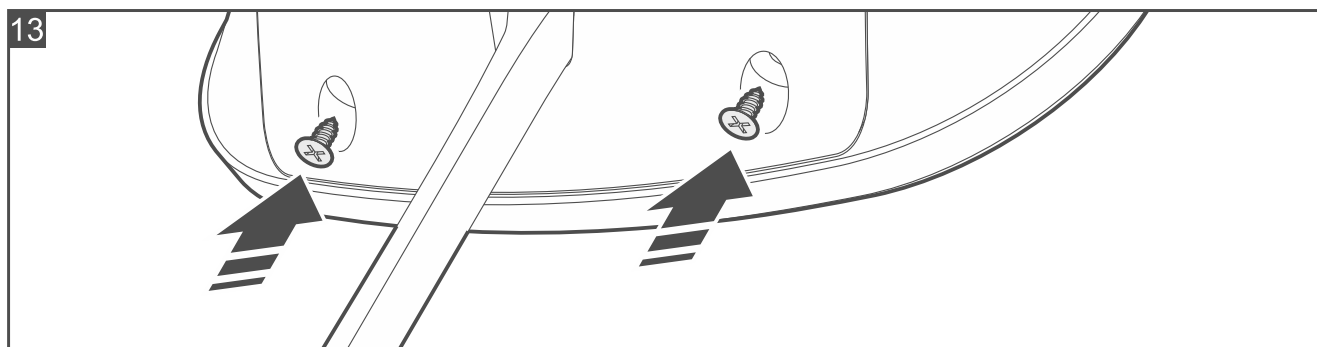

12. Plug the power cable to the power outlet.

13. Start the Be Wave app to configure the controller settings and add BE WAVE devices.

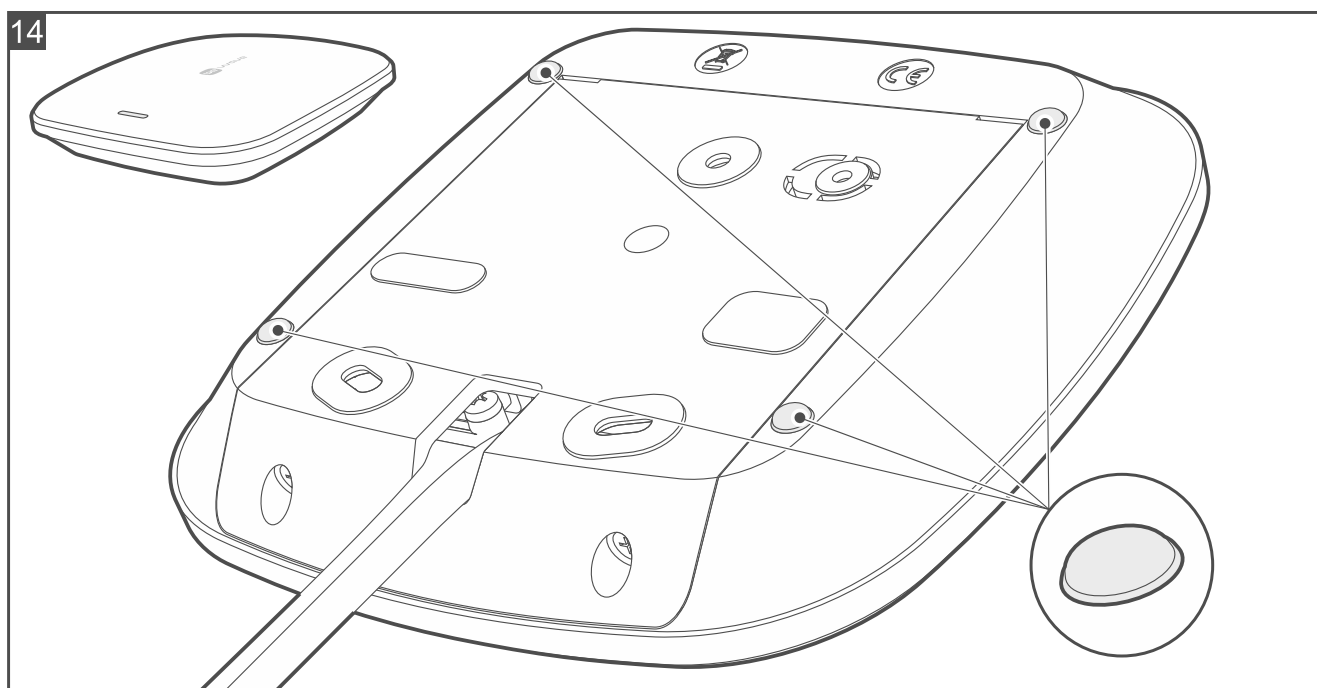

## 4.2 Installing the Smart HUB Plus LV controller



Disconnect power before making any electrical connections.

Do not place heavy objects on the controller.

### 4.2.1 Description of the Smart HUB Plus LV controller

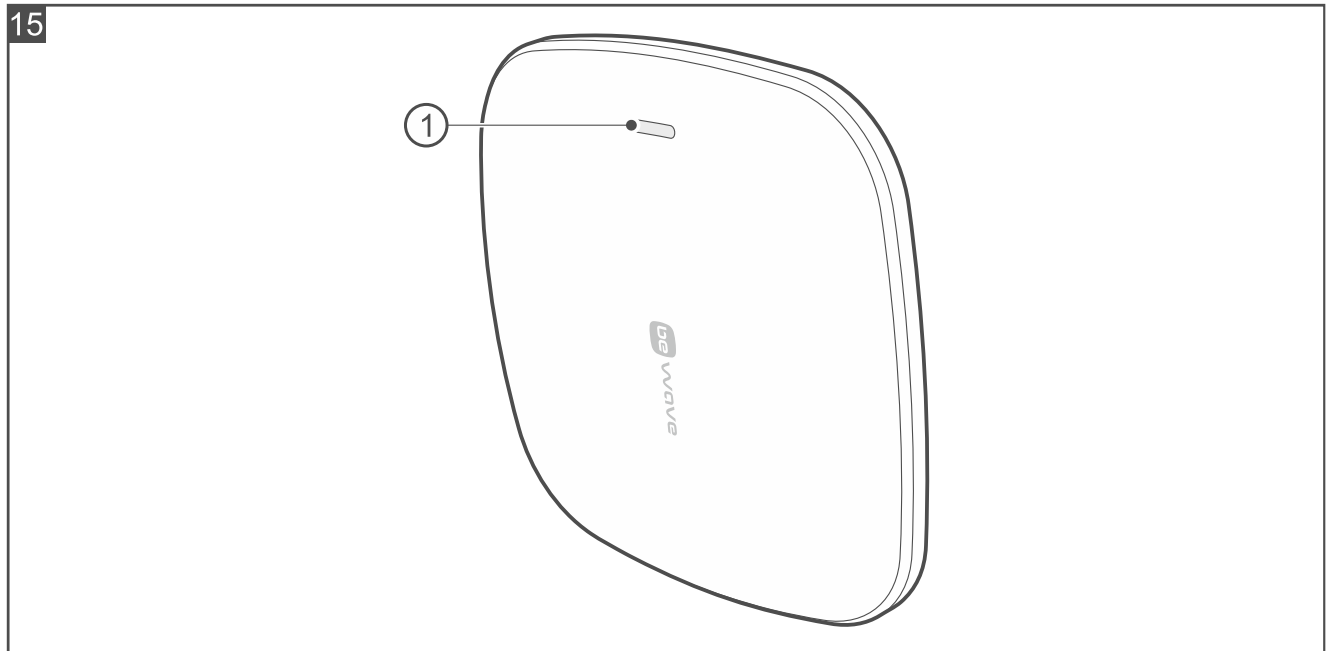

Figure 15 shows the controller's front side:

#### ① LED indicator:

flashing in pink – controller startup in progress,

ON in pink – controller operates in the Wi-Fi access point mode (you can connect to the controller in the BEWAVE\_AP network),

ON in blue – controller is connected to a local network but has no access to the Internet or no connection to the SATEL server,

ON in green – controller is connected to the Internet,

additionally flashing in yellow – trouble,

additionally flashing in red – alarm,

colors changing smoothly – controller's firmware update in progress,

ON in white – controller's factory reset in progress.

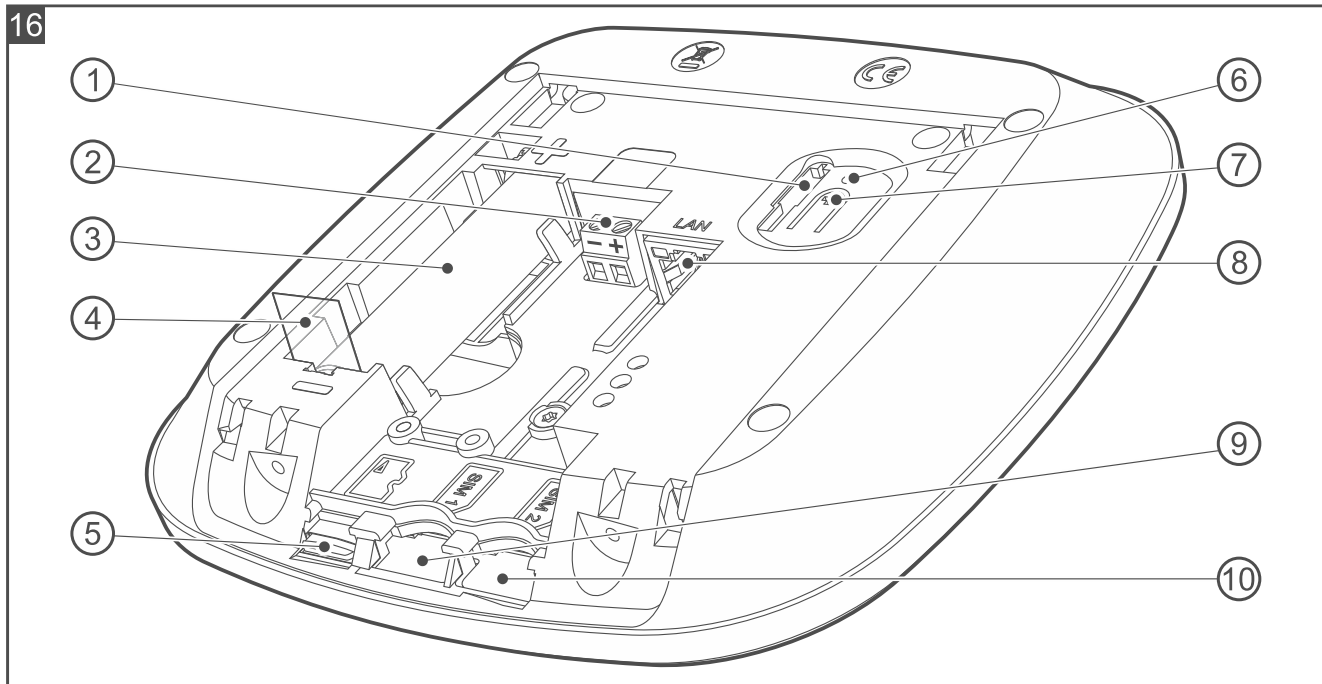

Figure 16 shows the inside of the Smart HUB Plus LV controller after opening the enclosure.

- ① tamper protection.
- ② 9...28 VDC terminals.
- ③ lithium-ion rechargeable battery (3.6 V / 3200 mAh).
- ④ battery insulator pull tag.
- ⑤ SD memory card (factory-installed). Stored on the SD card are:
  - backup settings (in order to restore settings in case of trouble or copy settings to another controller),
  - photos sent by the Motion Detector Cam,
  - photos used in the Be Wave app (for personalized room views),
  - data from devices measuring temperature, pressure, humidity, power consumption, etc.,
  - file of system items names (it can be created if the file is to be forwarded to the monitoring station).
- ⑥ factory reset pinhole – see “Hardware factory restore” p. 117.
- ⑦ button to enable / disable the Wi-Fi access point mode (press and hold for 5 seconds).
- ⑧ LAN cable port.
- ⑨ SIM1 slot for first SIM card.
- ⑩ SIM2 slot for second SIM card.

#### 4.2.2 Installation tips for the Smart HUB Plus LV controller

- The controller should be installed indoors, in spaces with normal air humidity.
- You can mount the controller on the wall or place it on a tabletop.
- The BE WAVE wireless devices you are planning to install must be within the range of the controller’s radio communication. Keep this in mind when selecting a place of installation for the controller. Please note that thick walls, metal partitions, etc. will reduce the range of the radio signal.

### 4.2.3 Mounting the Smart HUB Plus LV controller



*If the controller is to meet the requirements of Standard EN 50131 for Grade 2, mount the controller on the wall.*

*Do not mount the controller on the wall with cables pointing upwards.*

*If the controller is to remain placed on the tabletop, skip steps 2, 3 and 5 and apply adhesive anti-slip pads on the bottom of the enclosure (Fig. 14). The pads are supplied with the controller.*

1. Open the controller enclosure (Fig. 17).

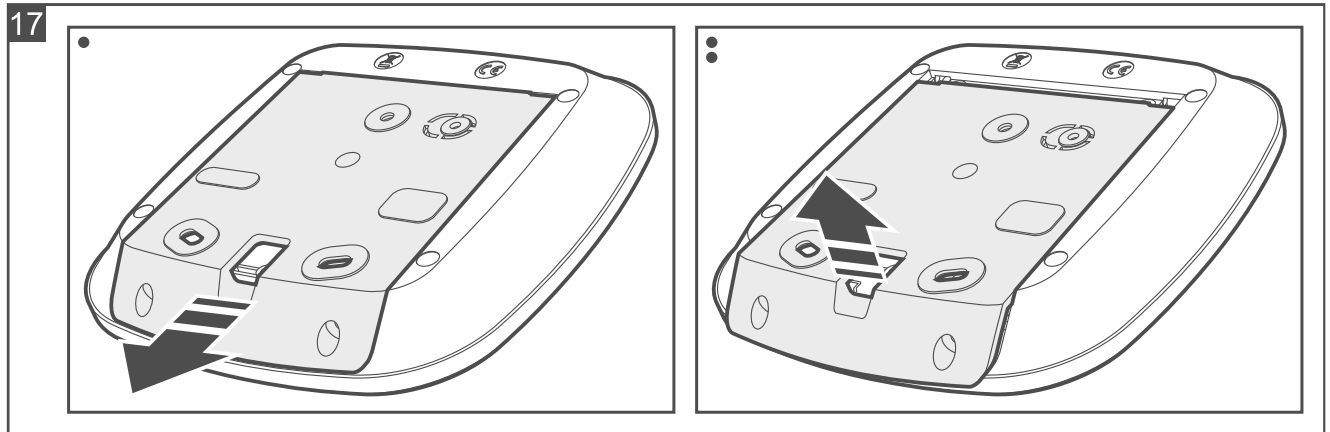

2. Place the enclosure base against the wall and mark the location of mounting holes (Fig. 18). If the controller is to detect removal from the surface, mark the location of the hole in the tamper protection element (marked with the **T** symbol in the figure).



*The controller must detect removal from the surface if it is to meet the requirements of Standard EN 50131 for Grade 2.*

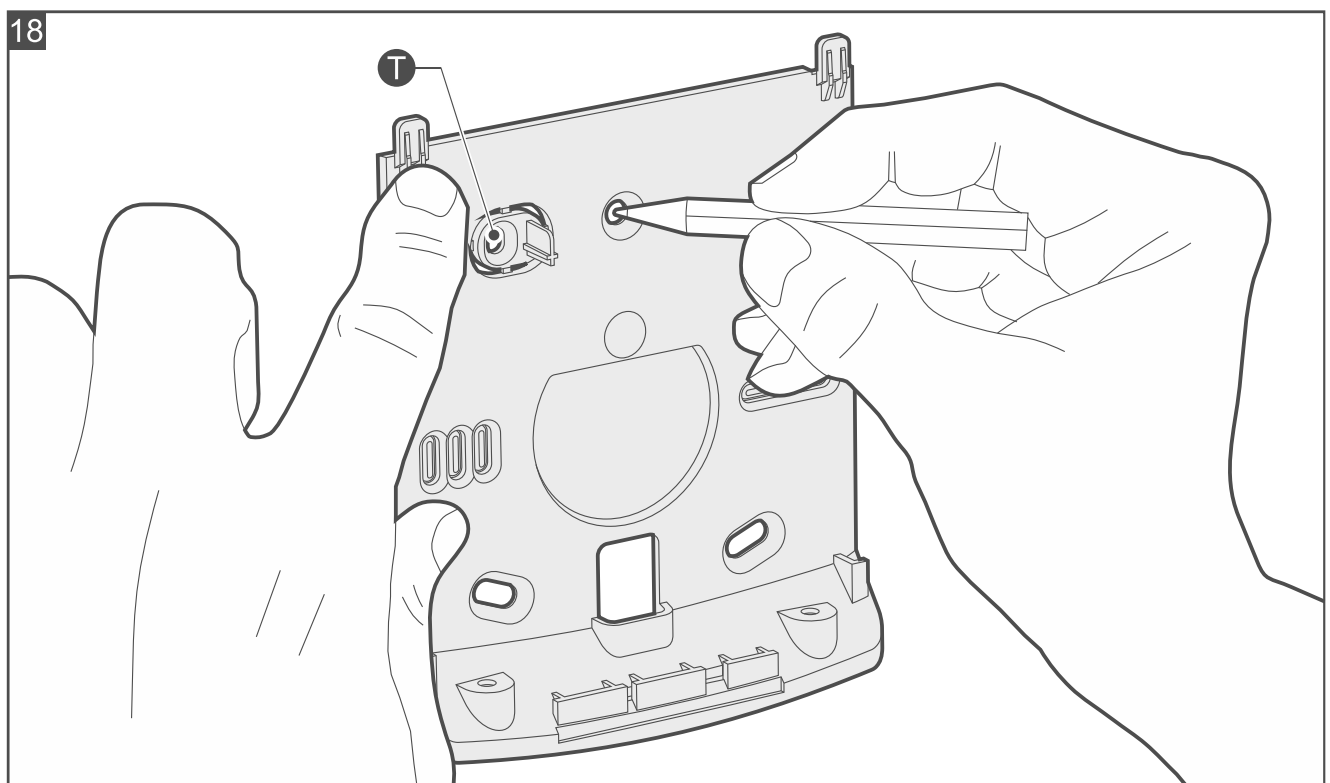

- 3. Drill the holes in the wall for wall plugs (anchors). Use wall plugs specifically intended for the mounting surface (different for concrete or brick wall, different for plaster wall, etc.).
- 4. Run the cable(s) through the opening in the enclosure base (Fig. 19).
- 5. Secure the enclosure base to the wall with screws (Fig. 20).

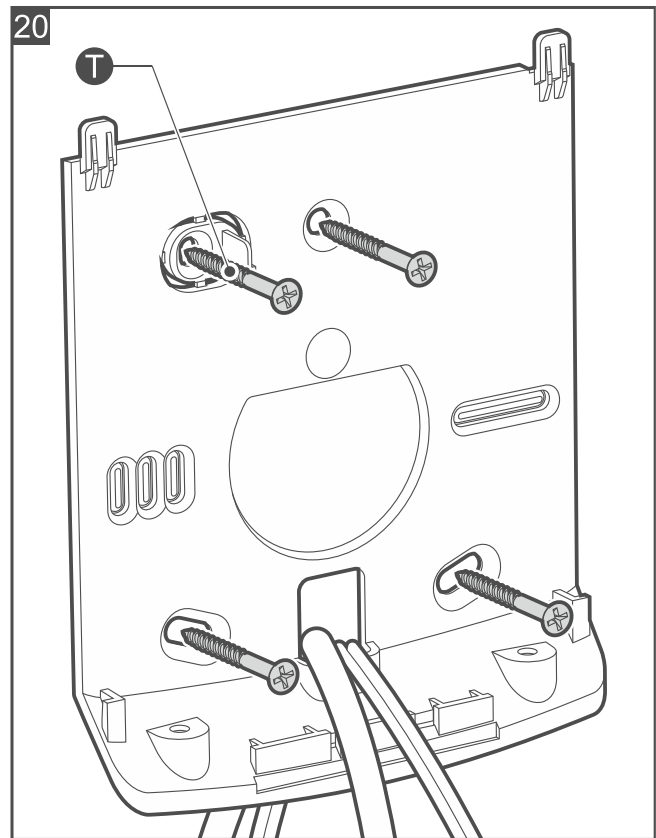
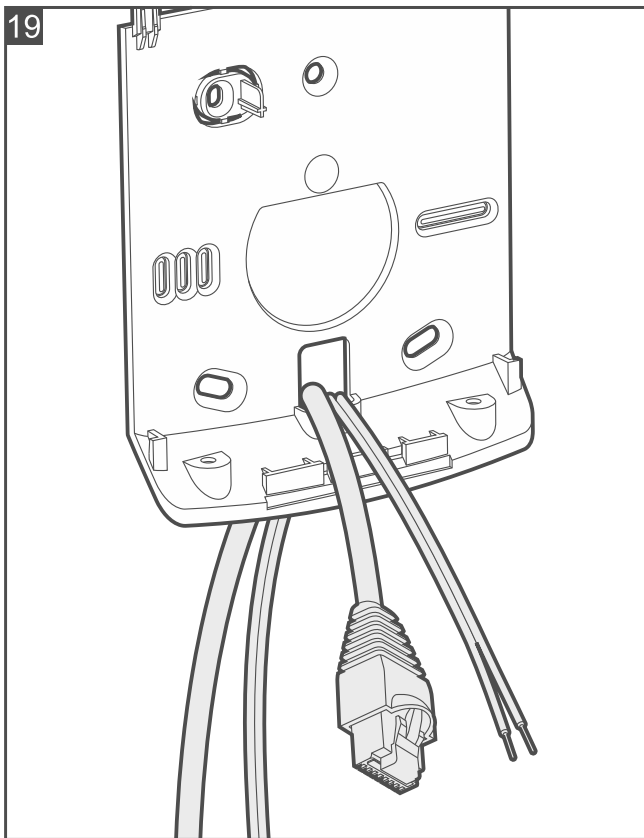

- 6. Insert a mini SIM card into the SIM1 slot (Fig. 21).
- 7. If you want to use two cards, insert the second mini SIM card into the SIM2 slot (Fig. 22).

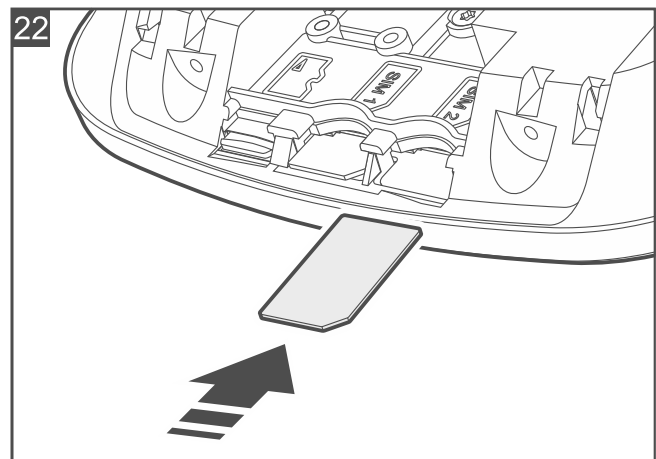
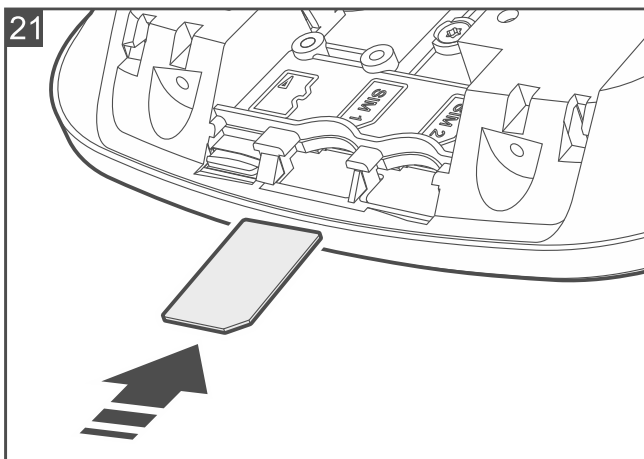

- 8. If the controller is to be connected to the wired LAN network, connect the cable to the LAN port (Fig. 23). Use a cable compliant with the 100Base-TX standard with the RJ-45 plug (the same as for connecting the computer to the network).

**!** The controller can only operate in the local area networks (LAN). It must not be connected directly to the public computer network (MAN, WAN). To establish connection with a public network, use a router or xDSL modem.

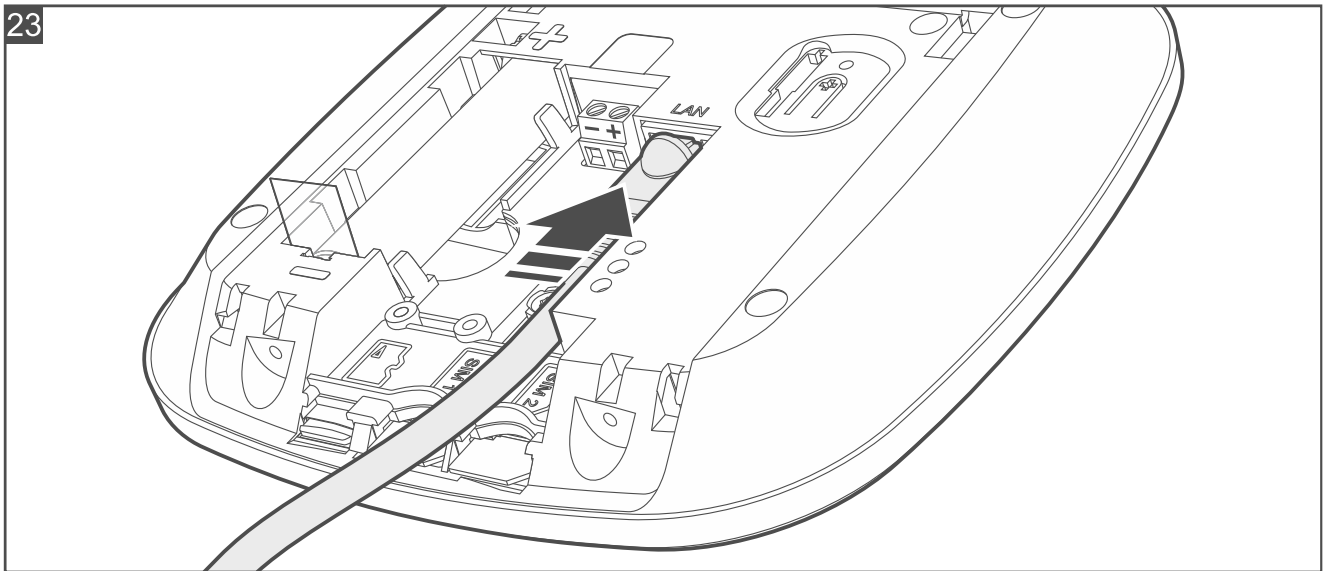

9. Screw the power wires to the terminals (Fig. 24) and secure the power wires fastener with screws (Fig. 25).

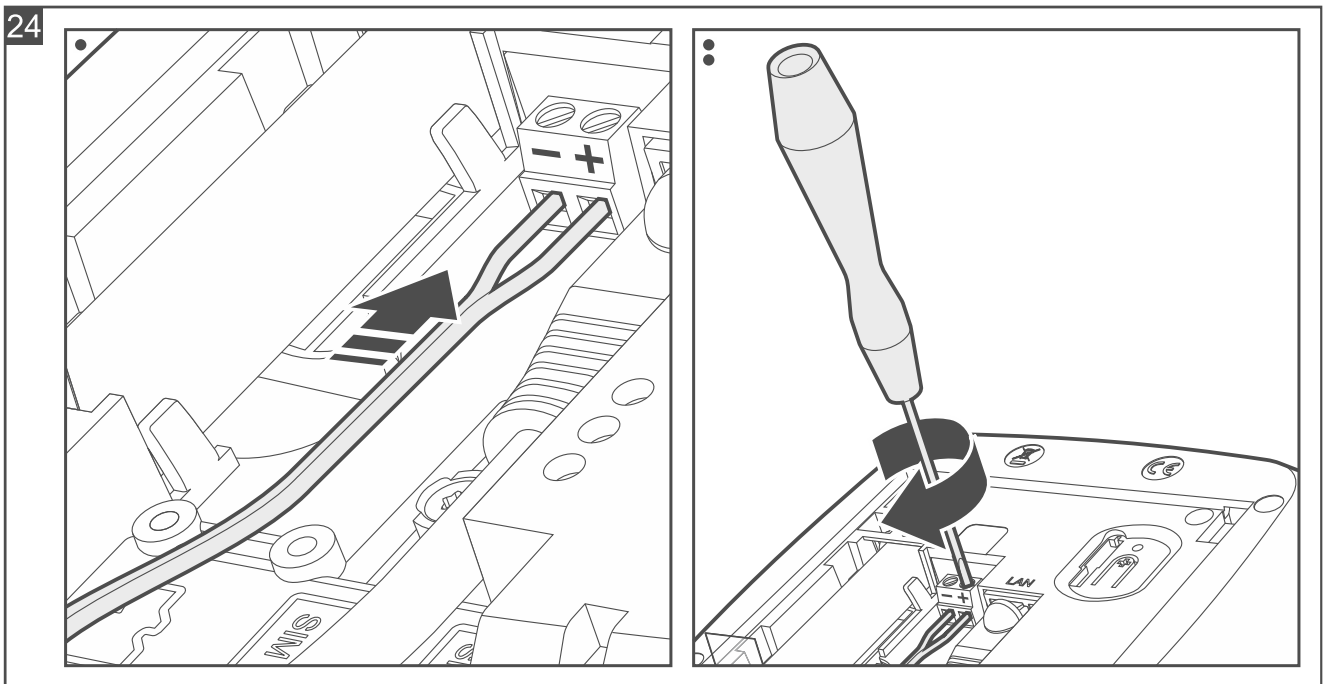

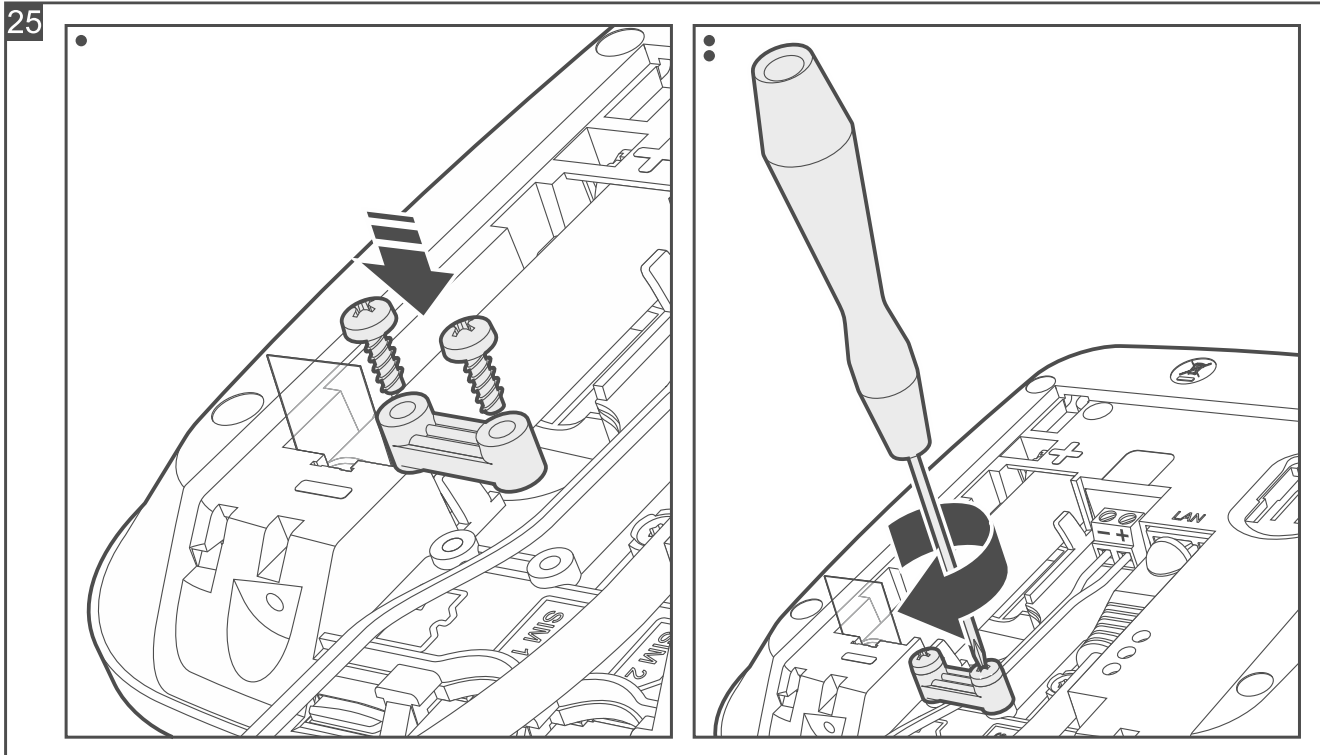

10. Remove the battery insulator tag (Fig. 26). The controller will turn on (the controller LED indicator will start flashing).

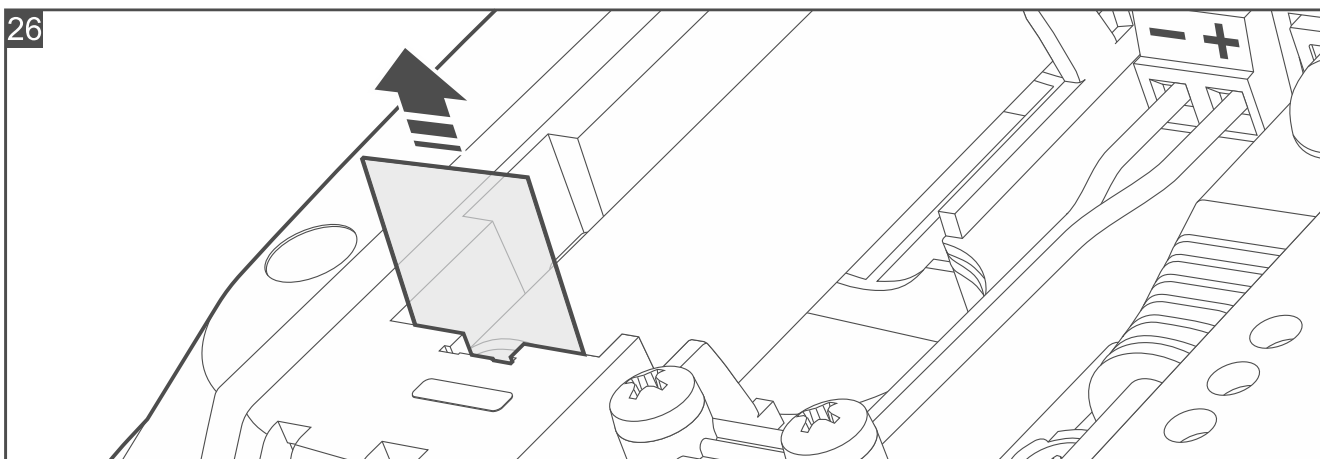

11. Close the enclosure and secure it with screws (Fig. 27).

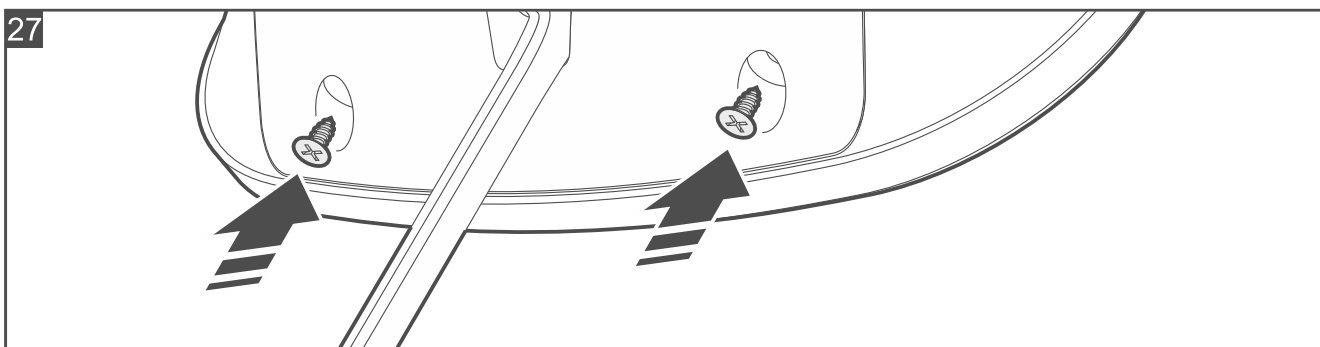

12. Power on the controller.

13. Start the Be Wave app to configure the controller settings and add BE WAVE devices.

## 4.3 Adding the controller to the Be Wave app



You can download the Be Wave app from “Google Play” (Android system devices) or “App Store” (iOS system devices). Required Android version: 11 (or newer). Required iOS version: 11 (or newer).

After start-up, the controller with factory settings operates in the Wi-Fi access point mode (the controller’s LED indicator is ON in pink). It allows the app to connect to the controller.

Before you start the BE WAVE app, connect your phone to the BEWAVE\_AP network. The network’s full name contains the MAC address of the controller. Make sure it is the MAC address of your controller.

1. Start the Be Wave app. The *Add new site* screen will be displayed.

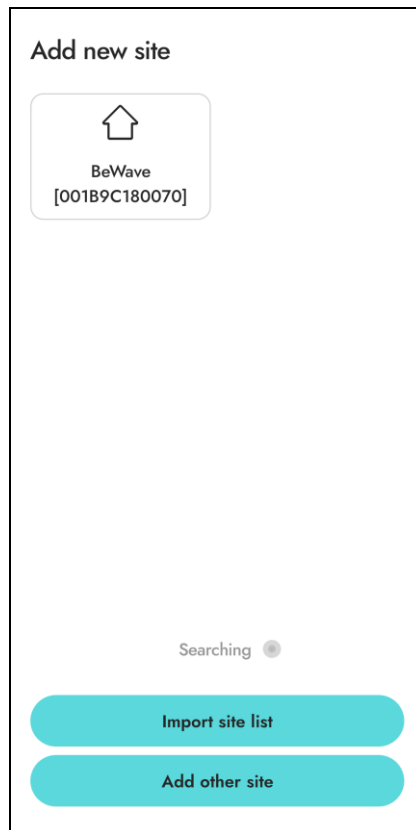

2. Tap the controller (site) you want to add. Different buttons will appear at the bottom of the screen.

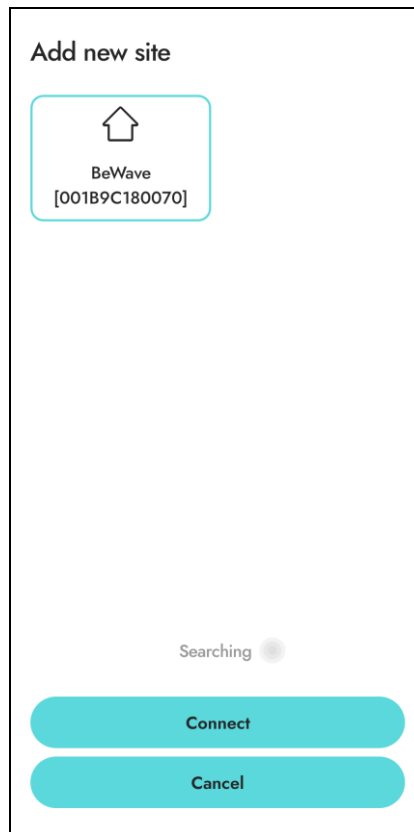

3. Tap *Connect*. The *New site – Site settings* screen will be displayed.

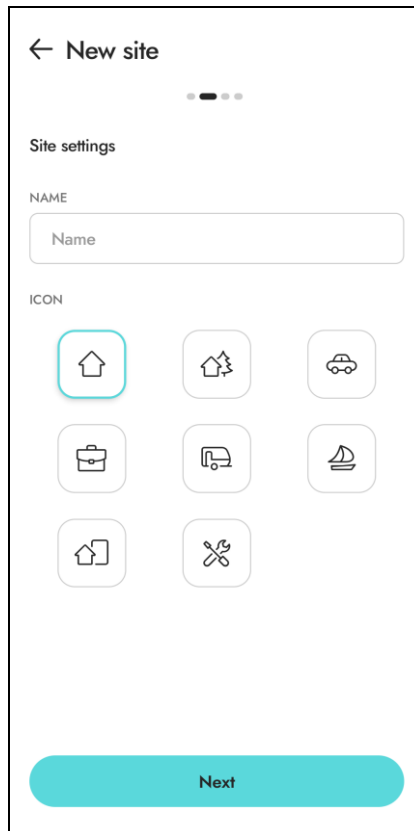

4. Enter the name of the site and select one of the icons to represent the site, then tap *Next*. The *New site – Admin account* screen will be displayed.

← New site

Admin account

USER

Enter username

PASSWORD

Enter password

Enter between 8 and 16 characters. Use at least one uppercase letter and a digit.

RETYPE PASSWORD

Retype password

Save

5. Enter the username and password for the administrator, then tap *Save*. The *New site – Communication methods* screen will be displayed.

← New site

Communication methods

SIM CARDS

SIM1

SIM2

LAN

LAN

WI-FI

\_gomis\_

DIRECT-7A-HP PageWide Pro 477dw

GUEST\_S

Huawei Play 24

Save

6. Select the communication method to be used with the controller. A new screen will be displayed. Configure the settings for the selected communication method, then save the

settings. You will return to the *New site – Communication methods* screen. Tap *Save*. A screen will be displayed saying that the controller is being prepared to work.



*While the controller is being prepared to work, the Wi-Fi access point mode will be disabled. The controller will switch to the selected communication method.*

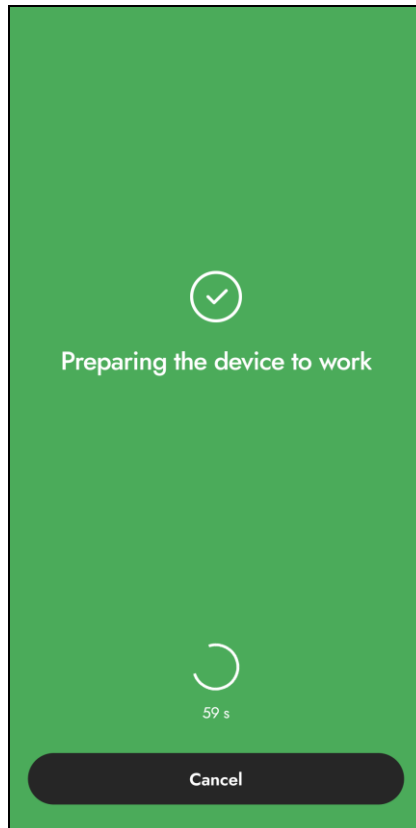

7. When the app connects to the controller by means of the selected communication method, the app's home screen will be displayed. You can add the first BE WAVE device.

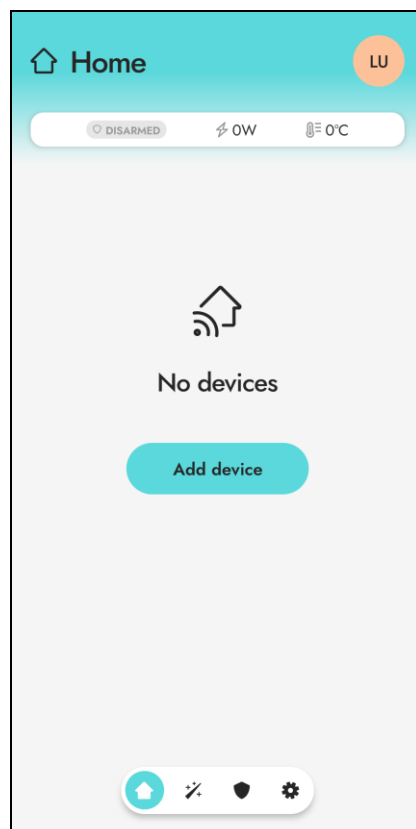

## 4.4 Adding a BE WAVE device to the system



*Before adding a device that was previously registered to the BE WAVE / ABAX 2 / ABAX system, you must restart it (remove the battery / power the device off for 30 seconds).*

### 4.4.1 Adding the first BE WAVE device

1. Tap the *Add device* button on the home screen. On a new screen you will be asked to turn on the device.

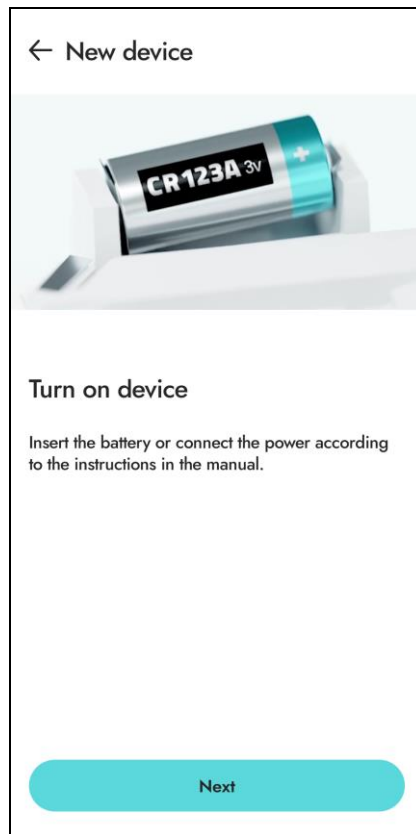

2. Insert the battery, connect the power, etc. (for detailed information, please refer to the sections on the installation of particular devices), then tap *Next*. The list of BE WAVE devices detected by the controller will be displayed (the screenshot is an example).

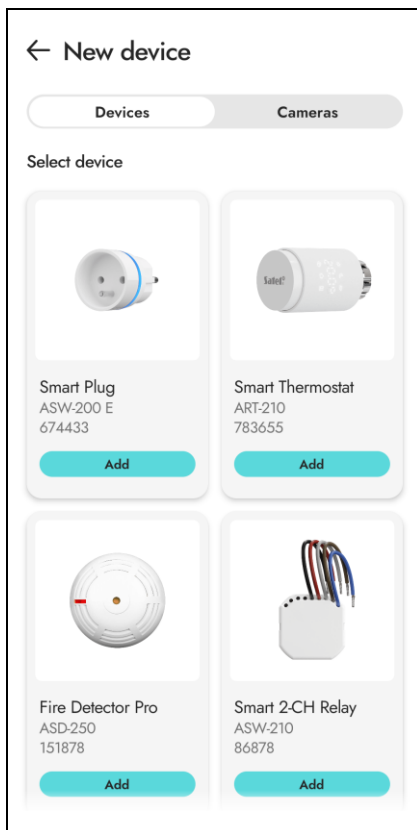

3. Tap the device you want to add. A screen with device settings will be displayed (the screenshot is an example).

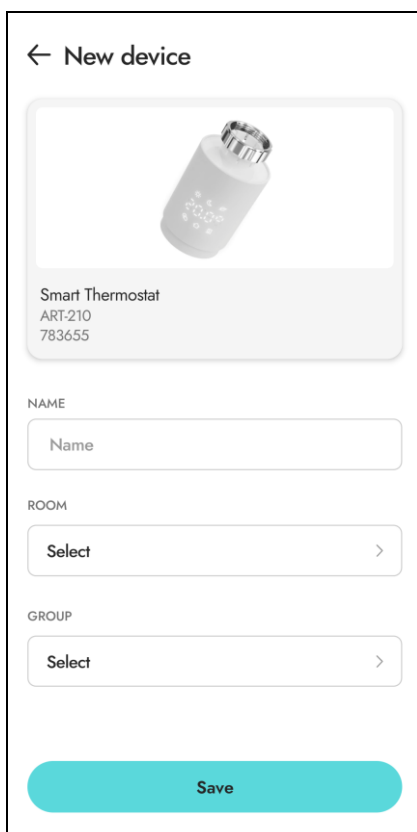

4. Configure the device settings (enter the name, assign the device to a room and to a group, etc.), then tap *Save*. A screen will be displayed saying that the device has been added.

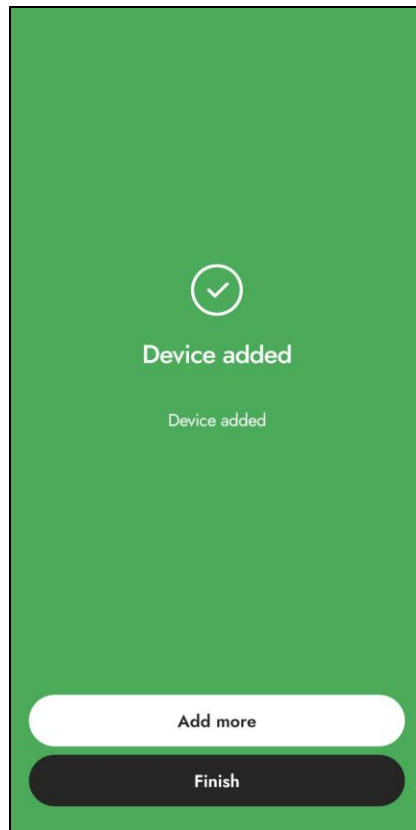

5. Tap *Add more* if you want to add another device or *Finish* if you do not want add any more devices.

#### 4.4.2 Adding another BE WAVE device

If you want to add another BE WAVE device, tap on the home screen and tap:

- group – at the bottom of the screen that will be displayed, the *Add device* button will be available.
- room – at the bottom of the screen that will be displayed, the *Add device* button will be available.
-  icon – at the bottom of the screen that will be displayed, the *Add device* button will be available.

When you tap the *Add device* button, the process of adding the device is the same as for the first device.

## 4.5 Installing BE WAVE devices

---



*When selecting a place of installation, consider the radio communication range.*

*Thick walls, metal partitions, etc. reduce the range of the radio signal.*

*If you are using a double-sided mounting tape, remember to press it properly. First, stick the tape to the device and keep pressing for several seconds, then stick the device to the surface and keep pressing for several seconds.*

## 4.5.1 Installing the Smart Keypad



You can install up to 4 Smart Keypads in the system.

### Description of the Smart Keypad

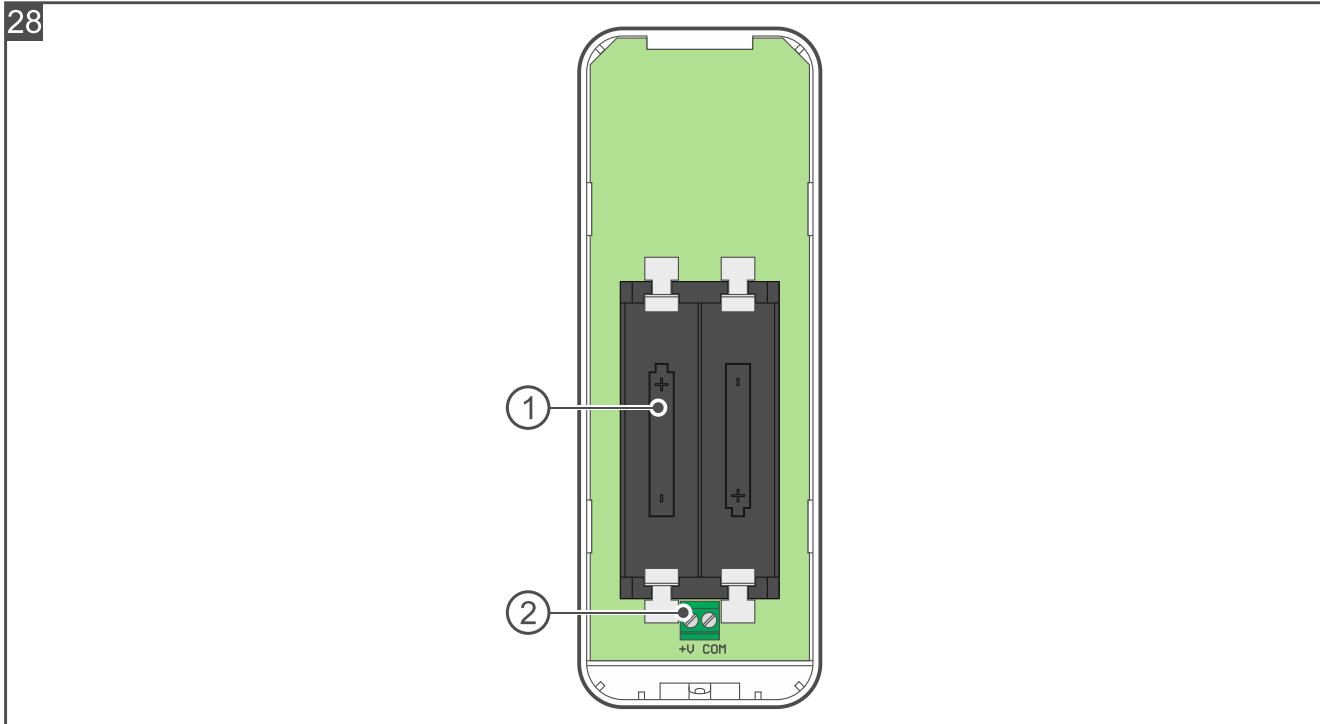

The figure shows the inside of the keypad.

- ① battery holder (2 x LR6 AA 1.5 V).
- ② terminals for connecting the APS-055 power supply (external power supply):
  - COM** - common ground.
  - V+** - 5...12 VDC power input.



Install two LR6 AA 1.5 V alkaline batteries in the keypad (they are not supplied with the keypad). We do not recommend installing rechargeable batteries. Optionally, you can connect the SATEL APS-055 power supply (external power supply) to the keypad. The APS-055 is a flush-mounted 5 VDC / 0.5 A power supply. When the power supply is connected to the keypad, the batteries are used only in case of loss of external power supply.

### Installation tips for the Smart Keypad

- The keypad should be installed indoors, in spaces with normal air humidity.
- Do not install the keypad outdoors.
- The place of installation should be readily accessible to the system users.
- To connect the APS-055 power supply, use flexible wires with a cross-section of 0.5-0.75 mm<sup>2</sup>.

### Mounting the Smart Keypad

1. Loosen the cover locking screw and open the keypad enclosure (Fig. 29). The enclosure opening tool, shown in the figure, is provided with the keypad.

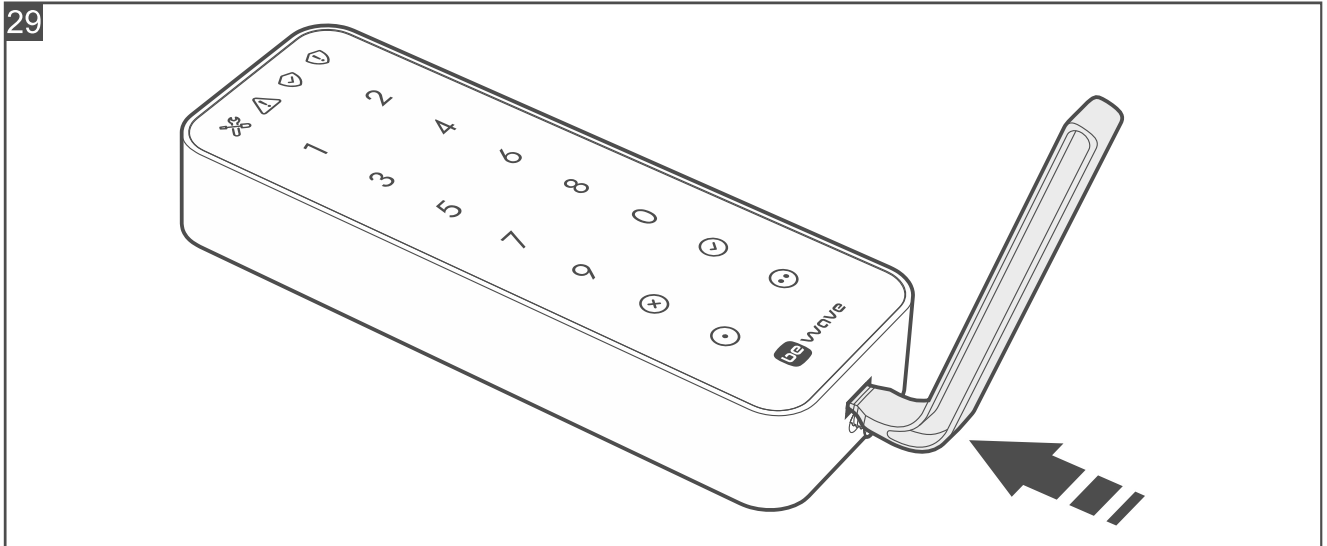

2. If the keypad is to be mounted on the wall using a double-sided mounting tape (Fig. 30):
  - stick the tape to the enclosure base.
  - if the APS-055 power supply is to be used, run the power wires through the opening in the enclosure base.
  - stick the enclosure base to the surface.
3. If the keypad is to be secured to the wall with screws (Fig. 31):
  - place the enclosure base against the wall and mark the location of mounting holes.
  - drill the holes in the wall for wall plugs (anchors). Use wall plugs specifically intended for the mounting surface (different for concrete or brick wall, different for plaster wall, etc.).
  - if the APS-055 power supply is to be used, run the power wires through the opening in the enclosure base.
  - secure the enclosure base to the wall with screws.



*If the keypad is to detect removal from the wall, secure it with screws.*

*The keypad must detect removal from the wall if it is to meet the requirements of Standard EN 50131 for Grade 2.*

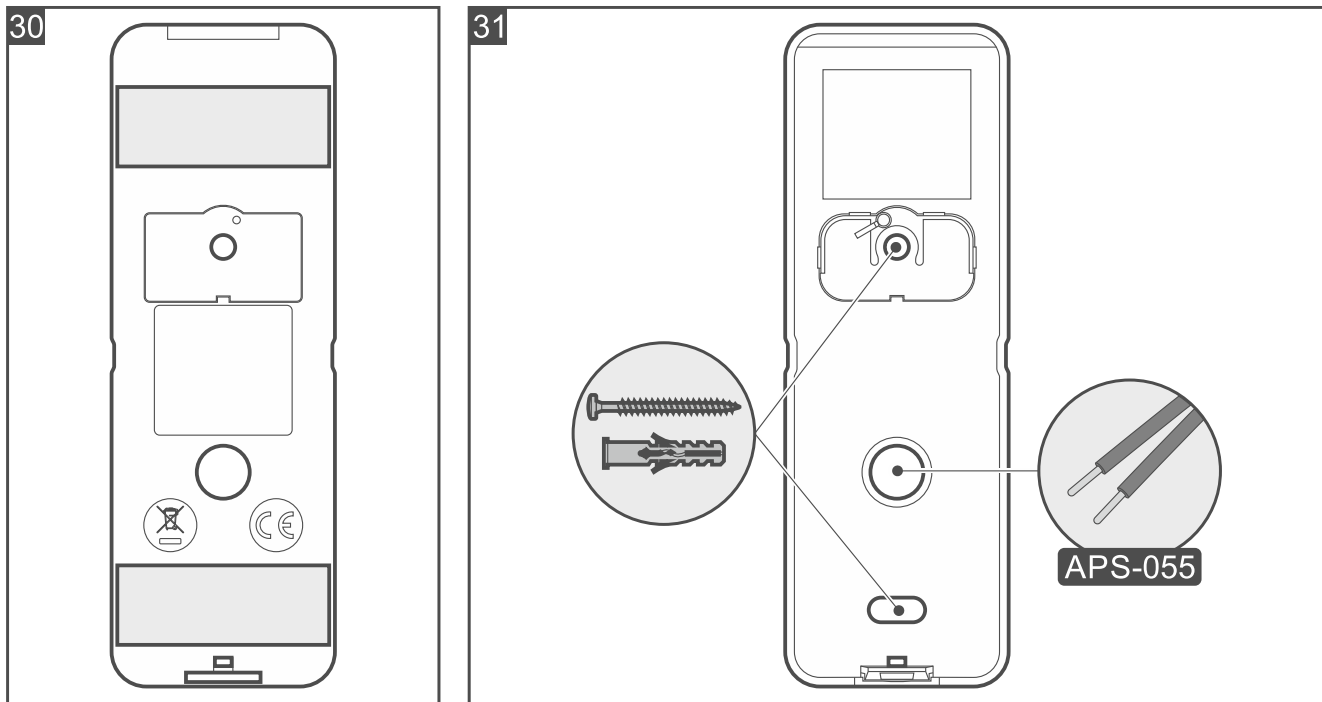

4. Start the Be Wave app and add the keypad to the system. When a request to turn on the device will be displayed, install two LR6 AA 1.5 V alkaline batteries in the keypad.
5. If the APS-055 power supply is to be used, screw the power wires to the +V and COM terminals (Fig. 28).
6. Close the keypad enclosure and lock it with a screw.

#### 4.5.2 Installing the Motion Detector, Motion Detector Pet and Motion Detector Plus

##### Installation tips for the Motion Detector, Motion Detector Pet and Motion Detector Plus

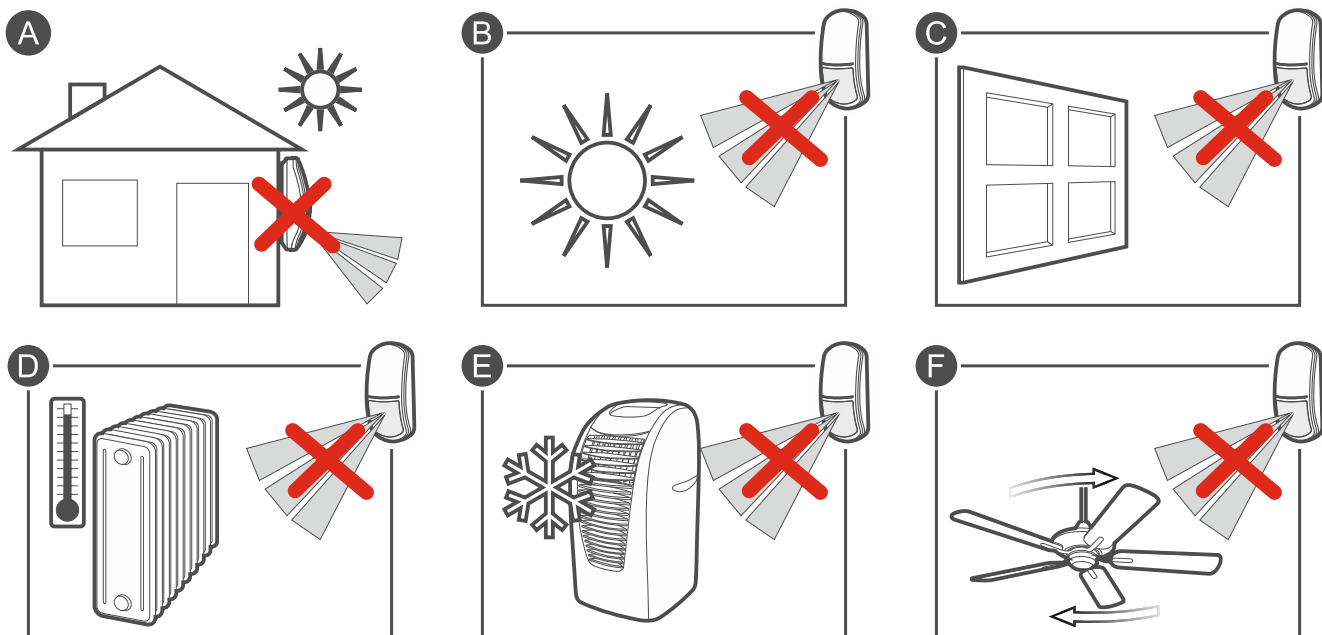

- The detector should be installed indoors, in spaces with normal air humidity.
- Do not install the detector outdoors (A).
- Do not aim the detector directly at sunlight or at surfaces reflecting sunlight (B).
- Do not aim the detector at a window because it may detect motion on the outside (C).

- Do not point the detector towards heat sources (D), air conditioners (E) or fans (F).
- No object should obstruct the detector's field of view.
- Install the detector at the recommended height:
  - Motion Detector and Motion Detector Plus: 2...2.4 m,
  - Motion Detector Pet: 2.4 m.



*The Motion Detector Pet is pet immune when it is mounted at 2.4 m height with no vertical tilt.*

### Mounting the Motion Detector, Motion Detector Pet and Motion Detector Plus



*The figures are for reference only. There are small differences between the detectors.*

1. Open the detector enclosure (Fig. 32).



*The inside of the cover and the electronics module of the Motion Detector Pet are marked with a blue circle. This makes it easier to identify the elements of the device.*

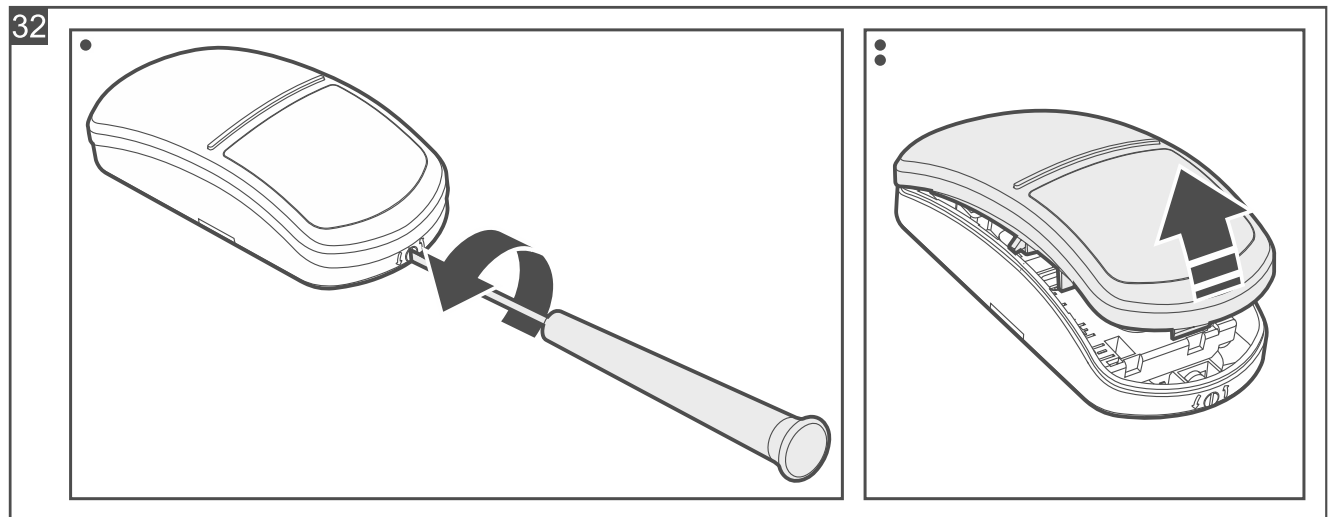

2. Press the catches and move the electronics module down, then remove it from the enclosure base (Fig. 33).

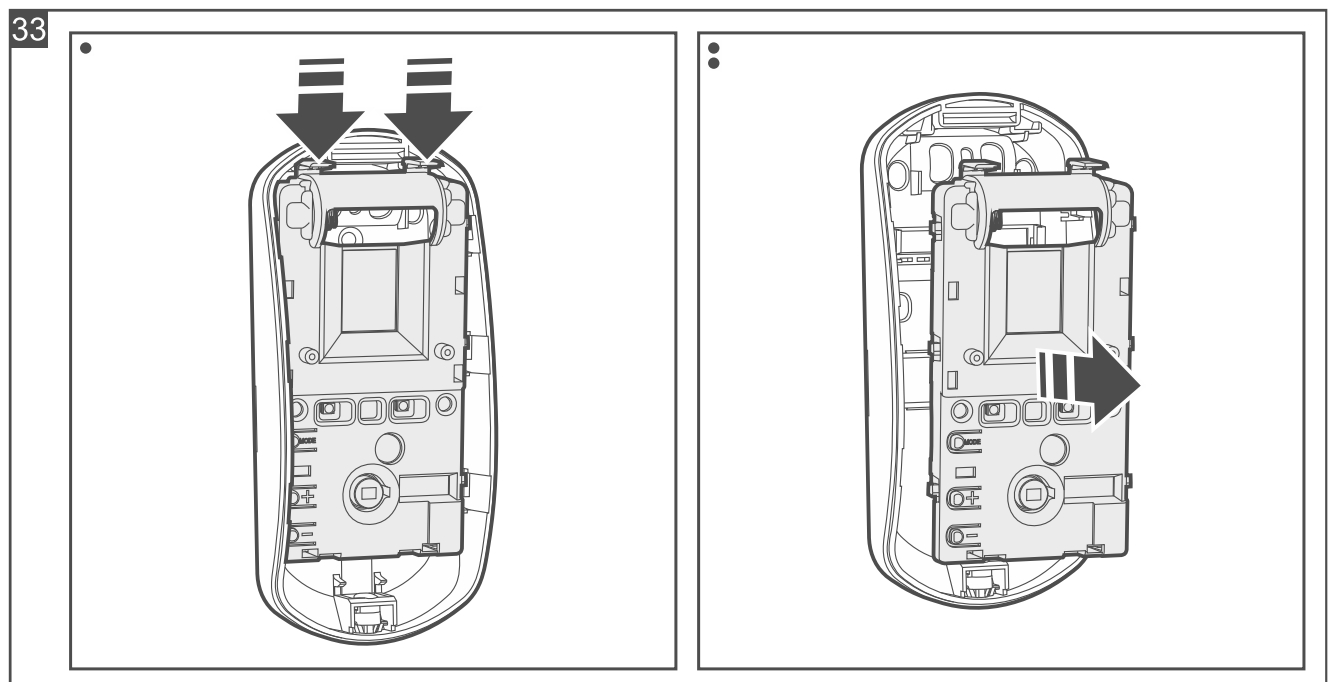

3. If the detector is to be mounted on the wall using a double-sided mounting tape (Fig. 34):
- stick the tape to the enclosure base. Adjust the shape and position of the tape depending on the place of installation.
  - stick the enclosure base to the wall.

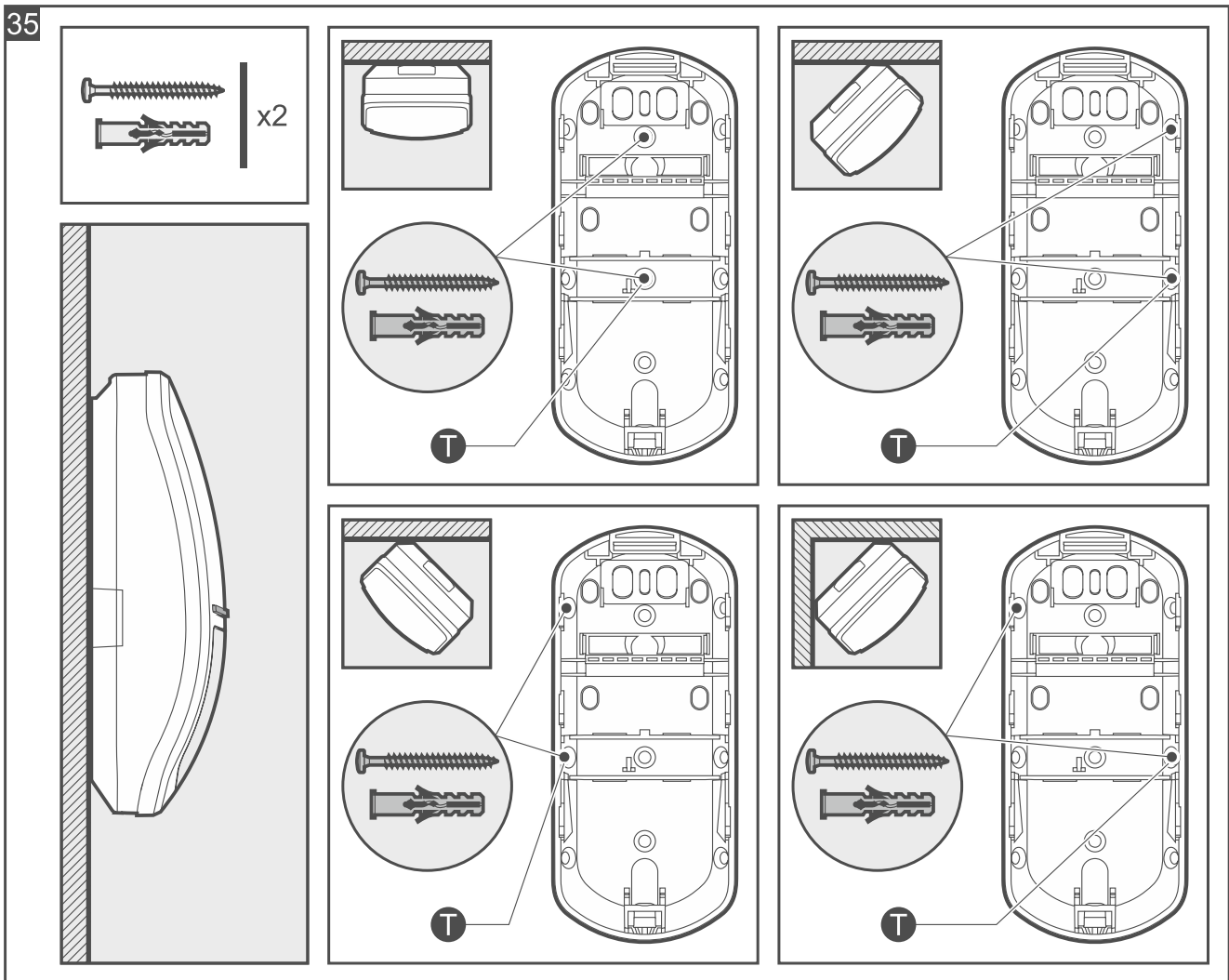
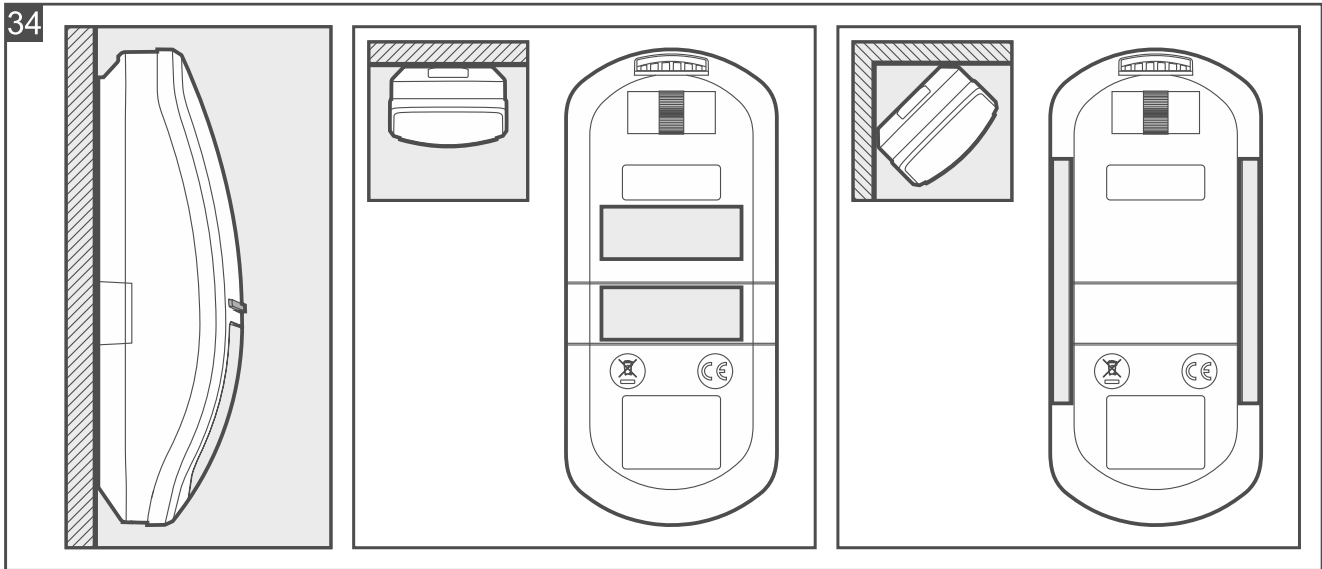

4. If the detector is to be secured to the wall with screws (Fig. 35) or to a bracket mounted on the wall or ceiling (Fig. 36):
- make screw holes in the enclosure base.

- drill the holes in the wall for wall plugs (anchors). The wall plugs provided with the detector are intended for concrete or brick. For other types of surface (drywall, styrofoam), use other appropriately selected wall plugs.
- secure the enclosure base to the wall or a bracket with screws.



*If the detector is to detect removal from the surface, secure the detector to the wall with screws (do not use a bracket). In order for the detector to detect removal from the surface, fasten the screws in places marked with the **T** symbol in Fig. 35.*

*The detector must detect removal from the surface if it is to meet the requirements of Standard EN 50131 for Grade 2.*

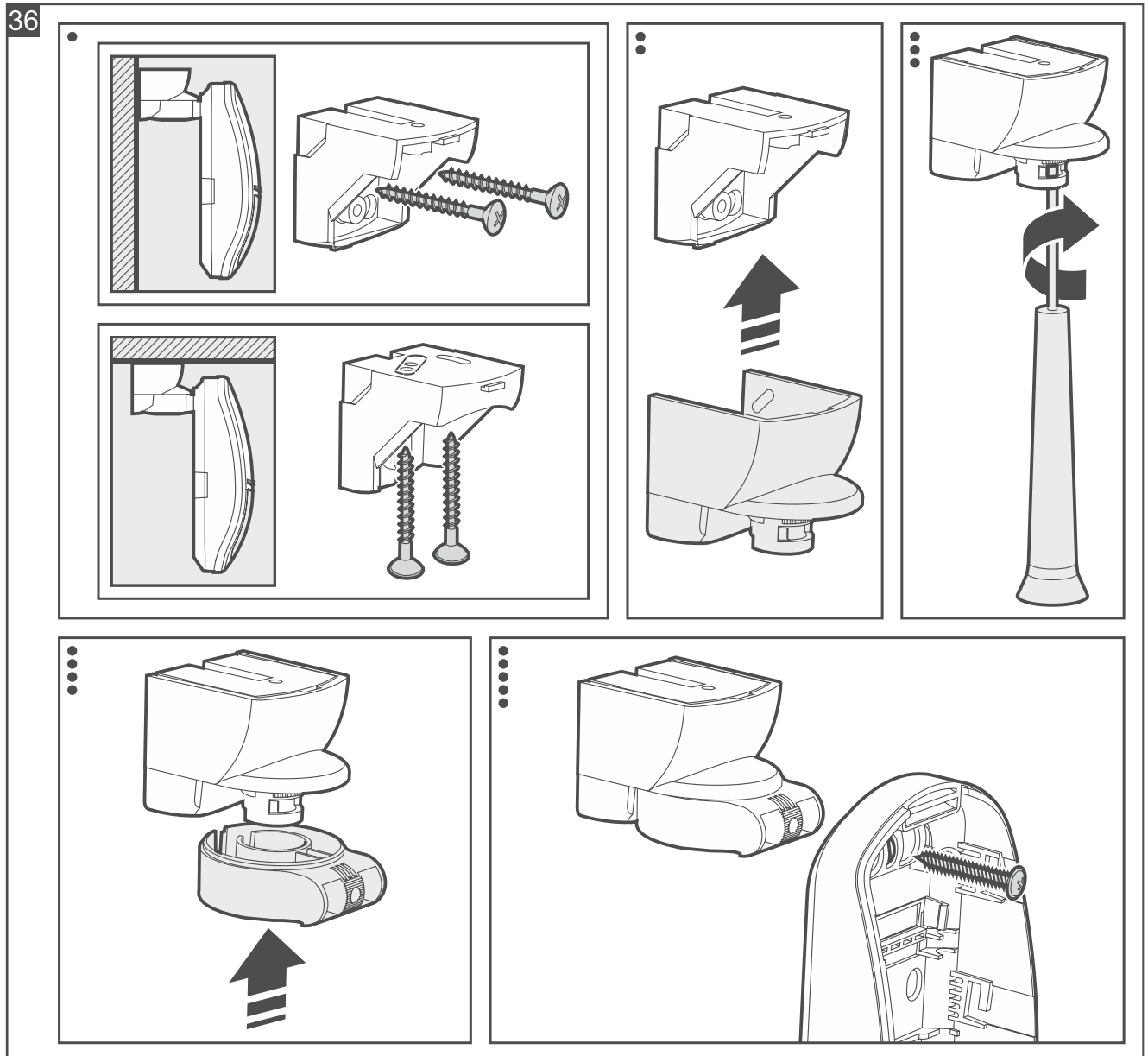

5. Use the knob on the cover to enable / disable the creep zone protection (not applicable to the Motion Detector Pet). Fig. 37 A – creep zone protected. Fig. 37 B – creep zone not protected.

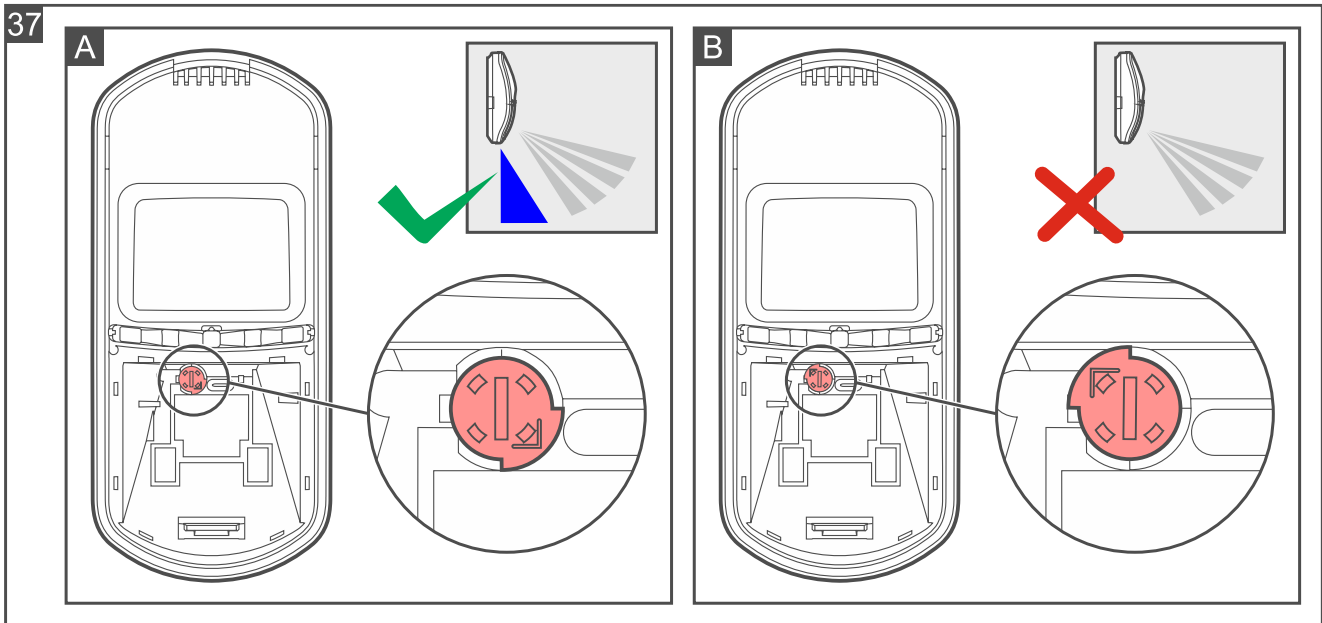

6. Start the Be Wave app and add the detector to the system. When a request to turn on the device will be displayed, install the battery in the detector.
7. Place the electronics module in the enclosure base and then move it up to lock it.
8. Close the enclosure.

### 4.5.3 Installing the Motion Detector Cam

#### Installation tips for the Motion Detector Cam

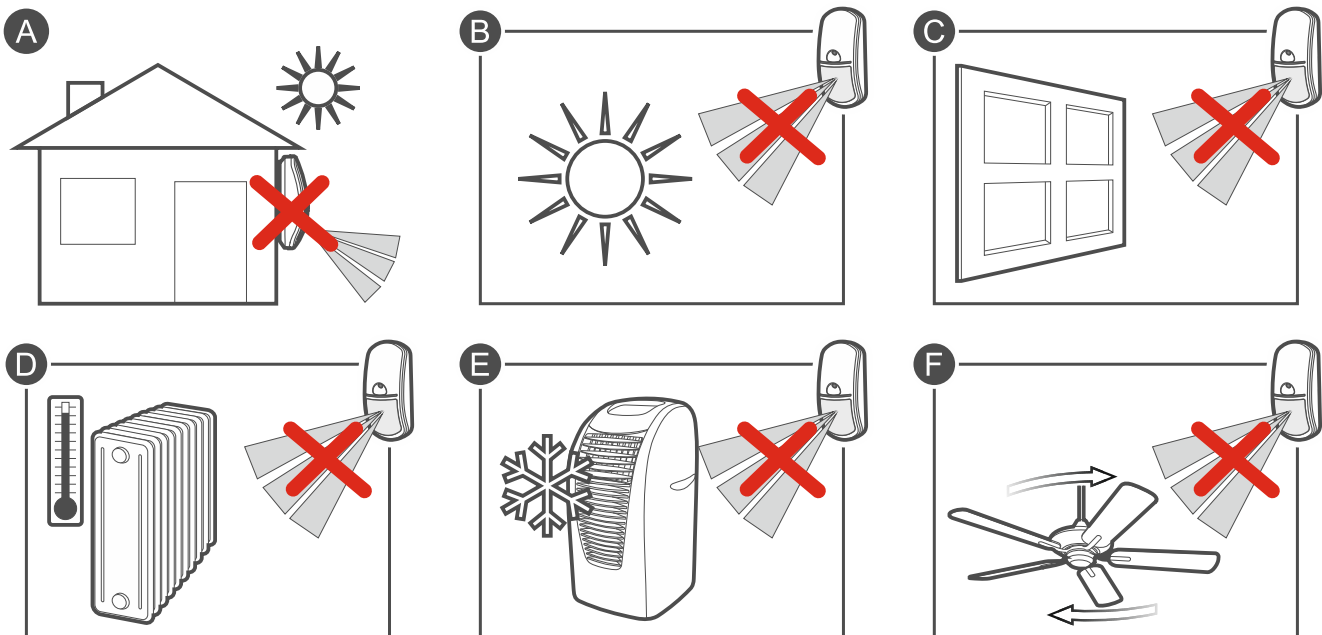

- The detector should be installed indoors, in spaces with normal air humidity.
- Do not install the detector outdoors (A).
- Do not aim the detector directly at sunlight or at surfaces reflecting sunlight (B).
- Do not aim the detector at a window because it may detect motion on the outside (C).
- Do not point the detector towards heat sources (D), air conditioners (E) or fans (F).

- No object should obstruct the detector's field of view.
- Install the detector at 2...2.4 height.
- To connect the APS-055 power supply, use flexible wires with a cross-section of 0.5-0.75 mm<sup>2</sup>.

### Description of the Motion Detector Cam

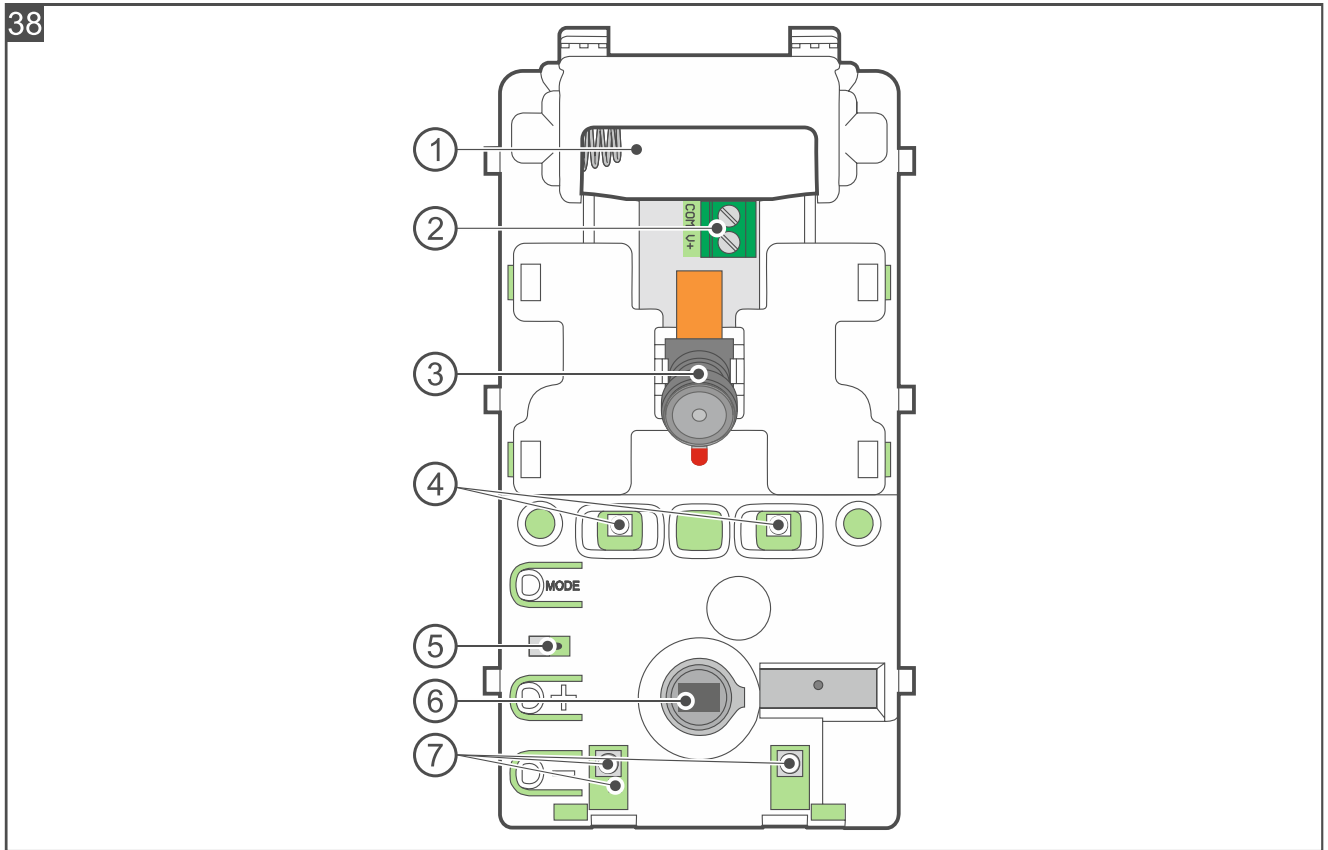

The figure shows the detector electronics module.

- ① battery holder (CR123A 3 V).
- ② terminals for connecting the APS-055 power supply (external power supply):
  - COM** - common ground.
  - V+** - 5...12 V DC power input.



*Install a CR123A 3 V battery in the detector. Optionally, you can connect the SATEL APS-055 power supply (external power supply) to the detector. The APS-055 is a flush-mounted 5 VDC / 0.5 A power supply. When the power supply is connected to the detector, the battery is used only in case of loss of external power supply.*

*If the detector is powered by the external power supply, temperature data from the detector requires correction.*

- ③ camera.
- ④ LEDs.
- ⑤ tamper protection against enclosure opening.
- ⑥ PIR sensor (dual element pyrosensor).
- ⑦ infrared illuminator elements.

## Mounting the Motion Detector Cam

1. Open the detector enclosure (Fig. 39).

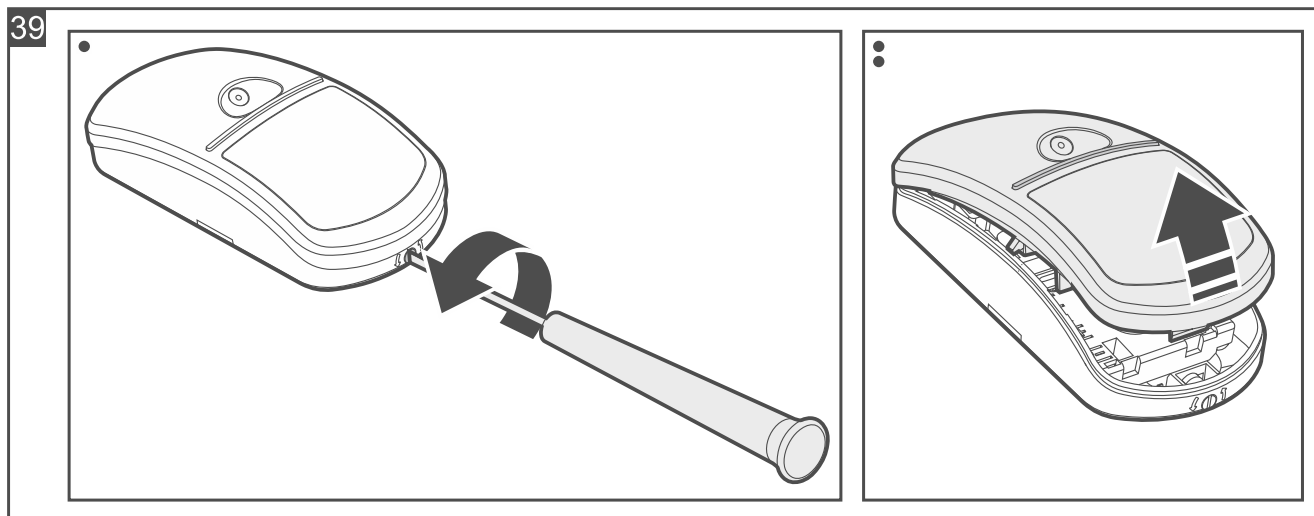

2. Press the catches and move the electronics module down, then remove it from the enclosure base (Fig. 40).

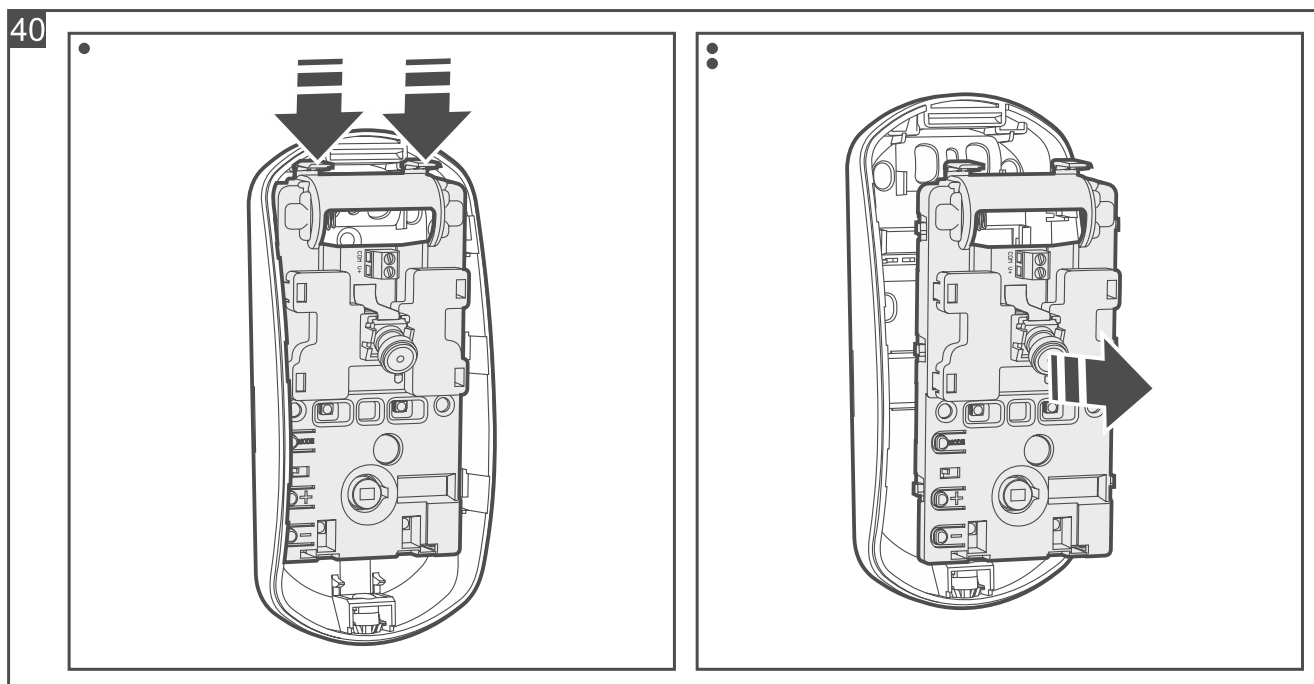

3. If the APS-055 power supply is to be connected to the detector, make a hole in the enclosure base for the power wires (Fig. 41).

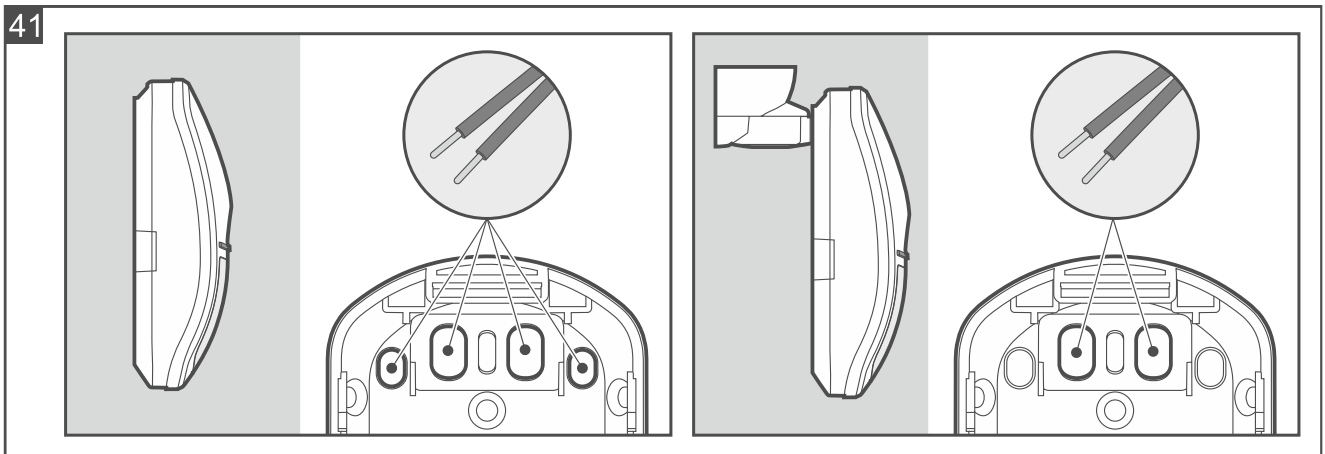

4. If the detector is to be mounted on the wall using a double-sided mounting tape (Fig. 42):
- stick the tape to the enclosure base. Adjust the shape and position of the tape depending on the place of installation.
  - if the APS-055 power supply is to be used, run the power wires through the hole you made in the enclosure base.
  - stick the enclosure base to the wall.

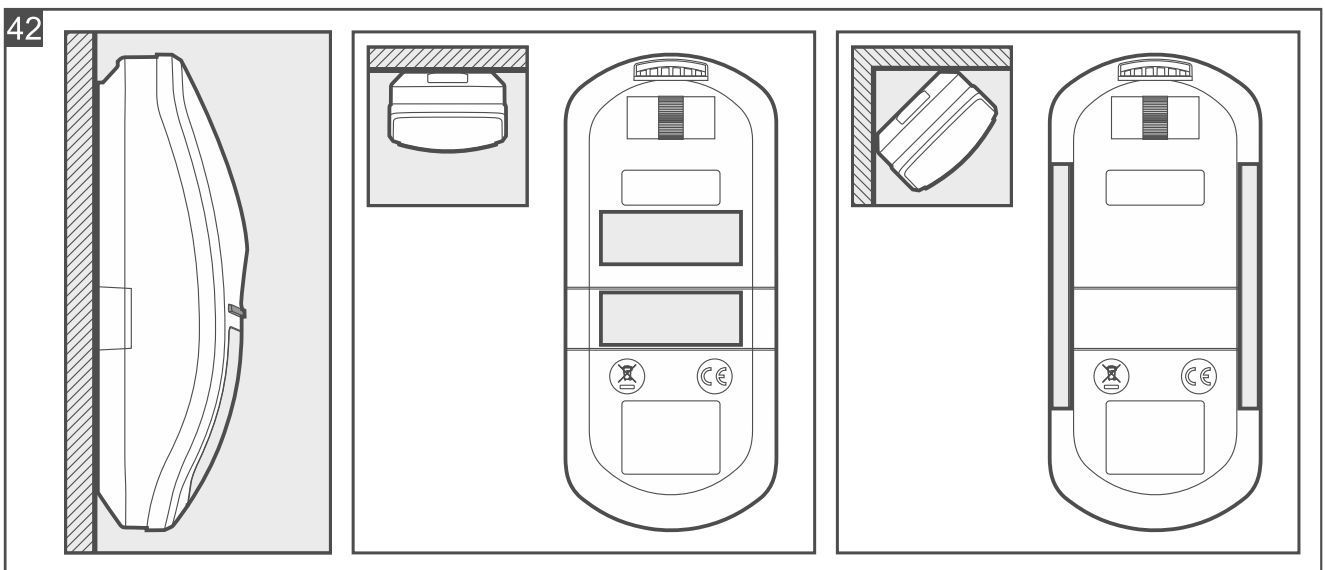

5. If the detector is to be secured to the wall with screws (Fig. 43) or to a bracket mounted on the wall or ceiling (Fig. 44):
- make screw holes in the enclosure base.
  - drill the holes in the wall for wall plugs (anchors). The wall plugs provided with the detector are intended for concrete or brick. For other types of surface (drywall, styrofoam), use other appropriately selected wall plugs.
  - if the APS-055 power supply is to be used, run the power wires through the hole you made in the enclosure base. If you are using a bracket, run the wires through the openings in the bracket.
  - secure the enclosure base to the wall or a bracket with screws.



*If the detector is to detect removal from the surface, secure the detector to the wall with screws (do not use a bracket). In order for the detector to detect removal from the surface, fasten the screws in places marked with the **T** symbol in Fig. 43.*

The detector must detect removal from the surface if it is to meet the requirements of Standard EN 50131 for Grade 2.

43

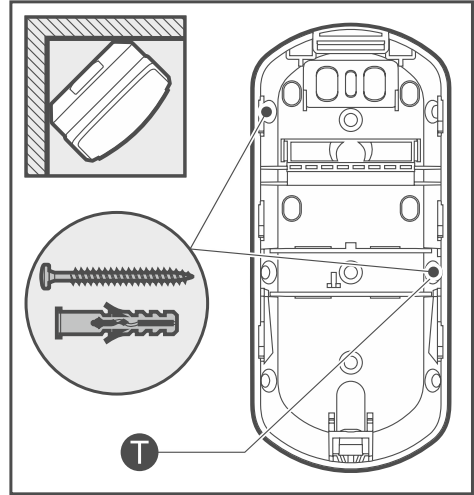
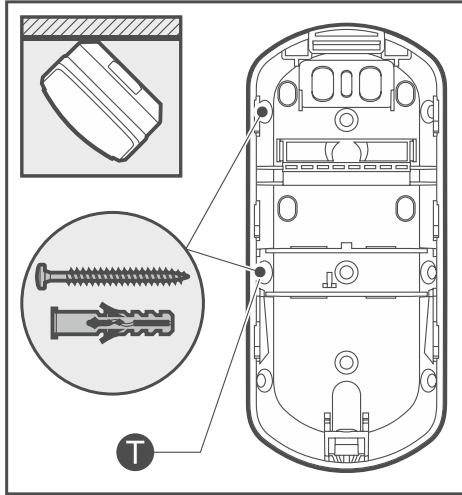
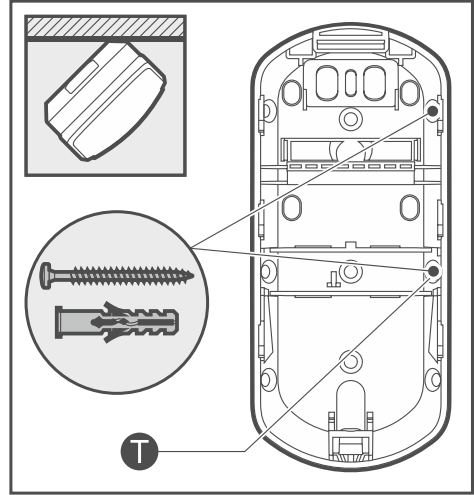
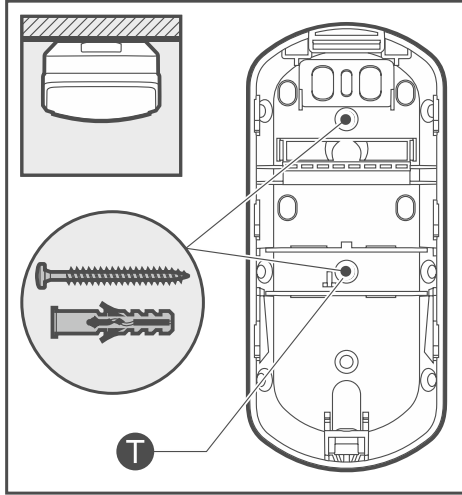
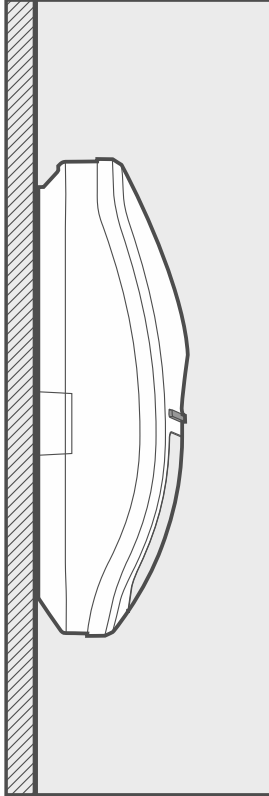
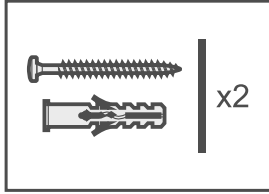

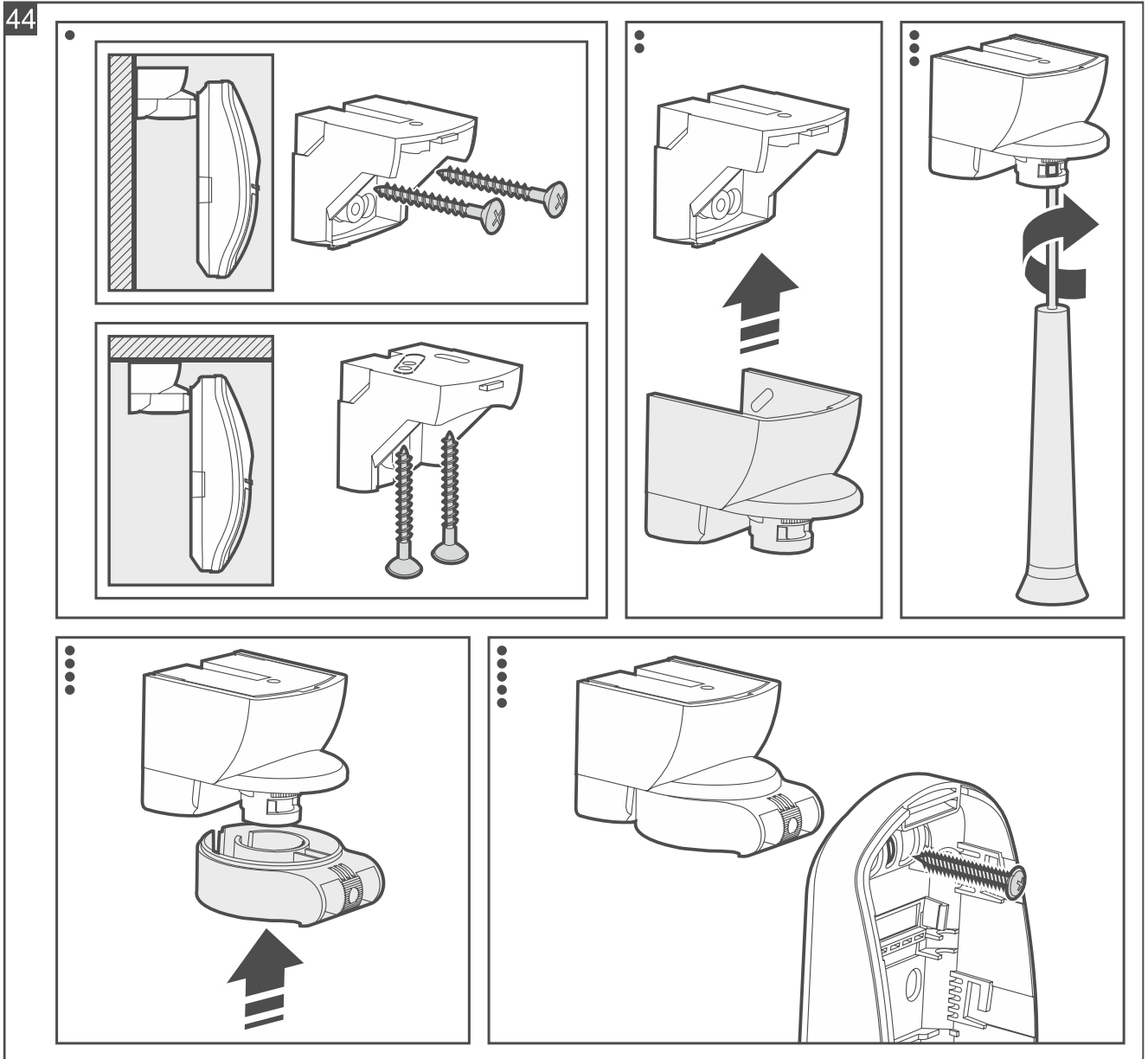

6. Use the knob on the cover to enable / disable the creep zone protection. Fig. 45 A – creep zone protected. Fig. 45 B – creep zone not protected.

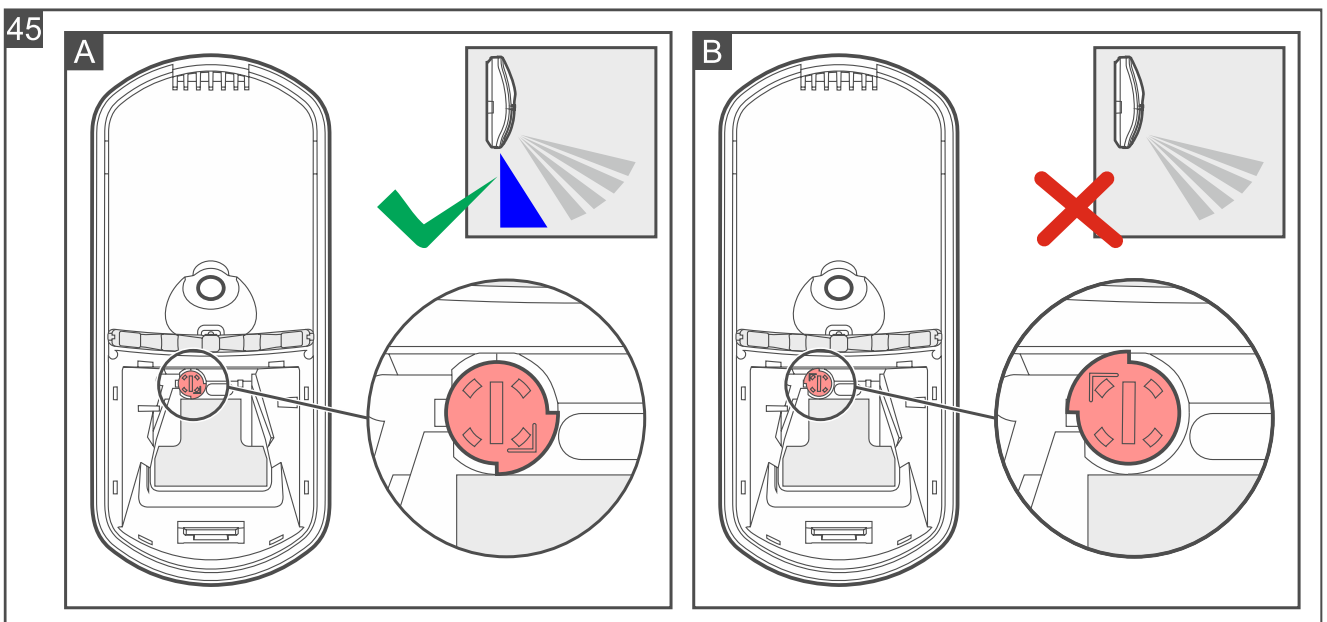

7. Start the Be Wave app and add the detector to the system. When a request to turn on the device will be displayed, install the battery in the detector.
8. Place the electronics module in the enclosure base and then move it up to lock it.
9. If the APS-055 power supply is to be used, screw the power wires to the V+ and COM terminals (Fig. 46).

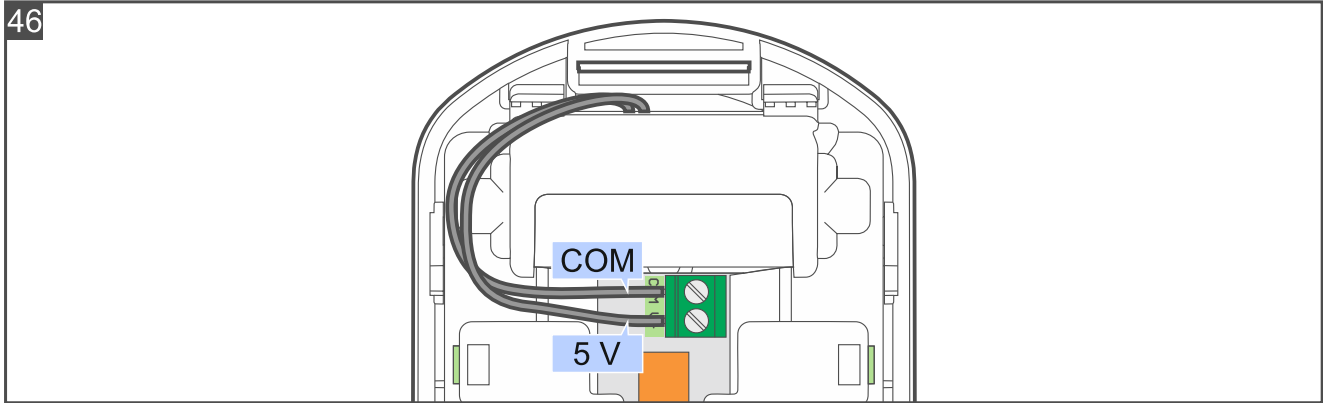

10. Remove the protective film from the camera lens (Fig. 47).

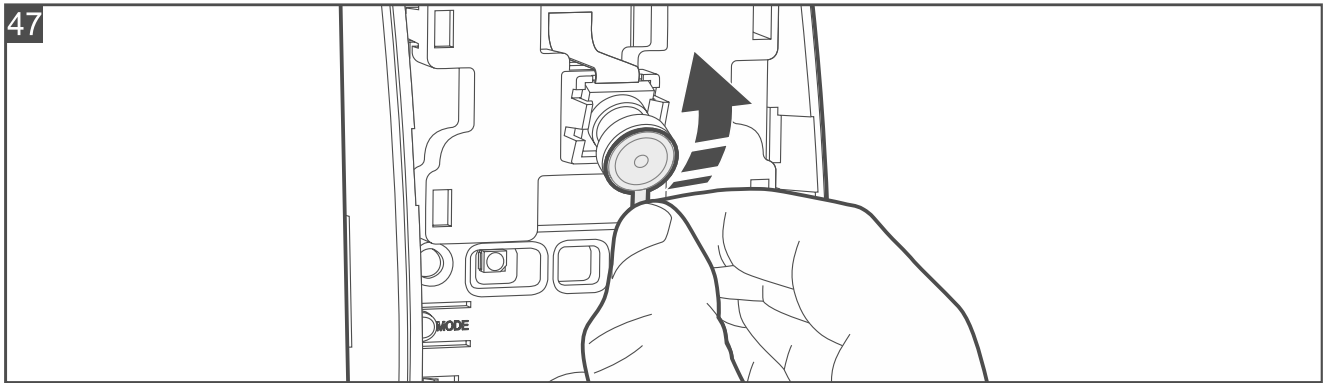

11. Close the enclosure.

#### 4.5.4 Installing the Outdoor Motion Detector

##### Installation tips for the Outdoor Motion Detector

- Do not aim the detector directly at sunlight or at surfaces reflecting sunlight.
- Do not point the detector towards heat sources, air conditioners or fans.
- Objects that can be moved by the wind (e.g. branches, bushes, clotheslines, etc.) should be at least 3 m from the detector.
- No object should obstruct the detector's field of view.
- Install the detector at 2.4 m height.



*The Outdoor Motion Detector is pet immune when it is mounted at 2.4 m height with no vertical tilt.*

### Mounting the Outdoor Motion Detector

1. Open the detector enclosure (Fig. 48).

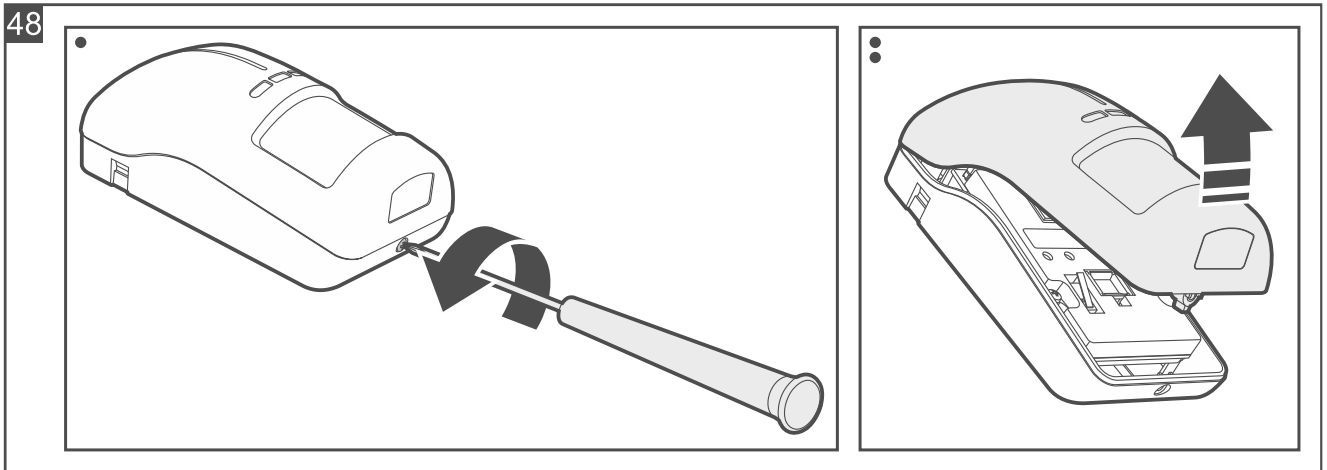

2. Remove the electronics module (Fig. 49).

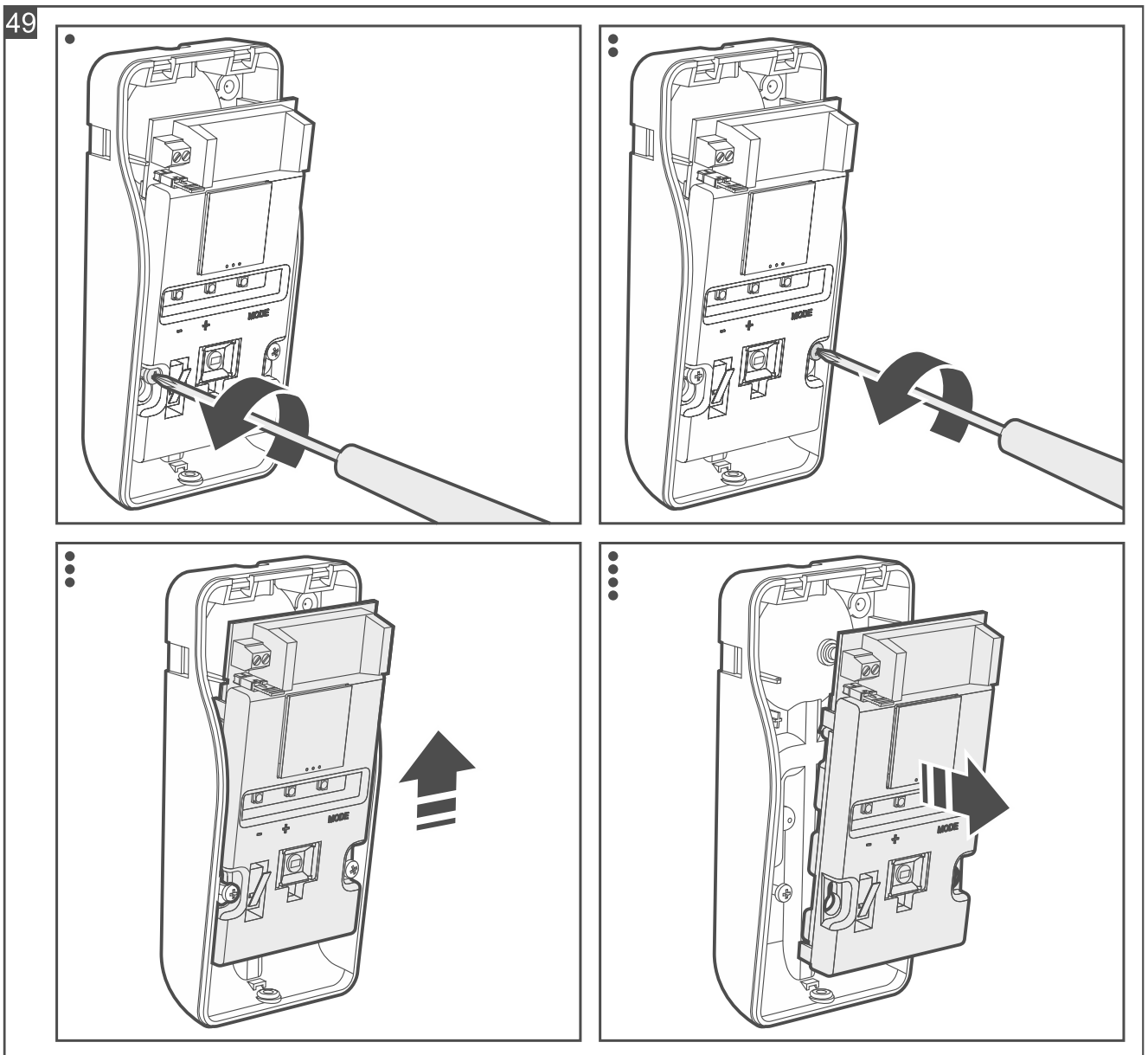

3. Secure the enclosure base with screws to the wall (Fig. 50), to the angle bracket (see “Angle bracket mounting”) or to the ball bracket (see “Ball bracket mounting”). Use wall

plugs specifically intended for the mounting surface (different for concrete or brick wall, different for plaster wall, etc.).



*In order for the detector to detect removal from the surface / bracket, fasten the screws in places marked with the **T** symbol in the figure.*

*The detector must detect removal from the surface / bracket if it is to meet the requirements of Standard EN 50131 for Grade 2.*

*The brackets are sold separately. The BRACKET C bracket set includes the angle bracket and the ball bracket.*

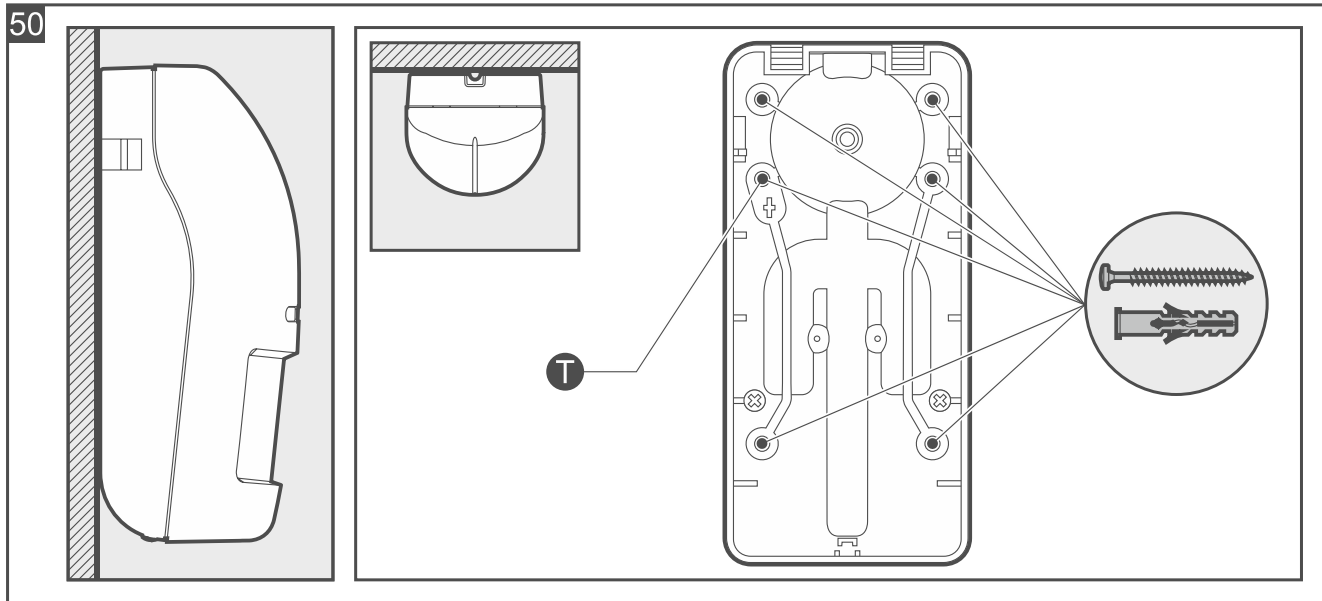

4. Place the electronics module in the enclosure base and secure it with screws.
5. If you mounted the detector on a bracket or used an additional tamper switch (requirement of Standard EN 50131 for Grade 2):
  - screw the tamper switch wires to the TMP terminals (black wire to one terminal, blue wire to the other),
  - remove the jumper from the pins below the terminals.
6. Start the Be Wave app and add the detector to the system. When a request to turn on the device will be displayed, install the battery in the detector. Secure the battery with the clip provided in the box.
7. Close the enclosure and lock it with a screw.

### **Angle bracket mounting**



*If the detector is not to detect removal of the bracket from the surface, you do not have to attach the additional tamper switch (skip the steps regarding its installation).*

*The detector must detect removal of the bracket from the surface if it is to meet the requirements of Standard EN 50131 for Grade 2.*

1. Place the angle bracket against the wall and mark the location of the mounting holes.
2. Drill the holes in the surface for wall plugs (anchors). Use wall plugs specifically intended for the mounting surface (different for concrete or brick wall, different for plaster wall, etc.).
3. Secure the angle bracket to the surface with screws.
4. Attach the additional tamper switch:
  - screw the holder to the tamper switch (Fig. 51-I),

- screw the holder with the tamper switch to the enclosure base (Fig. 51-II).



The figure shows how to attach the tamper switch in one of the two available positions. When selecting the position, consider the way of angle bracket mounting. If the tamper switch is to be attached in the other position, screw the holder to the tamper switch on the other side.

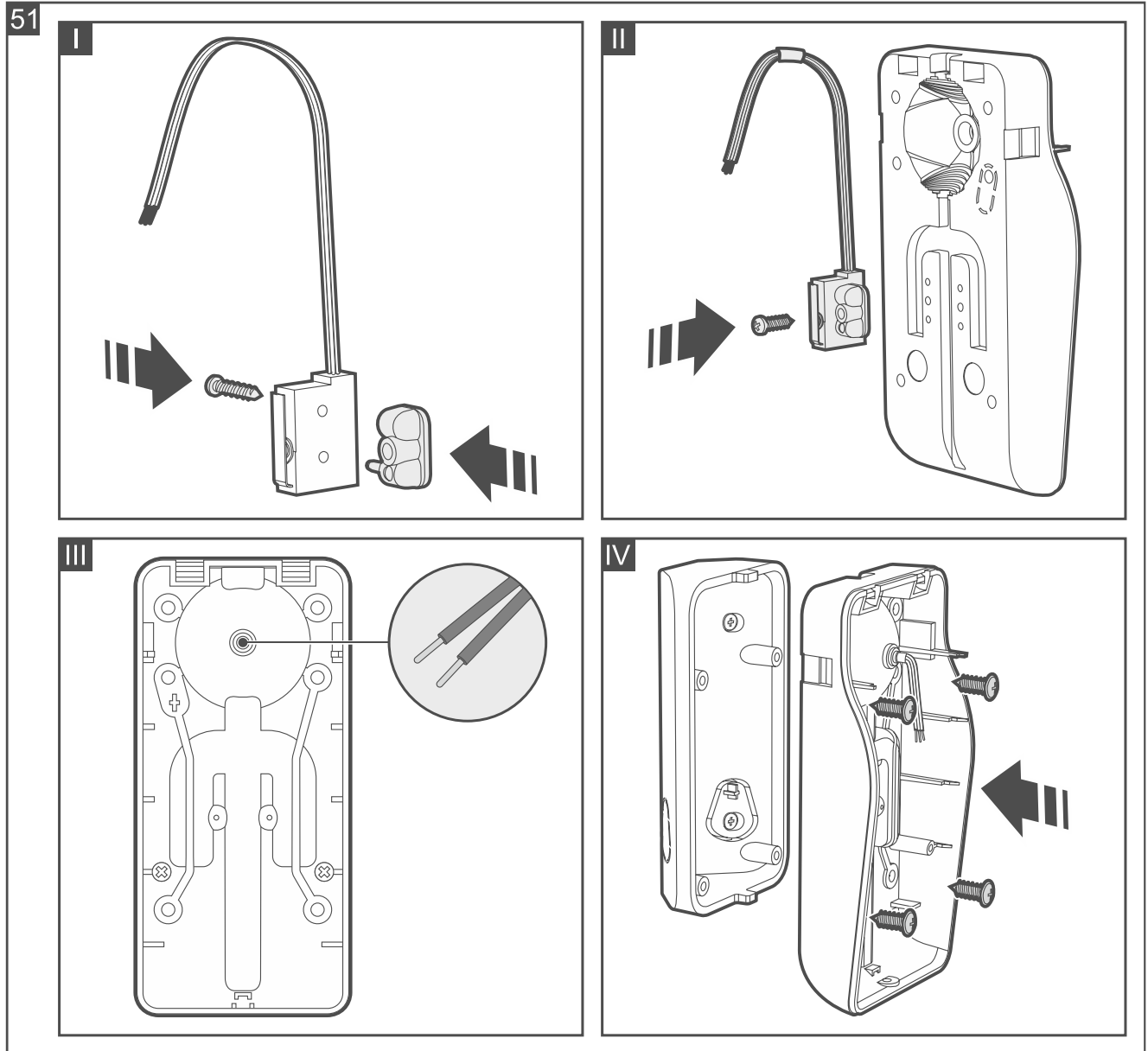

5. Make an opening for the tamper switch wires in the enclosure base (Fig. 51-III).
6. Run the tamper switch wires through the opening.



It is recommended that the tamper switch wires be placed in a heat shrink tubing. It reduces the risk of getting water into the enclosure.

7. Secure the enclosure base to the bracket with screws (Fig. 51-IV).

### Ball bracket mounting



If the detector is not to detect removal of the bracket from the surface, you do not have to attach the additional tamper switch (skip the steps regarding its installation).

The detector must detect removal of the bracket from the surface if it is to meet the requirements of Standard EN 50131 for Grade 2.

1. Attach the additional tamper switch:

- screw the holder to the tamper switch (Fig. 52-I),
- attach the unit making the surface bigger on the tamper switch (Fig. 52-II),
- screw the holder with the tamper switch to the ball bracket base (Fig. 52-III).

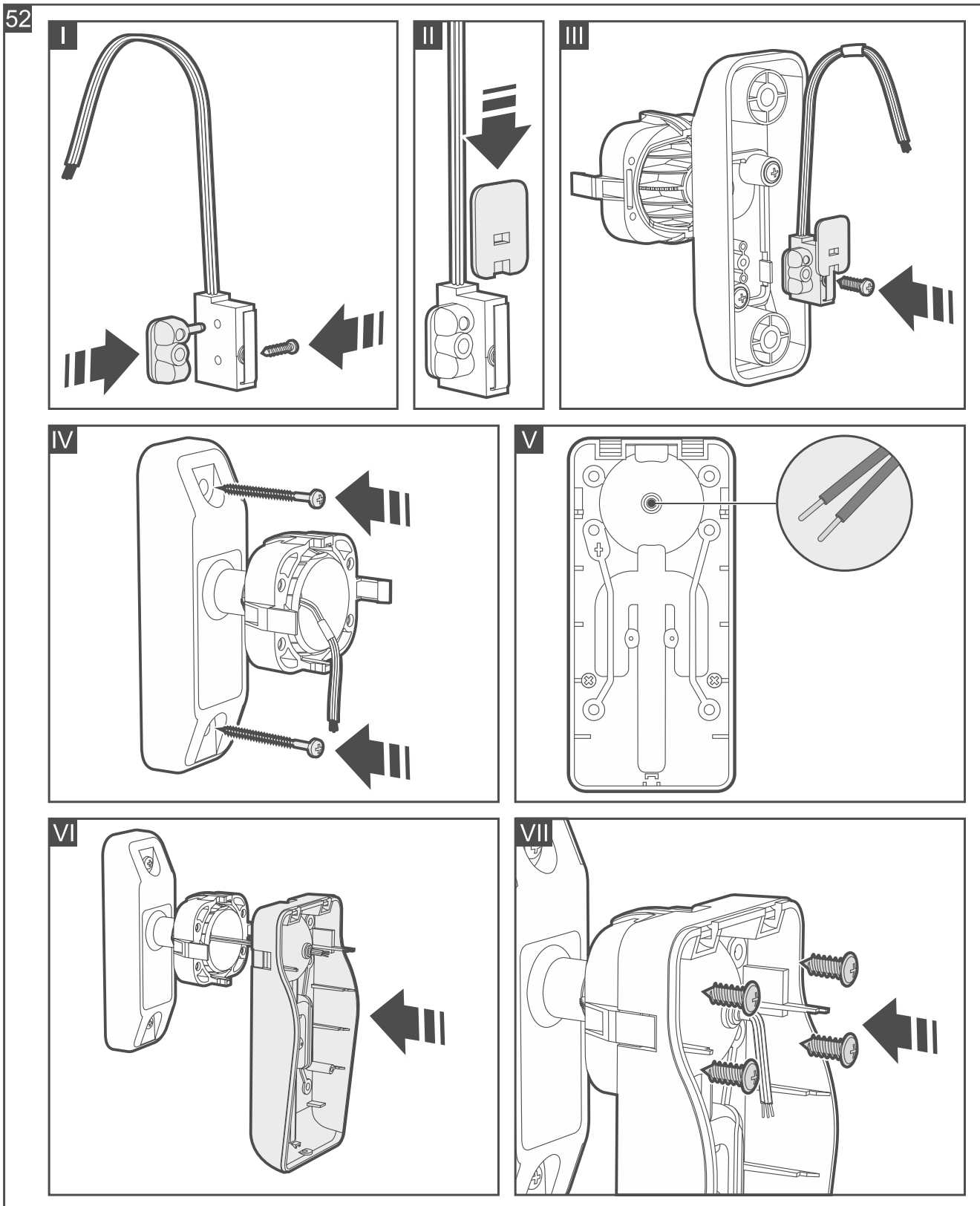

2. Run the tamper switch wires through the opening in the handle of the bracket.
3. Place the ball bracket against the wall and mark the location of the mounting holes.

4. Drill the holes in the surface for wall plugs (anchors). Use wall plugs specifically intended for the mounting surface (different for concrete or brick wall, different for plaster wall, etc.).
5. Secure the ball bracket to the surface with screws (Fig. 52-IV).
6. Make an opening for the tamper switch wires in the enclosure base (Fig. 52-V).
7. Run the tamper switch wires through the opening.

**i** *It is recommended that the tamper switch wires be placed in a heat shrink tubing. It reduces the risk of getting water into the enclosure.*

8. Secure the enclosure base to the bracket with screws (Fig. 52-VII).

#### 4.5.5 Installing the Curtain Detector

##### Installation tips for the Curtain Detector

- The detector should be installed indoors, in spaces with normal air humidity.
- Do not install the detector outdoors (A).
- Do not aim the detector directly at sunlight or at surfaces reflecting sunlight.
- Do not point the detector towards heat sources (B), air conditioners (C) or fans (D).
- No object should obstruct the detector's field of view.

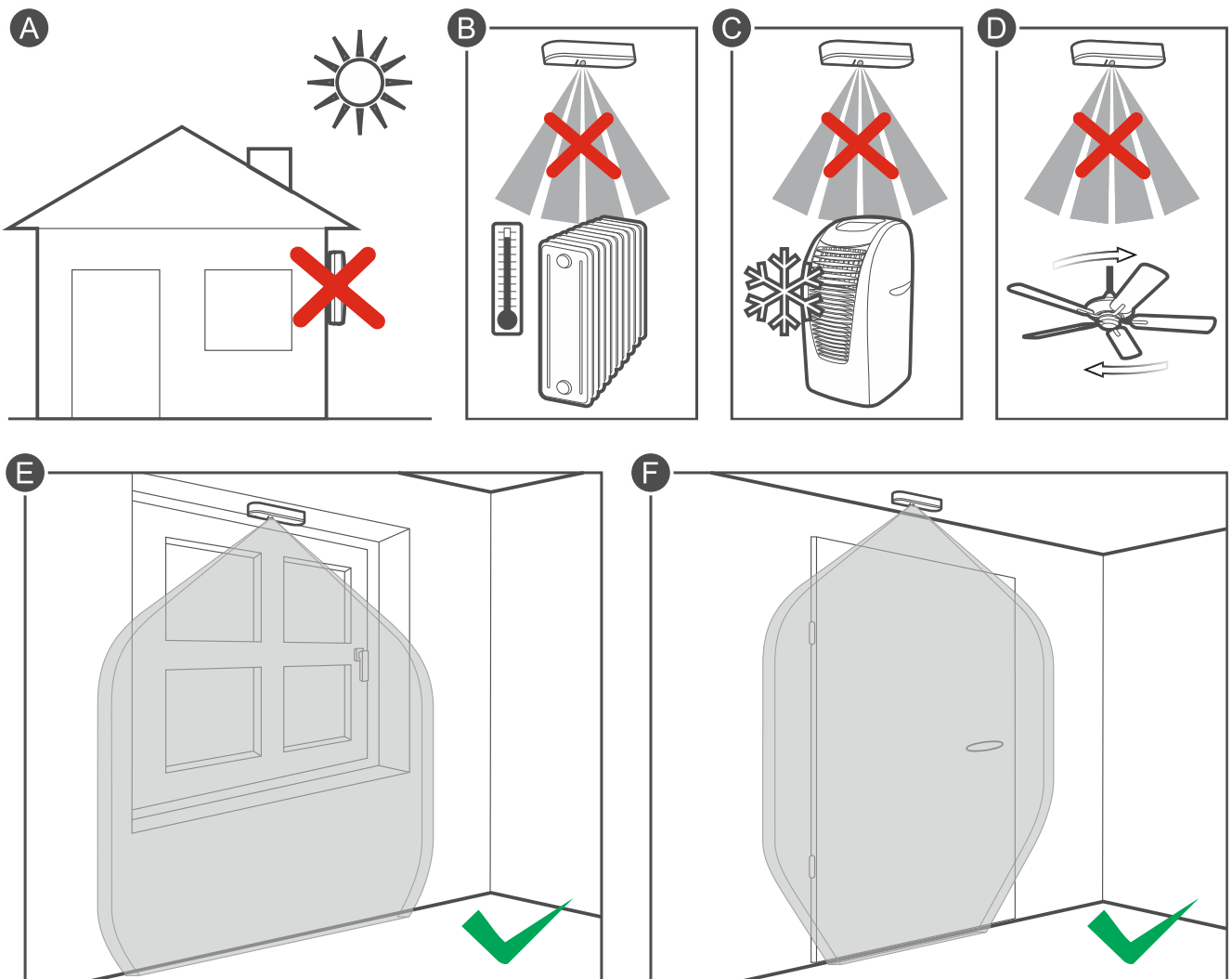

##### Mounting the Curtain Detector

1. Open the detector enclosure (Fig. 53). The enclosure opening tool, shown in the figure, is provided with the detector.

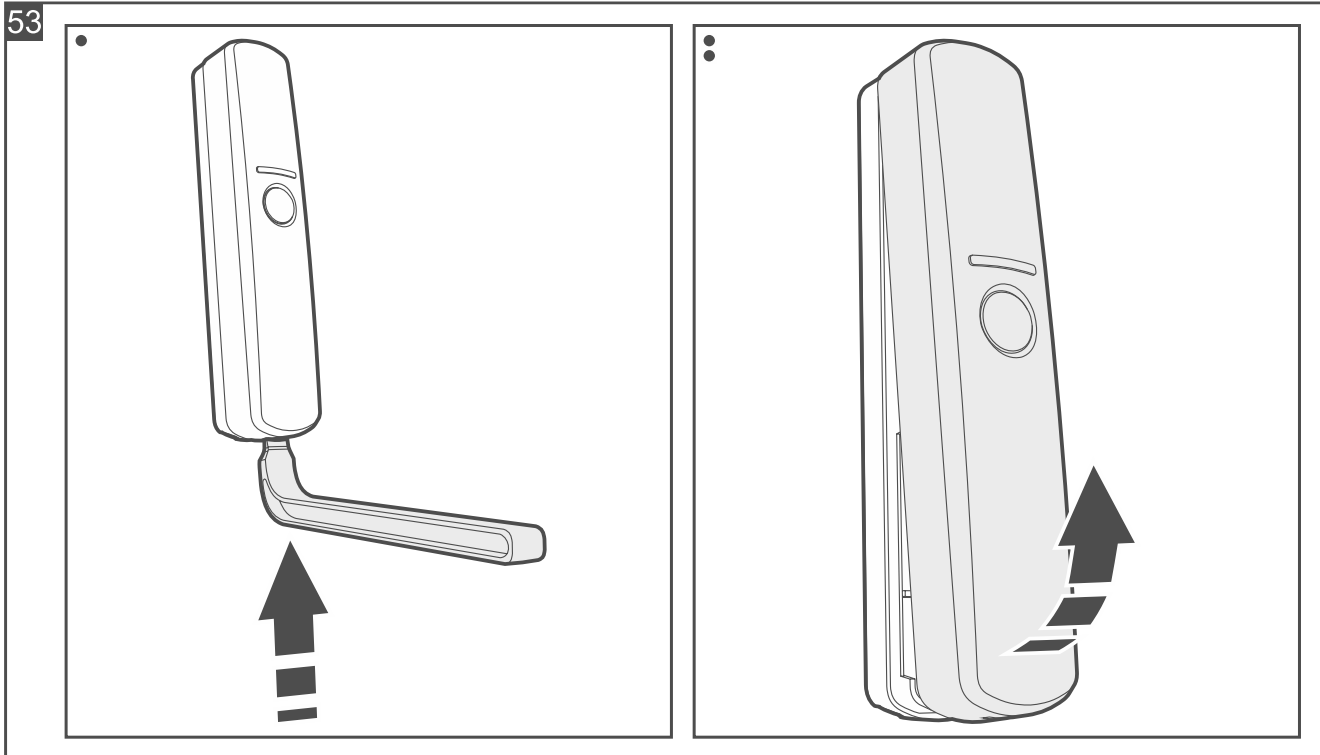

2. If the detector is to be mounted on the surface using a double-sided mounting tape (Fig. 54):

- stick the tape to the enclosure base.
- stick the enclosure base to the surface.

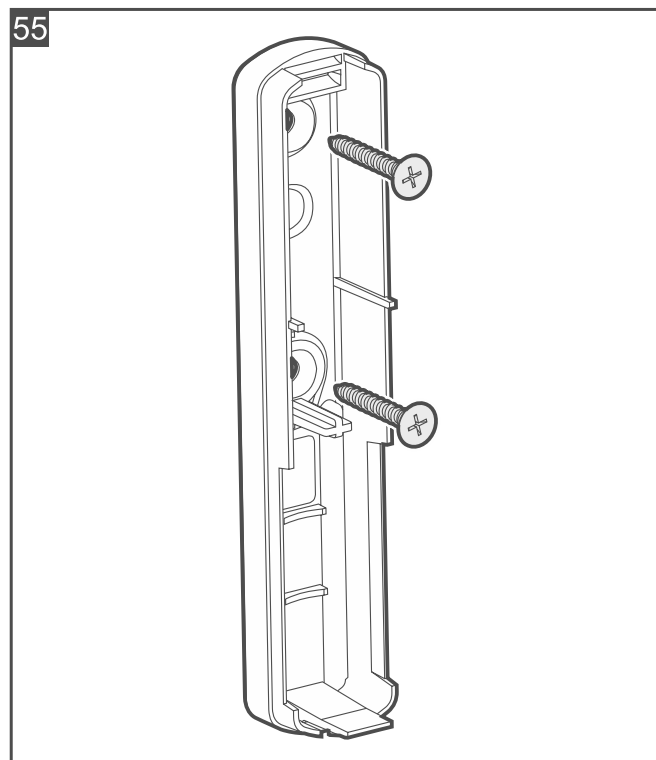
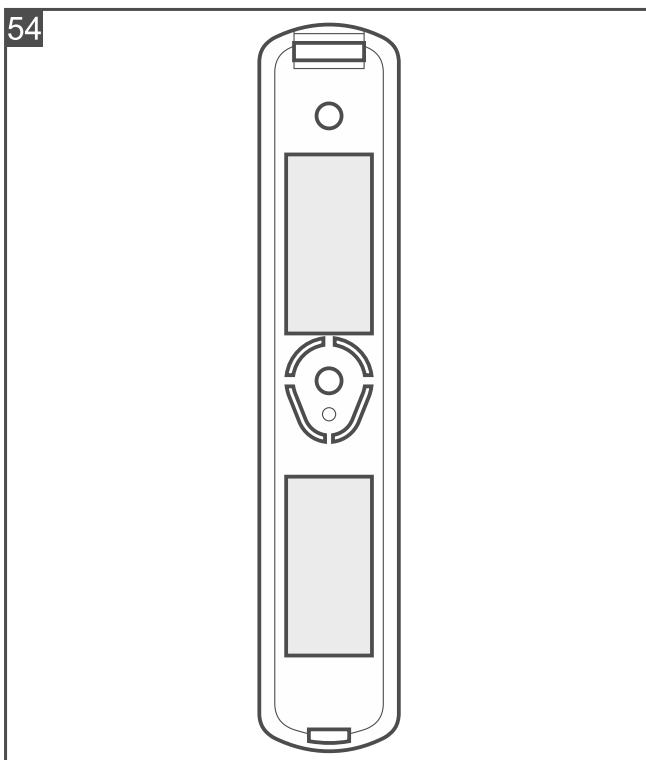

3. If the detector is to be mounted on the surface with screws:

- place the enclosure base against the surface and mark the location of the mounting holes.
- drill the holes in the surface for wall plugs (anchors). The wall plugs provided with the detector are intended for concrete or brick. For other types of surface (drywall, styrofoam), use other appropriately selected wall plugs.

- secure the enclosure base to the surface with screws (Fig. 55).



*If the detector is to detect removal from the surface, secure the detector with screws.*

*The detector must detect removal from the surface if it is to meet the requirements of Standard EN 50131 for Grade 2.*

4. Start the Be Wave app and add the detector to the system. When a request to turn on the device will be displayed, install the battery in the detector.
5. Close the enclosure.

#### 4.5.6 Installing the Outdoor Curtain Detector

##### Installation tips for the Outdoor Curtain Detector

- Do not aim the detector directly at sunlight or at surfaces reflecting sunlight.
- Do not point the detector towards heat sources, air conditioners or fans.
- Objects that can be moved by the wind (e.g. branches, bushes, clotheslines, etc.) should be at least 3 m from the detector.
- No object should obstruct the detector's field of view.
- Install the detector at 2.4 m height.

##### Mounting the Outdoor Curtain Detector

1. Open the detector enclosure (Fig. 56).

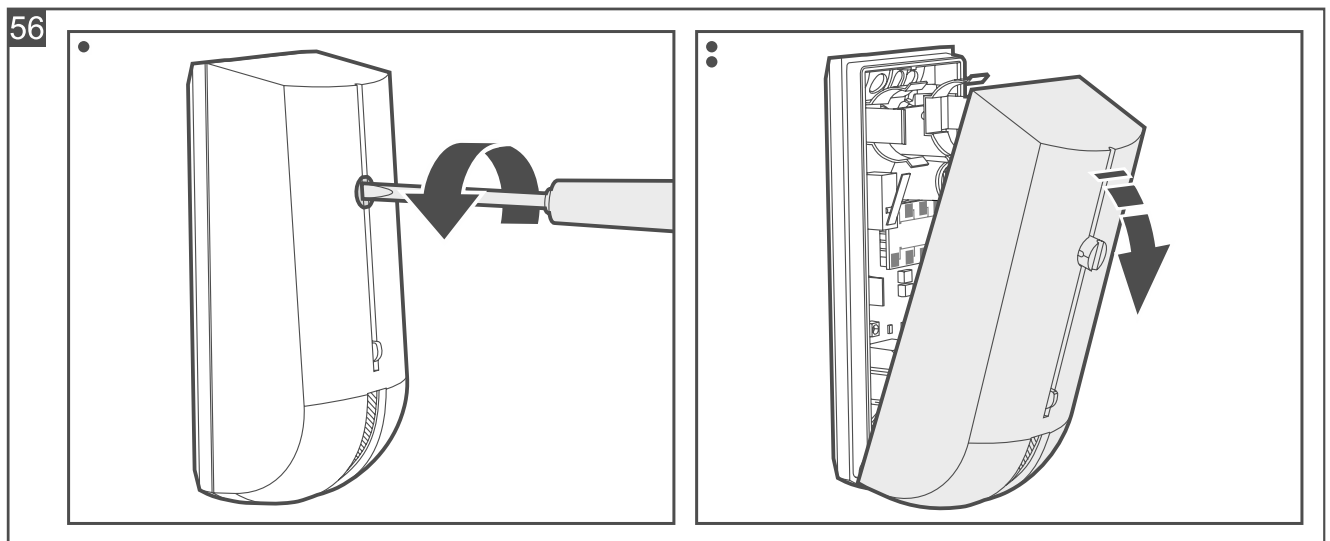

2. Push the fastening catches outward and remove the electronics board (Fig. 57).

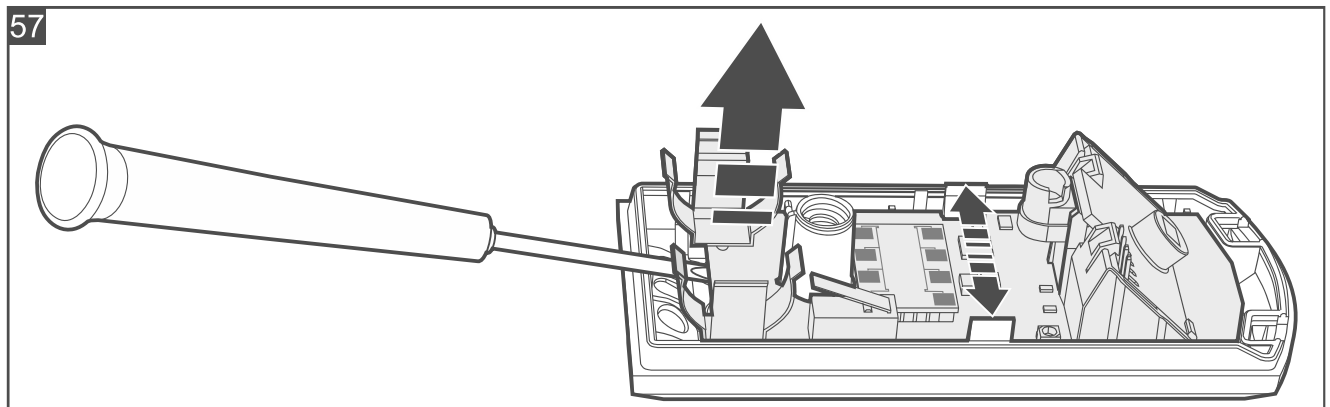

3. Secure the enclosure base to the wall (Fig. 58) or to the bracket mounted on the wall (Fig. 59). The wall plugs provided with the detector are intended for concrete or brick. For other types of surface (drywall, styrofoam), use other appropriately selected wall plugs.

**i** If the detector is to detect removal from the surface, secure the detector to the wall (do not use a bracket). In order for the detector to detect removal from the surface, fasten the screws in places marked with the **T** symbol in the figure.

The detector must detect removal from the surface if it is to meet the requirements of Standard EN 50131 for Grade 2.

To secure the tamper protection element (opening marked with the **T** symbol in the figure), use a smaller screw.

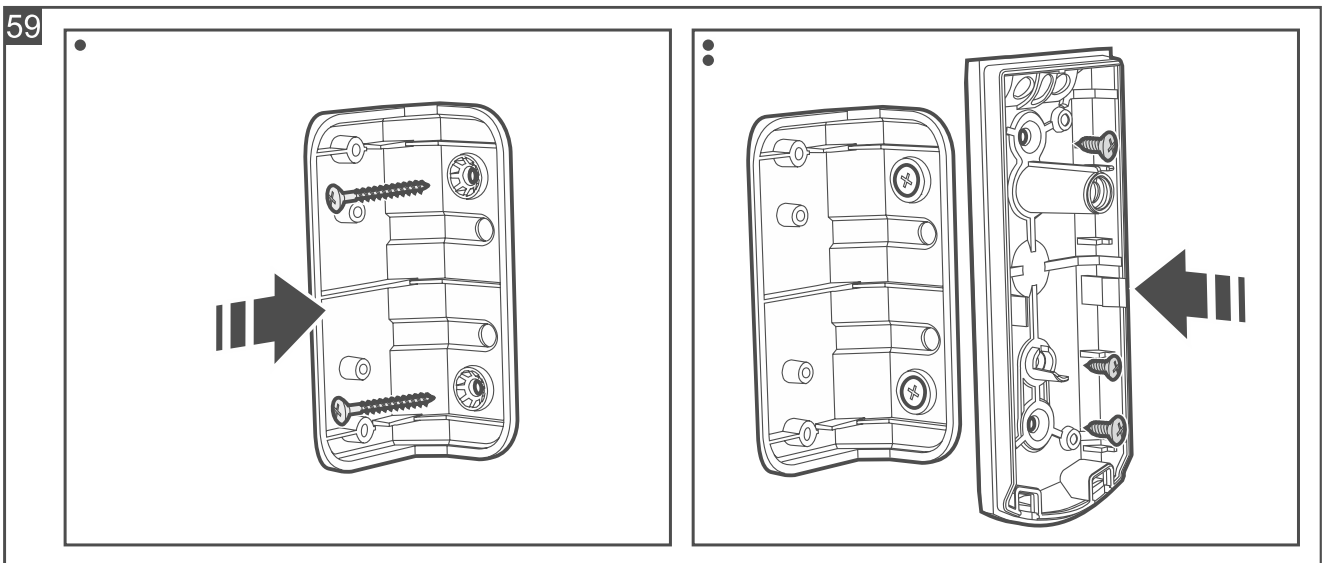
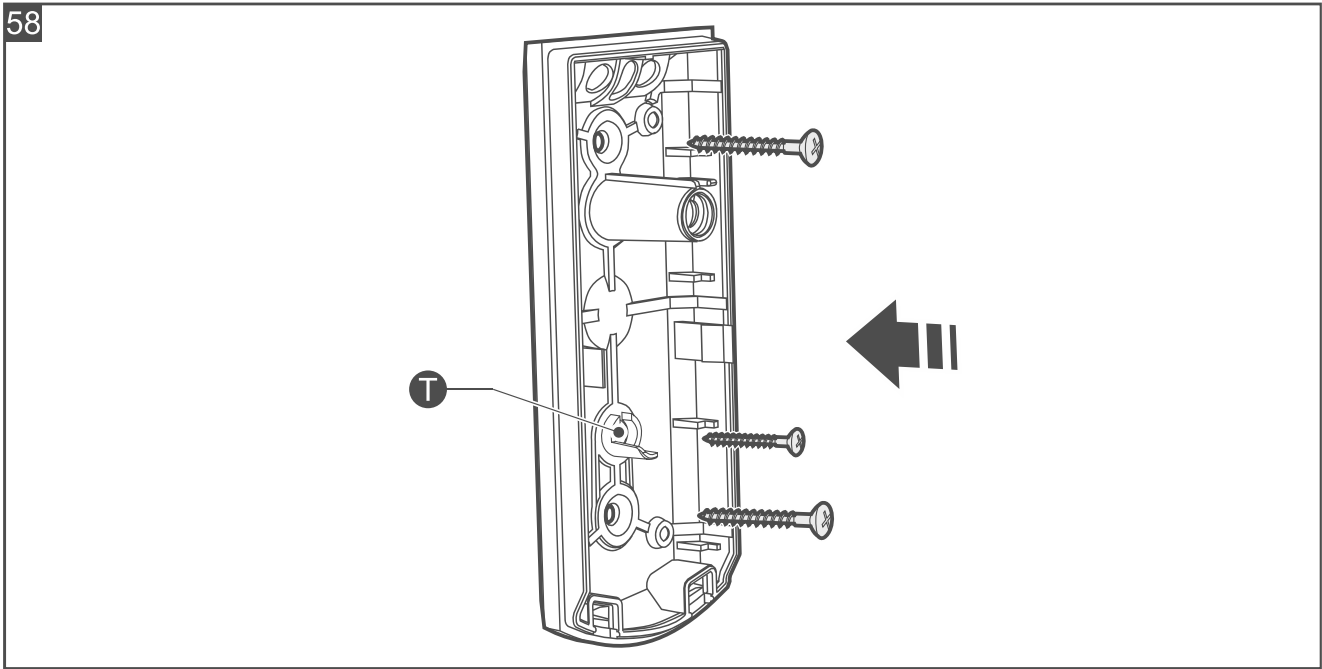

- 4. Fasten the electronics board in the enclosure.
- 5. Start the Be Wave app and add the detector to the system. When a request to turn on the device will be displayed, install the battery in the detector.
- 6. Close the enclosure.

## 4.5.7 Installing the Glass Break Detector

### Installation tips for the Glass Break Detector

- The detector should be installed indoors, in spaces with normal air humidity.
- Do not install the detector outdoors.
- Direct the detector microphone towards the protected glass pane – the best place to mount the detector is the wall opposite the protected glass pane.
- The distance between the detector and the protected glass pane must not exceed the detection range (6 m).
- The detection range depends on the room acoustics. Shades, curtains, furniture upholstery, acoustic tiles, etc. reduce the detection range.
- Do not install the detector on the same wall as the protected glass pane.
- Do not install the detector in the vicinity of sound emitting devices (loudspeaker, bell, air conditioner, etc.).

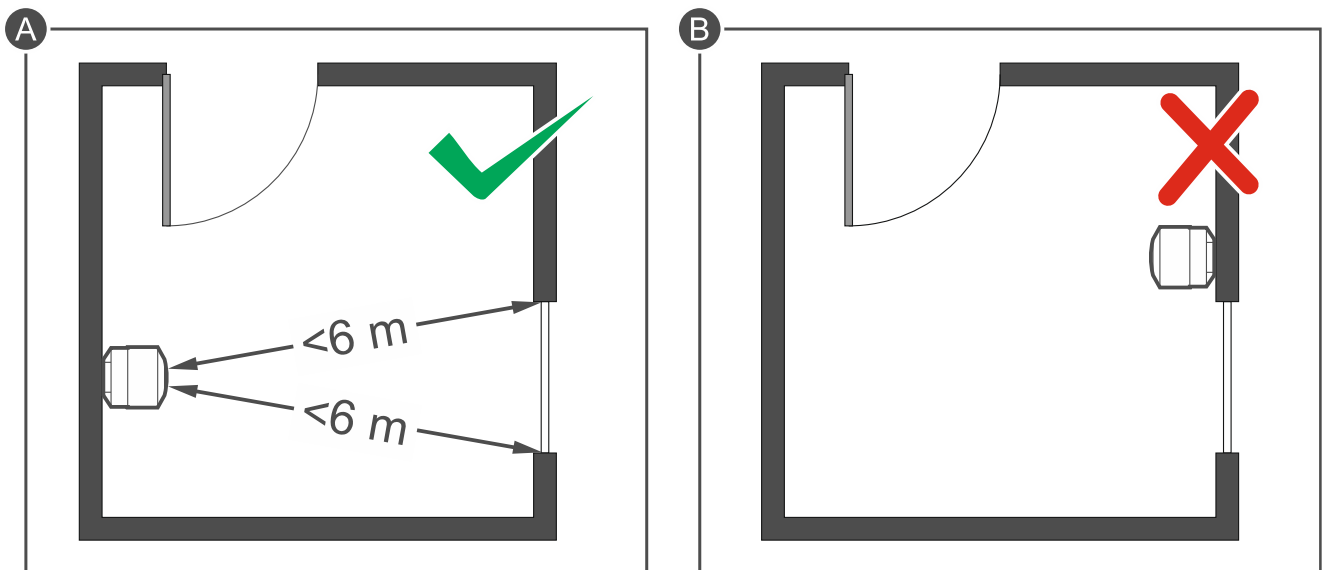

### Mounting the Glass Break Detector



*The figures show the detector installed vertically, but it may be mounted in any position (it has no effect on its operation).*

1. Open the detector enclosure (Fig. 60). The enclosure opening tool, shown in the figure, is provided with the detector.

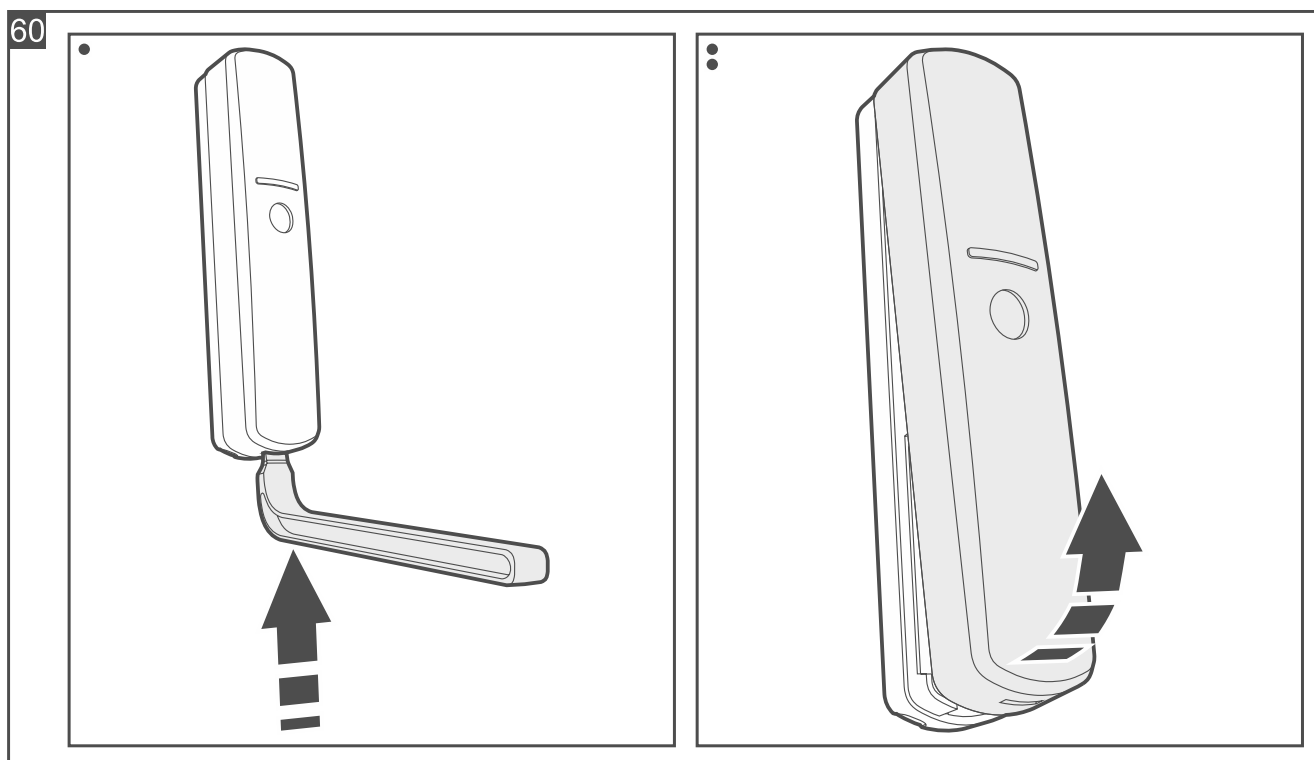

2. If the detector is to be mounted on the surface using a double-sided mounting tape (Fig. 61):
  - stick the tape to the enclosure base.
  - stick the enclosure base to the surface.

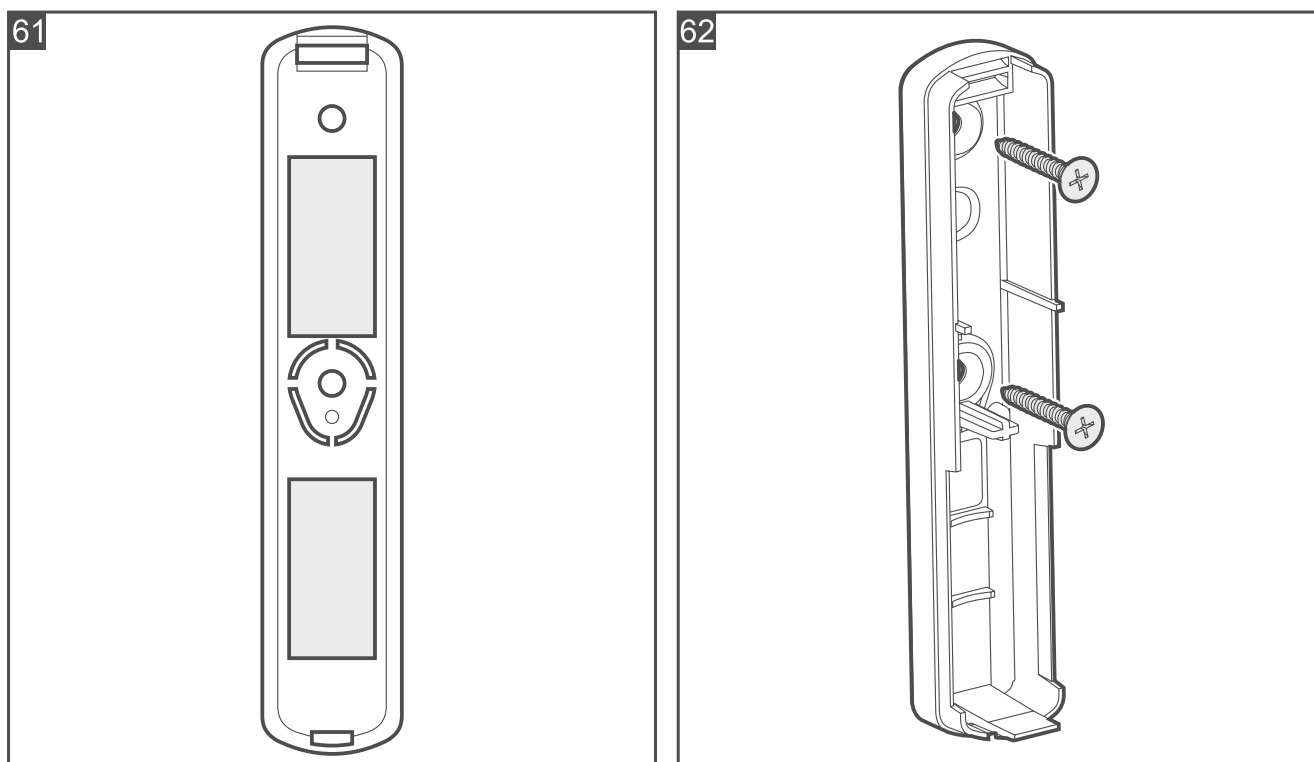

3. If the detector is to be mounted on the surface with screws:
  - place the enclosure base against the surface and mark the location of the mounting holes.

- drill the holes in the surface for wall plugs (anchors). The wall plugs provided with the detector are intended for concrete or brick. For other types of surface (drywall, styrofoam), use other appropriately selected wall plugs.
- secure the enclosure base to the surface with screws (Fig. 62).



*If the detector is to detect removal from the surface, secure the detector with screws.*

*The detector must detect removal from the surface if it is to meet the requirements of Standard EN 50131 for Grade 2.*

4. Start the Be Wave app and add the detector to the system. When a request to turn on the device will be displayed, install the battery in the detector.
5. Close the enclosure.

#### 4.5.8 Installing the Multipurpose Detector



*Remember the detector may be used for different purposes and it affects the way it should be installed.*

#### Description of the Multipurpose Detector

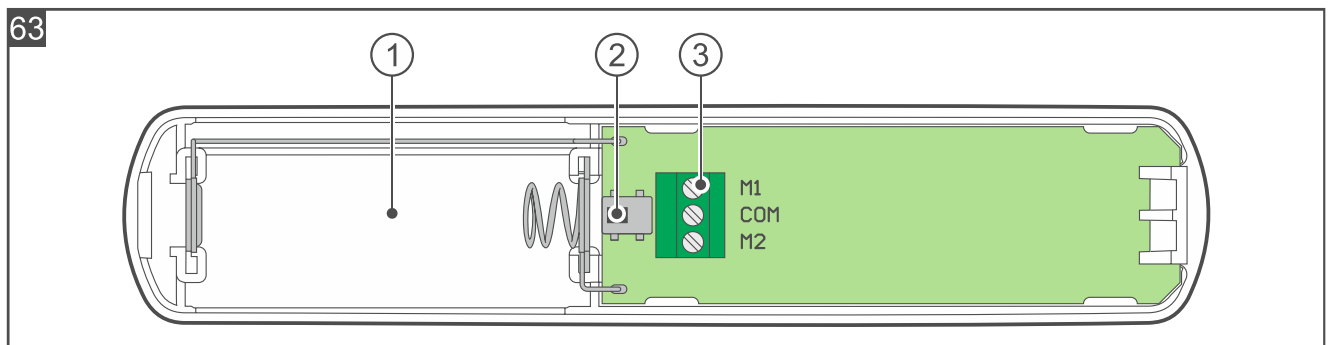

The figure shows the inside of the detector after opening the enclosure.

① battery holder (CR123A 3 V).

② tamper switch.

③ terminals:

**M1** - terminal for connecting a wired NC detector (*Opening detector / Shock and opening detector / Roller shutter detector*) or the FPX-1 flood probe (*Flood detector*).

**COM** - common ground.

**M2** - terminal for:

- disabling the built-in opening sensor (*Opening detector / Shock and opening detector*). If you want to disable the built-in opening sensor, connect the M2 terminal to the COM terminal.
- connecting a roller shutter detector (*Roller shutter detector*).



*By default, the M1 and COM terminals are shorted with a wire. Do not remove the wire if you are not planning to connect a wired detector or the flood probe to the terminals.*

#### Installation tips for the Multipurpose Detector

- The detector should be installed indoors, in spaces with normal air humidity.
- Do not install the detector outdoors.

### **Opening detector / Shock and opening detector / Roller shutter detector**

- Install the detector on the window / door frame (fixed surface). Install the detector in the upper part of the window frame. This will reduce the risk of flooding the detector when the window is tilted or open.
- Install the magnet on the window / door (moving surface).
- Do not install the detector on ferromagnetic surfaces or in the vicinity of strong magnetic or electric fields.
- To connect a wired NC detector / roller shutter detector, use wires with a cross-section of 0.5-0.75 mm<sup>2</sup>. The length of the wires should not exceed 3 m.

### **Mounting the Multipurpose Detector**

**i** | The figures show the detector mounted vertically, but it may be mounted in any position (it has no effect on its operation).

1. Open the detector enclosure (Fig. 64). The enclosure opening tool, shown in the figure, is provided with the detector.

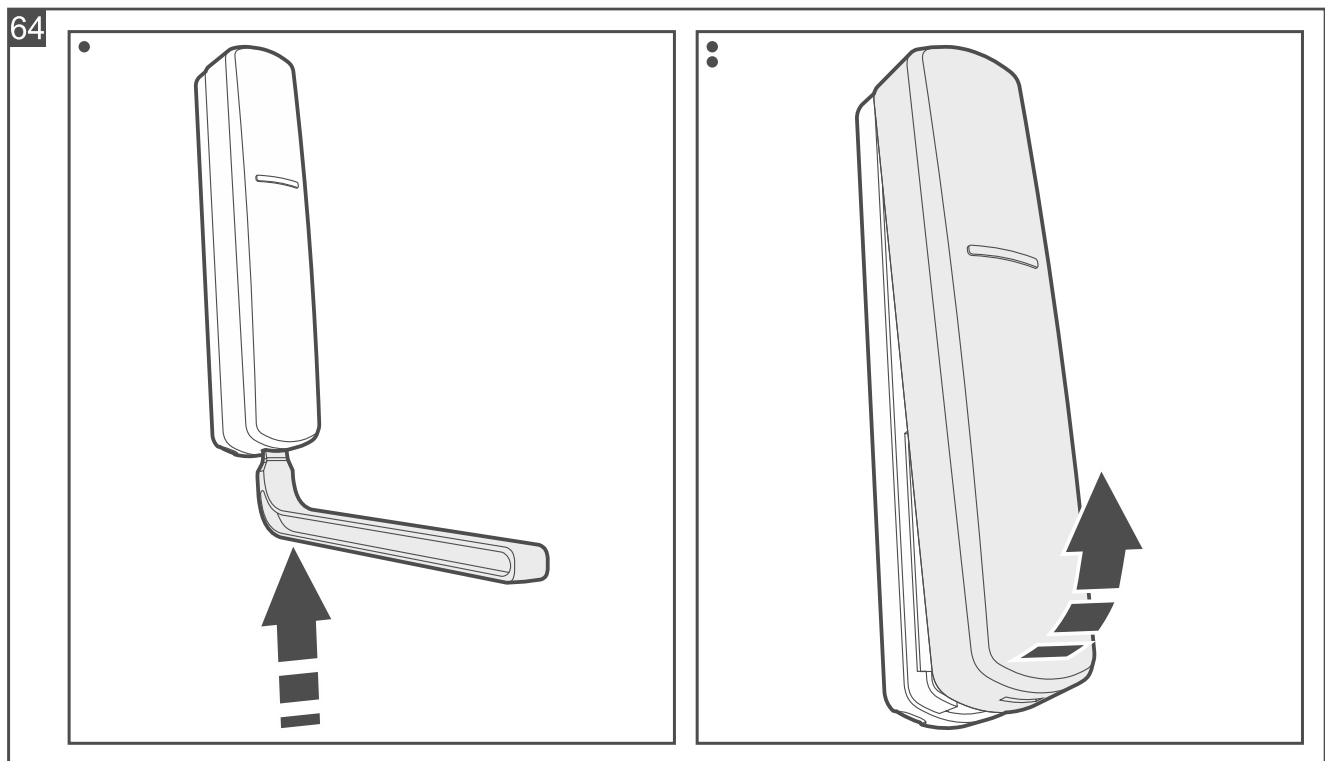

2. **Opening detector / Shock and opening detector / Roller shutter detector.** If you want to connect a wired NC detector or a roller shutter detector:
  - make the opening for a cable in the enclosure base.
  - run the detector cable through the opening.
3. **Flood detector:**
  - make the opening for a cable in the enclosure base.
  - run the FPX-1 flood probe cable through the opening.

**i** | The FPX-1 flood probe is sold separately.

4. If the detector is to be mounted on the surface using a double-sided mounting tape (Fig. 65):
  - stick the tape to the enclosure base.
  - stick the enclosure base to the surface.

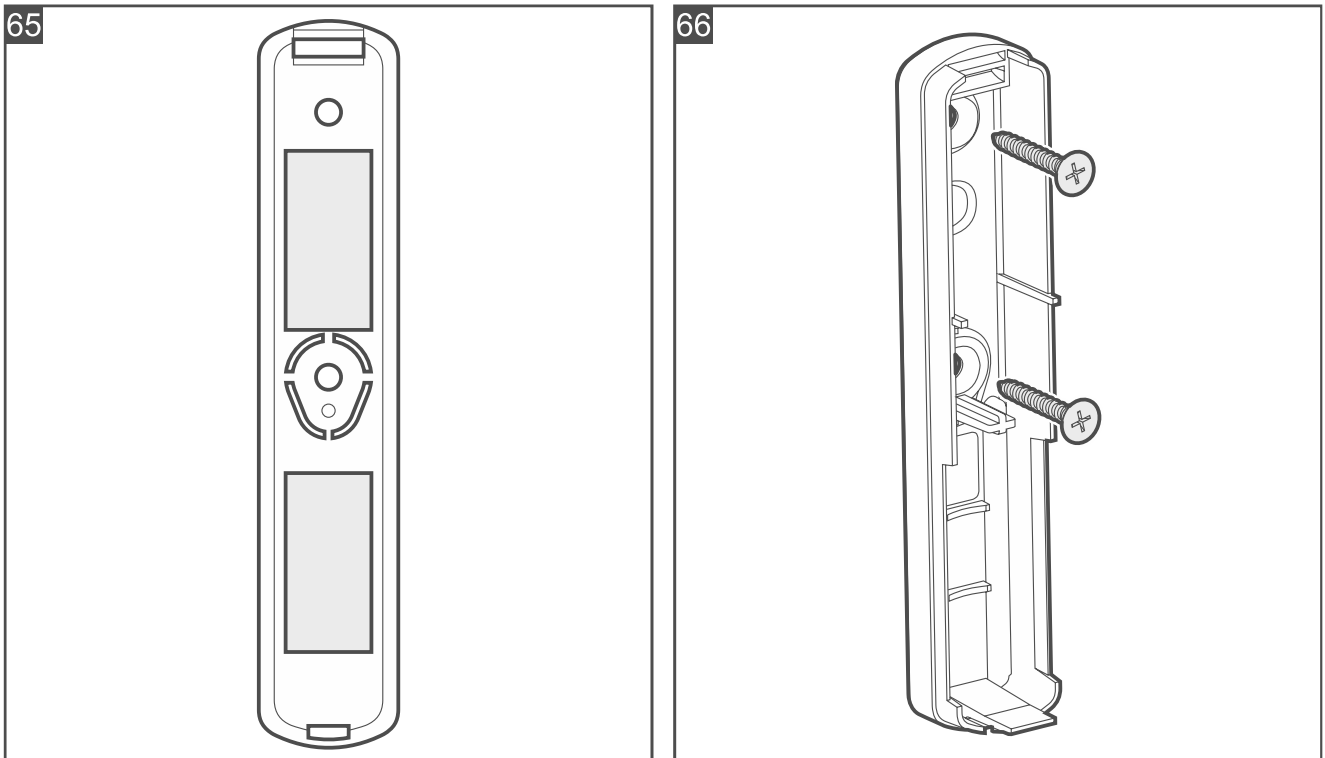

5. If the detector is to be mounted on the surface with screws:
- place the enclosure base against the surface and mark the location of the mounting holes.
  - drill the holes in the surface for wall plugs (anchors). The wall plugs provided with the detector are intended for concrete or brick. For other types of surface (drywall, styrofoam), use other appropriately selected wall plugs.
  - secure the enclosure base to the surface with screws (Fig. 66).



*If the detector is to detect removal from the surface, secure the detector with screws.*

*The detector must detect removal from the surface if it is to meet the requirements of Standard EN 50131 for Grade 2.*

*If the detector is to operate as the Shock detector or Shock and opening detector, it is recommended to secure it to the surface with screws.*

6. **Opening detector / Shock and opening detector / Roller shutter detector.** Install the magnet as shown in Fig. 67. You can secure the surface magnet using a double-sided mounting tape or screws. You can use several spacers (Fig. 68). To make a hole for the flush magnet, use the  $\varnothing 9$  mm drill bit.



*If you are planning to disable the built-in opening sensor, do not install the magnet (Shock and opening detector).*

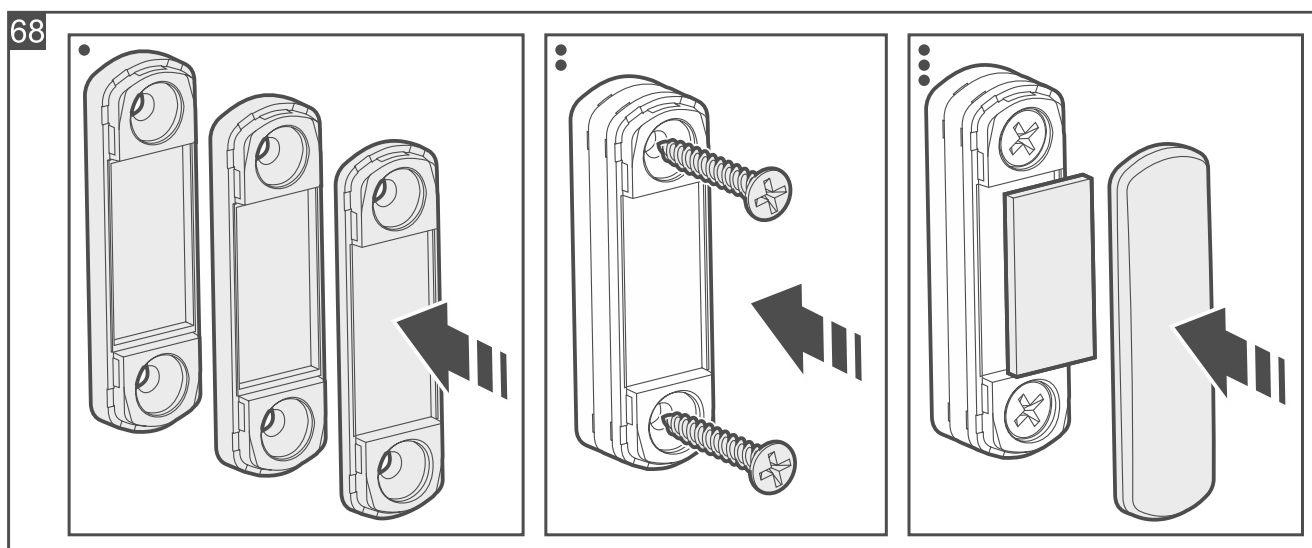
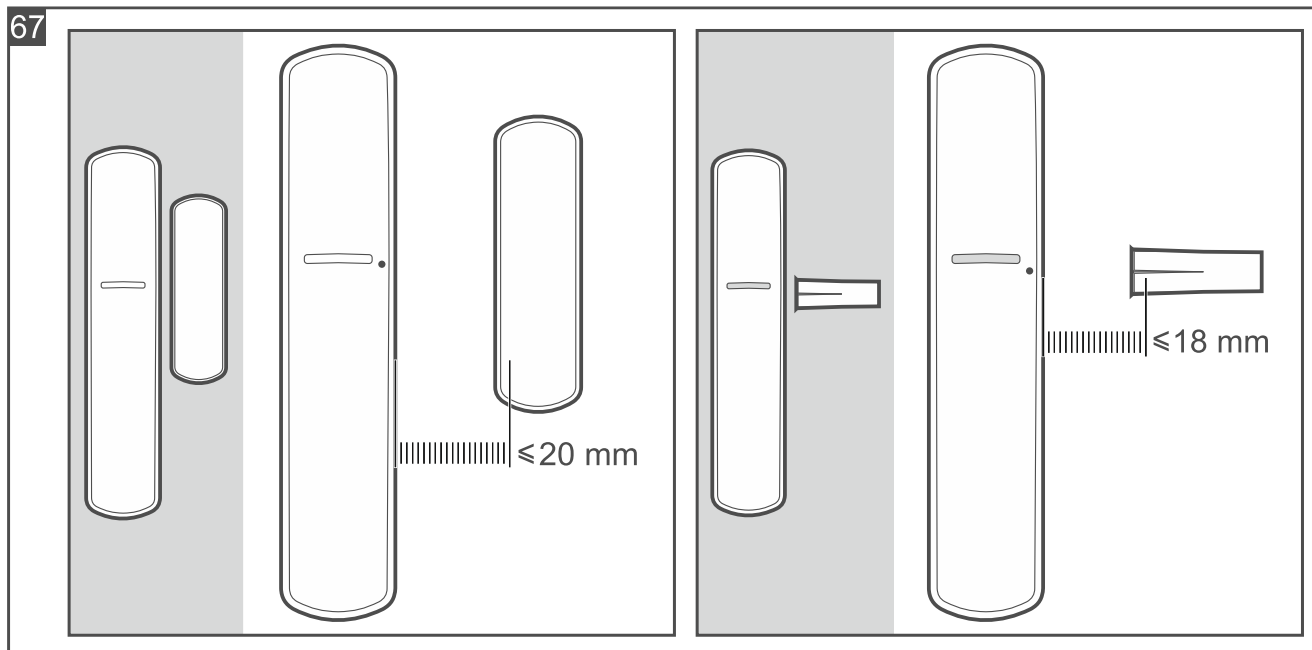

### 7. **Opening detector / Shock and opening detector:**

- if you are connecting a wired NC detector, screw the detector wires to the COM and M1 terminals on the electronics board.
- if you want to disable the built-in opening sensor, use a wire to connect the M2 and COM terminals.

### 8. **Flood detector:**

- secure the flood probe to the wall with screws (Fig. 69).
- screw the probe wires to the COM and M1 terminals on the electronics board.

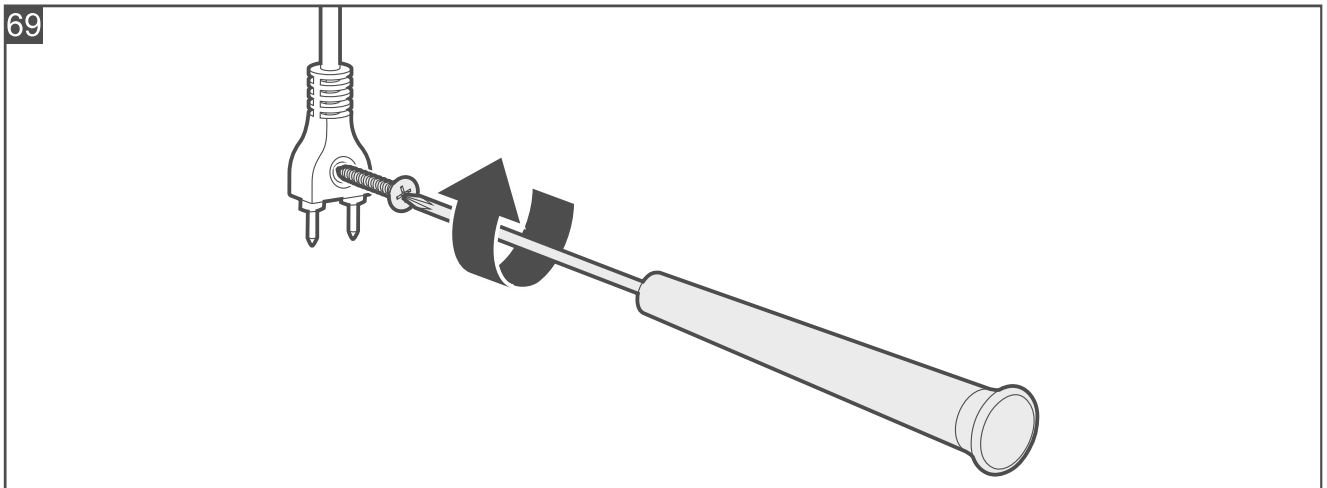

#### 9. **Roller shutter detector:**

- screw the roller shutter detector wires to the COM and M2 terminals on the electronics board.
  - if you are connecting a wired NC detector, screw the detector wires to the COM and M1 terminals on the electronics board.
10. Start the Be Wave app and add the detector to the system. When a request to turn on the device will be displayed, install the battery in the detector.
11. Close the enclosure.

### 4.5.9 Installing the Opening Detector

#### Description of the Opening Detector

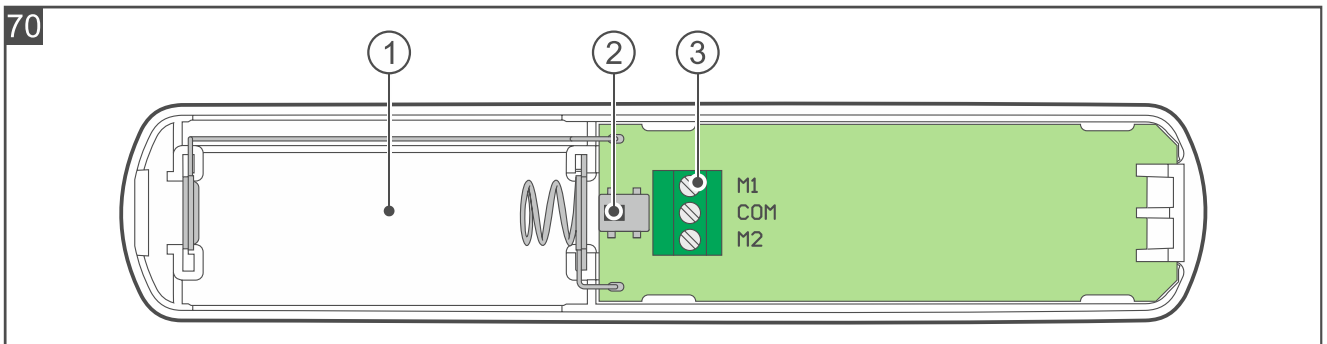

The figure shows the inside of the detector after opening the enclosure.

- ① battery holder (CR123A 3 V).
- ② tamper switch.
- ③ terminals:
  - M1** - terminal for connecting a wired NC detector.
  - COM** - common ground.
  - M2** - terminals for disabling the built-in opening sensor. If you want to disable the built-in opening sensor, connect the M2 terminal to the COM terminal.



*By default, the M1 and COM terminals are shorted with a wire. Do not remove the wire if you are not planning to connect a wired detector to the terminals.*

#### Installation tips for the Opening Detector

- The detector should be installed indoors, in spaces with normal air humidity.
- Do not install the detector outdoors.

- Install the detector on the window / door frame (fixed surface). Install the detector in the upper part of the window frame. This will reduce the risk of flooding the detector when the window is tilted or open.
- Install the magnet on the window / door (moving surface).
- Do not install the detector on ferromagnetic surfaces or in the vicinity of strong magnetic or electric fields.
- To connect a wired NC detector, use wires with a cross-section of 0.5-0.75 mm<sup>2</sup>. The length of the wires should not exceed 3 m.

## Mounting the Opening Detector



*The figures show the detector installed vertically, but the detector may be installed in any position (it has no effect on its operation).*

1. Open the detector enclosure (Fig. 71). The enclosure opening tool, shown in the figure, is provided with the detector.

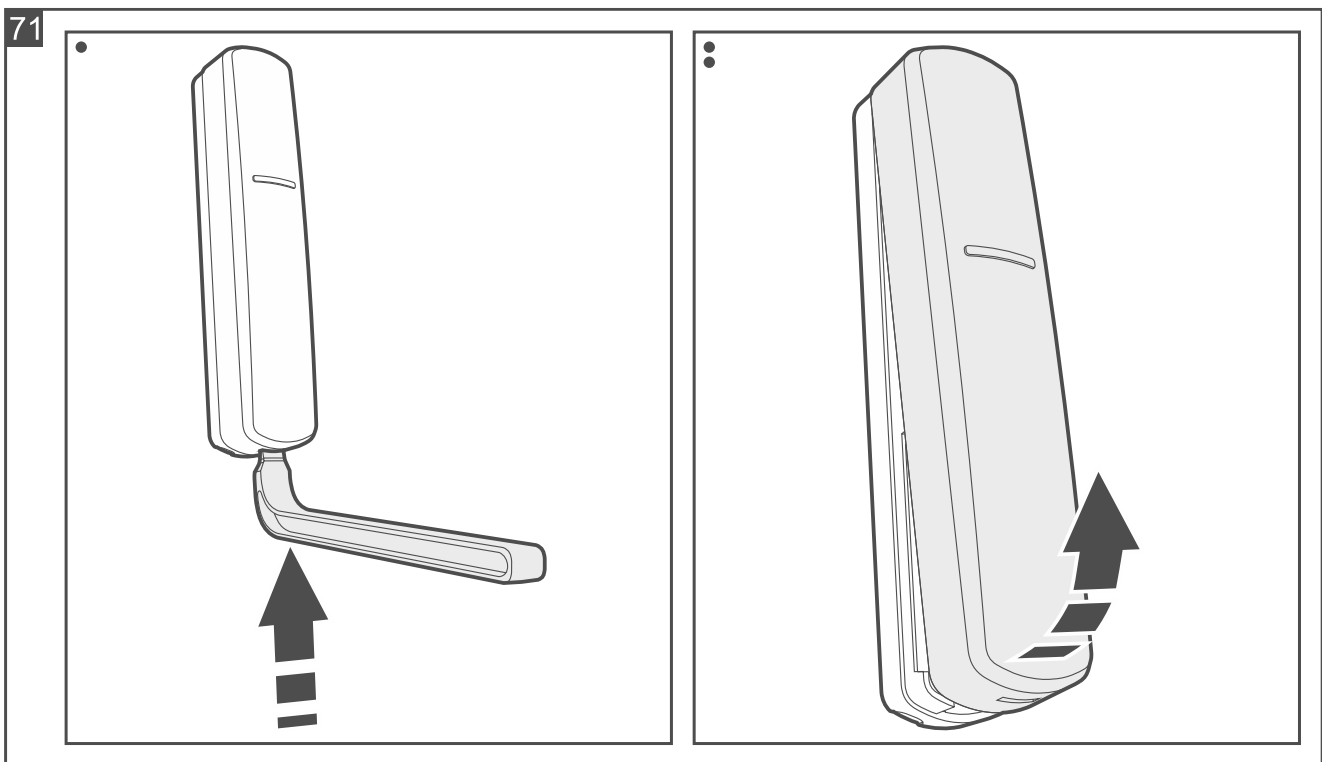

2. If you want to connect a wired NC detector:
  - make the opening for a cable in the enclosure base.
  - run the detector cable through the opening.
3. If the detector is to be mounted on the surface using a double-sided mounting tape (Fig. 72):
  - stick the tape to the enclosure base.
  - stick the enclosure base to the surface.
4. If the detector is to be mounted on the surface with screws:
  - place the enclosure base against the surface and mark the location of the mounting holes.
  - drill the holes in the surface for wall plugs (anchors). The wall plugs provided with the detector are intended for concrete or brick. For other types of surface (drywall, styrofoam), use other appropriately selected wall plugs.
  - secure the enclosure base to the surface with screws (Fig. 73).



*If the detector is to detect removal from the surface, secure the detector with screws.*

*The detector must detect removal from the surface if it is to meet the requirements of Standard EN 50131 for Grade 2.*

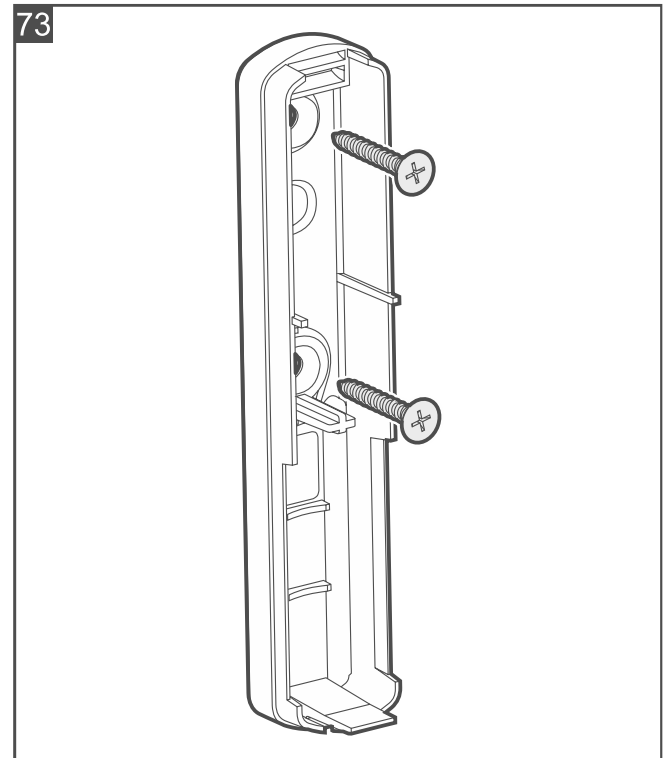
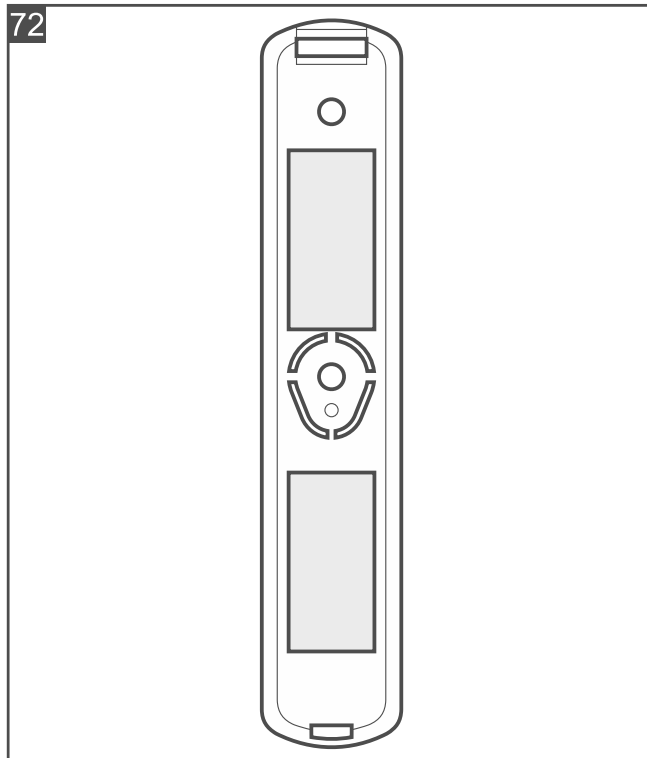

5. Install the magnet as shown in Fig. 74. You can secure the surface magnet using a double-sided mounting tape or screws. You can use several spacers (Fig. 75). To make a hole for the flush magnet, use the  $\varnothing 9$  mm drill bit.



*If you are planning to disable the built-in opening sensor, do not install the magnet.*

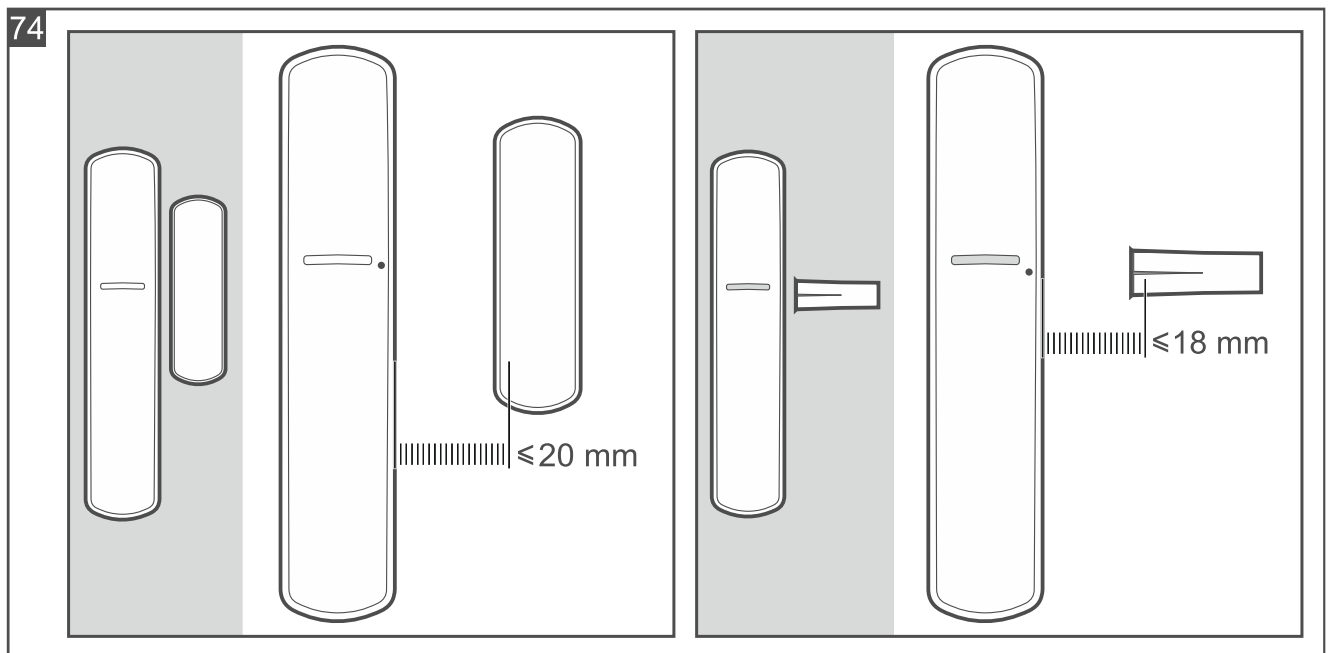

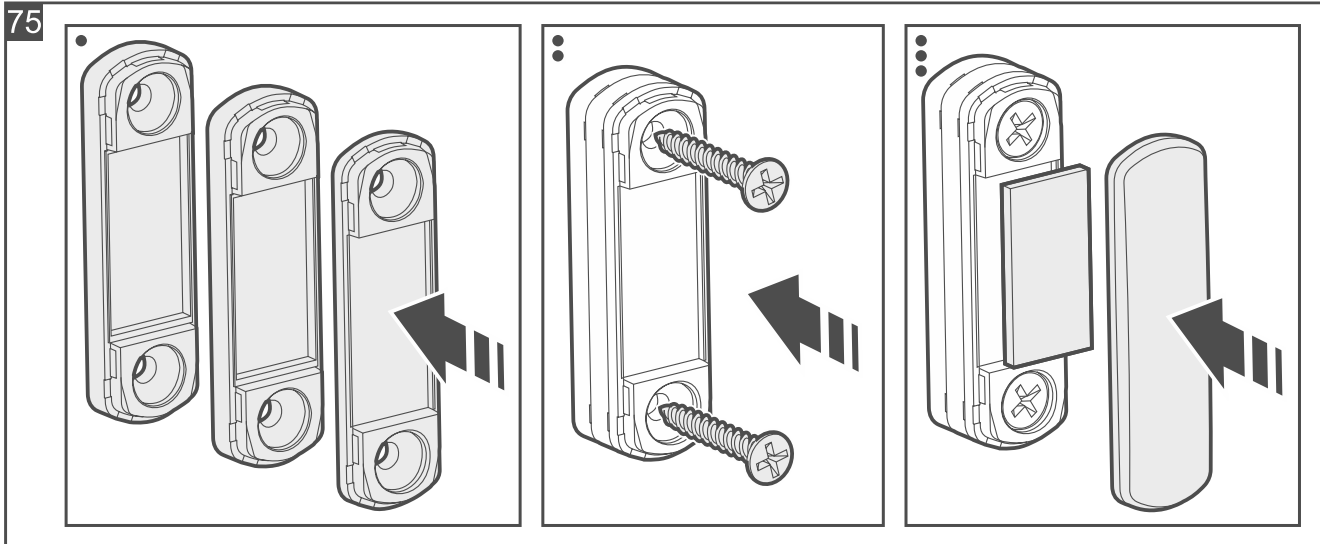

6. If you are connecting a wired NC detector, screw the detector wires to the COM and M1 terminals on the electronics board.
7. If you want to disable the built-in opening sensor, use a wire to connect the M2 and COM terminals.
8. Start the Be Wave app and add the detector to the system. When a request to turn on the device will be displayed, install the battery in the detector.
9. Close the enclosure.

#### 4.5.10 Installing the Flood Detector

##### Installation tips for the Flood Detector

- The detector should be used indoors, in spaces with normal air humidity.
- Do not use the detector outdoors.
- Place the detector on the floor in an area prone to flooding.

##### Start-up the Flood Detector

1. Open the detector enclosure (Fig. 76).

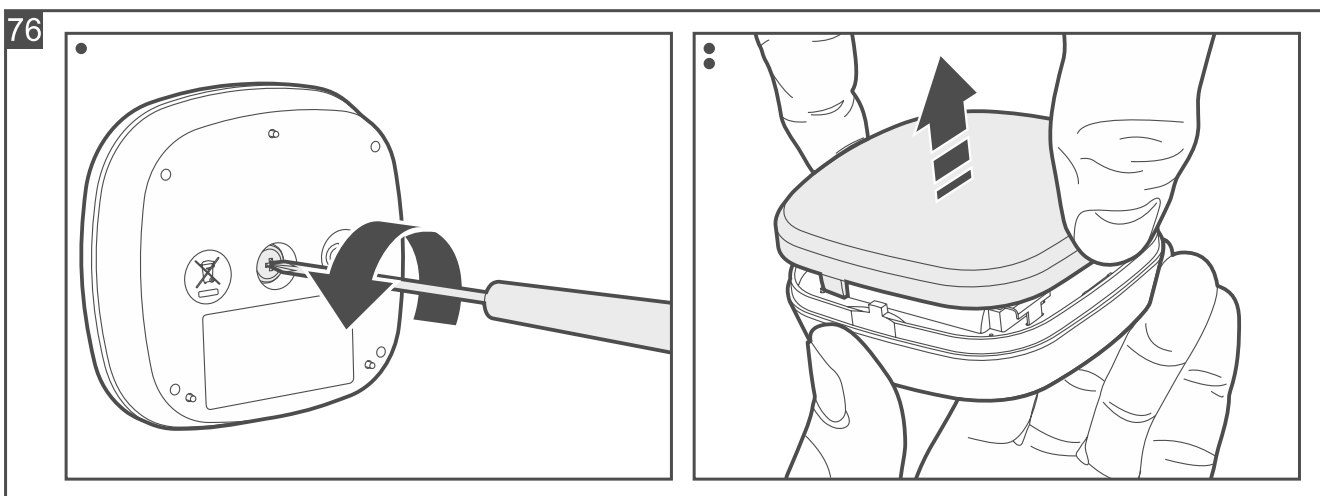

2. Start the Be Wave app and add the detector to the system. When a request to turn on the device will be displayed, install the battery in the detector.

3. Close the detector enclosure (note that the cover only fits in one position) and secure it with a screw (Fig. 77).

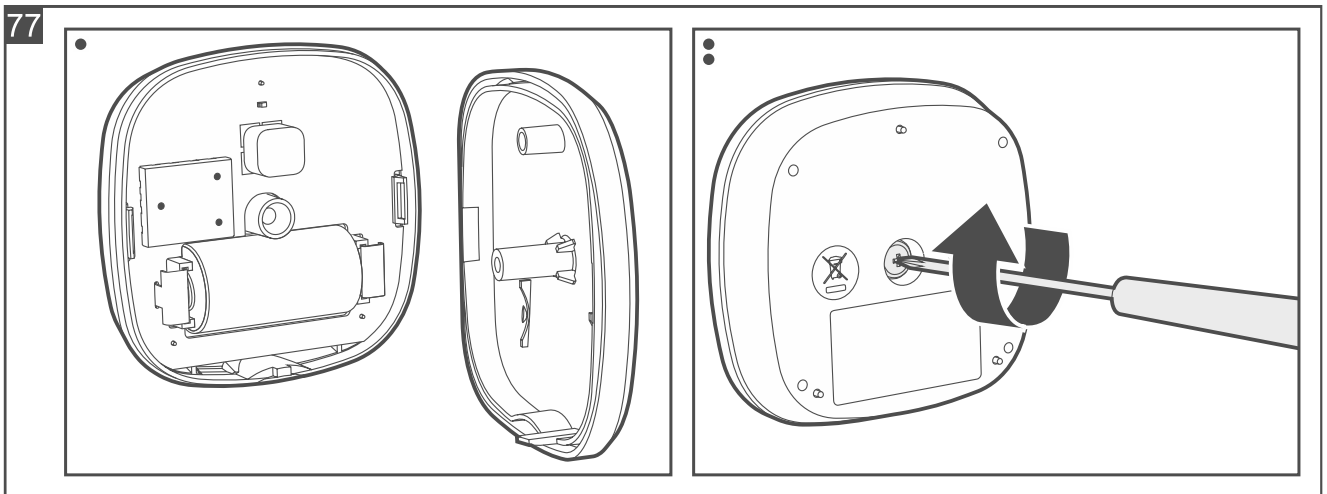

4. Place the detector on the floor in the selected area.

### 4.5.11 Installing the Fire Detector Plus / Fire Detector Pro

#### Installation tips for the Fire Detector Plus / Fire Detector Pro

- The detector should be installed indoors, in spaces with normal air humidity.
- Do not install the detector outdoors.
- The detector should be installed on the ceiling, as close as possible to the center of the room.
- Do not install the detector in places with high concentration of dust and/or formation and condensation of water steam.
- Do not install the detector near heaters, cookers, fans or air-conditioner outlets.
- Do not install the detector in places where there is no unobstructed movement of air (e.g. in recesses, niches, etc.).

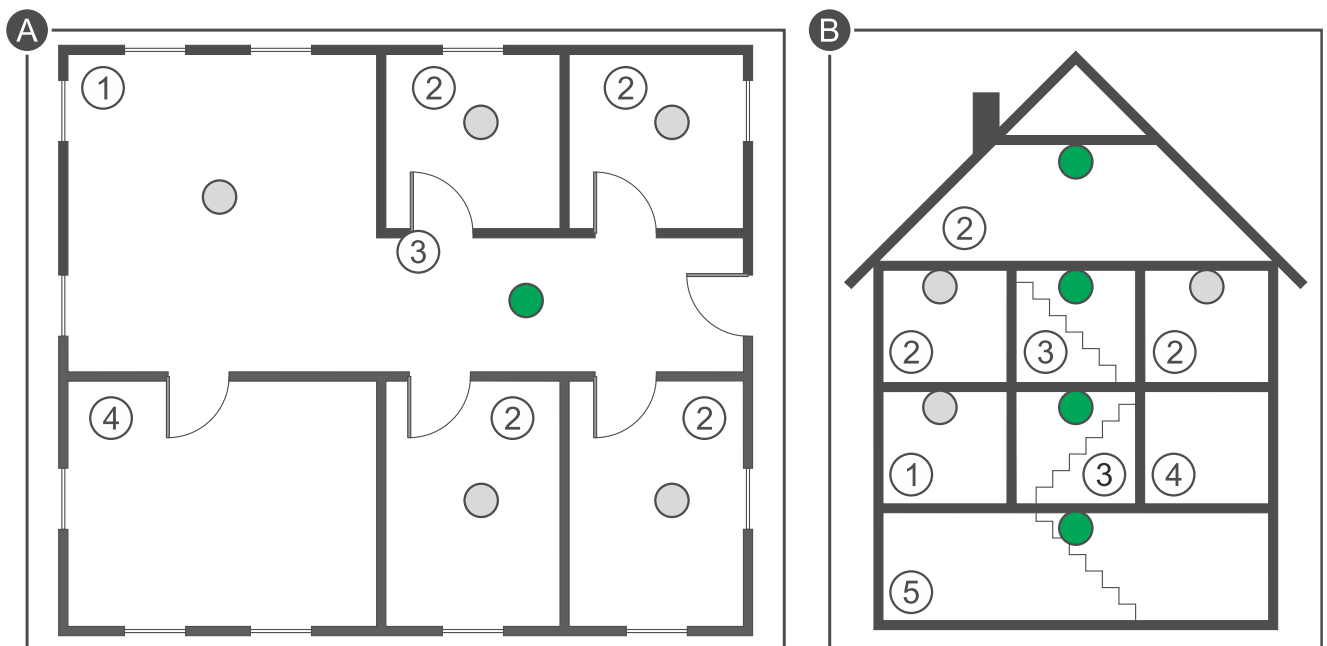

Explanations for figures A and B:

- ① living room.

- ② bedroom.
- ③ hall, lobby, etc.
- ④ kitchen.
- ⑤ basement.
- primary location for detector installation.
- additional location for detector installation.

### Mounting the Fire Detector Plus / Fire Detector Pro

**i** The figures show the Fire Detector Plus.

*Do not remove the jumper from the pins on the Fire Detector Pro electronics board.*

1. Remove the plastic dust cup.
2. Turn the cover counter-clockwise (Fig. 78) and remove it (Fig. 79).

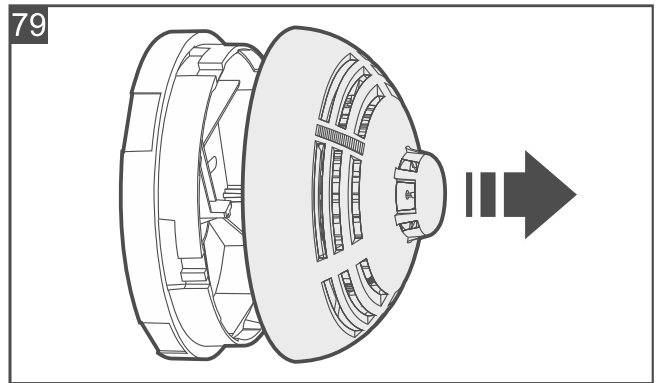
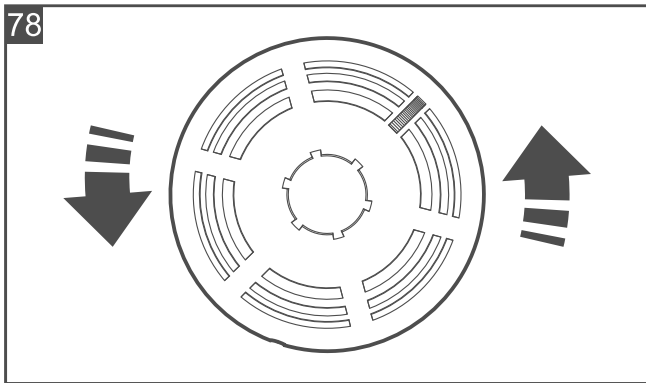

3. If the detector is to be mounted on the ceiling using a double-sided mounting tape (Fig. 80):
  - stick the tape to the enclosure base.
  - stick the enclosure base to the ceiling.

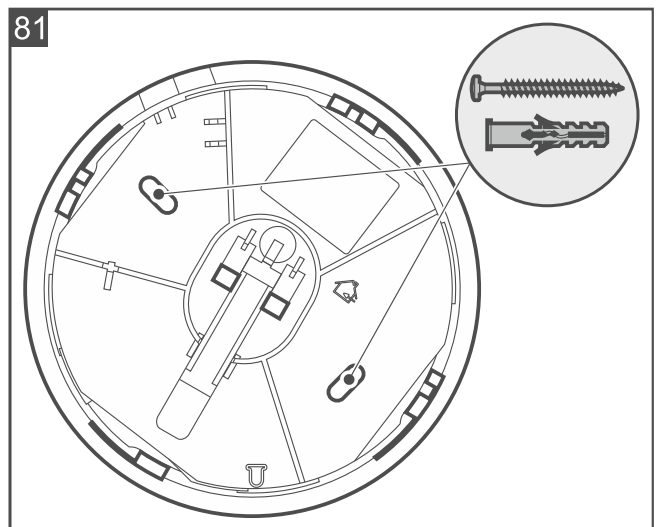
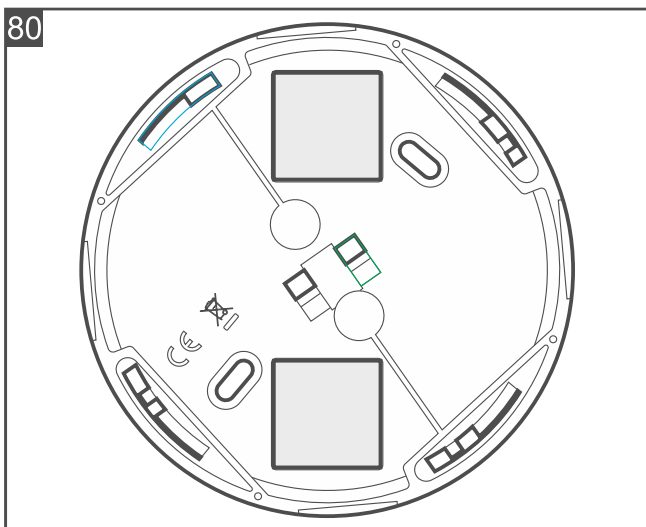

4. If the detector is to be mounted on the ceiling with screws:
  - place the enclosure base against the ceiling and mark the location of the mounting holes (Fig. 81).

- drill the holes in the ceiling for wall plugs (anchors). The wall plugs provided with the detector are intended for concrete or brick. For other types of surface (drywall, styrofoam), use other appropriately selected wall plugs.
  - secure the enclosure base to the ceiling with screws.
5. Start the Be Wave app and add the detector to the system. When a request to turn on the device will be displayed, install the battery in the detector.
  6. Replace the detector cover and lock it with a screw. The screw is provided in a bag together with the wall plugs and screws for mounting.



*The cover cannot be replaced when there is no battery inside the detector.*

7. Press the test / reset button (Fig. 82). A fire alarm should be generated soon after. The alarm will be signaled by the detector (continuous sound, LED indicator ON). You will receive a notification from the Be Wave app.

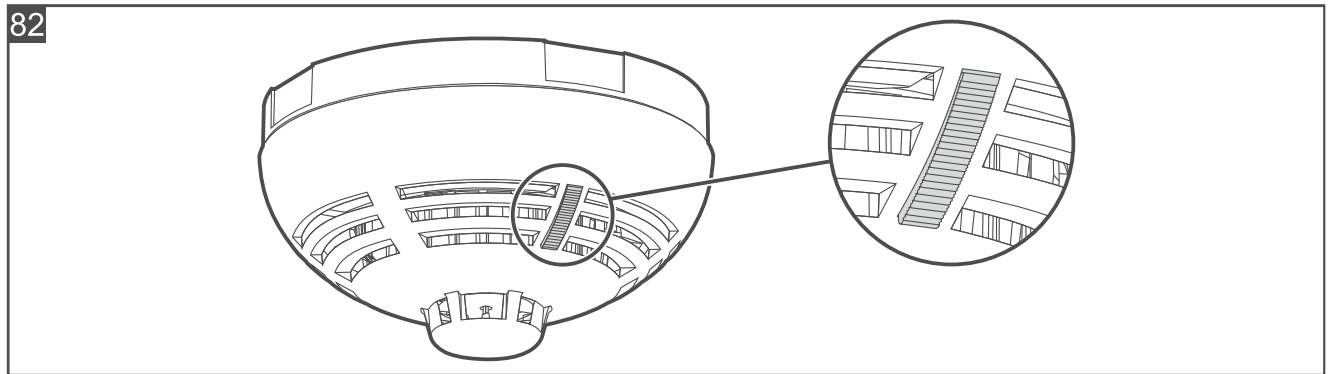

8. Press again the test / reset button to clear the alarm.



*If in the premises where the detector is installed, any work is being carried out that may cause dirt to build up in the smoke chamber, put a plastic dust cover on the detector. Remove it after the work is finished.*

#### 4.5.12 Installing the Carbon Monoxide Detector

##### Installation tips for the Carbon Monoxide Detector

- The detector should be installed indoors, in spaces with normal air humidity.
- Do not install the detector outdoors.
- Recommended place of installation:
  - bedroom,
  - room with a fireplace / combustion equipment, where there is a risk that carbon monoxide is produced.
- Install the detector at a height of about 1.5-2 meters from the ground.
- Do not install the detector in places where lacquers, glues, paint removers or aerosols are used. It may cause damage to the gas sensor.

##### Mounting the Carbon Monoxide Detector



*Do not remove the jumper from the pins on the electronics board.*

1. Turn the cover counter-clockwise (Fig. 83) and remove it (Fig. 84).

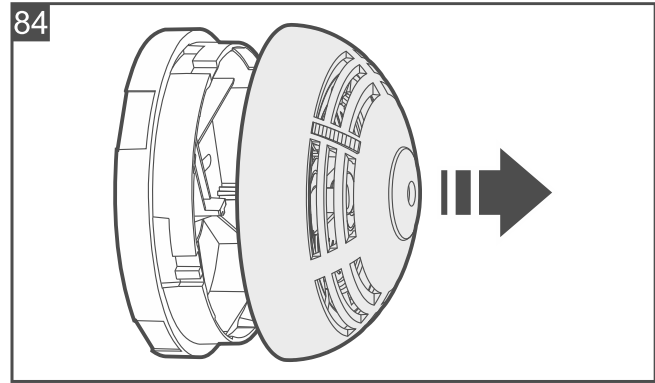
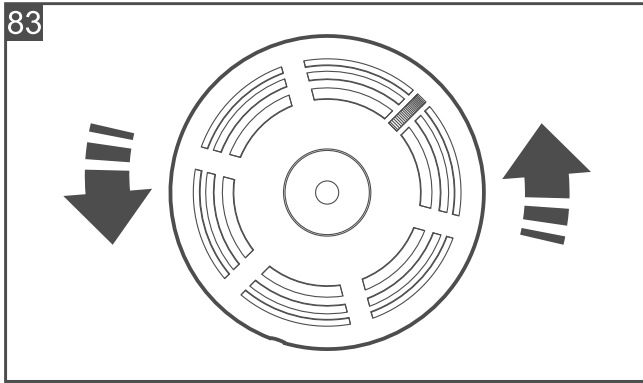

2. If the detector is to be mounted on the wall using a double-sided mounting tape (Fig. 85):
  - stick the tape to the enclosure base.
  - stick the enclosure base to the wall.

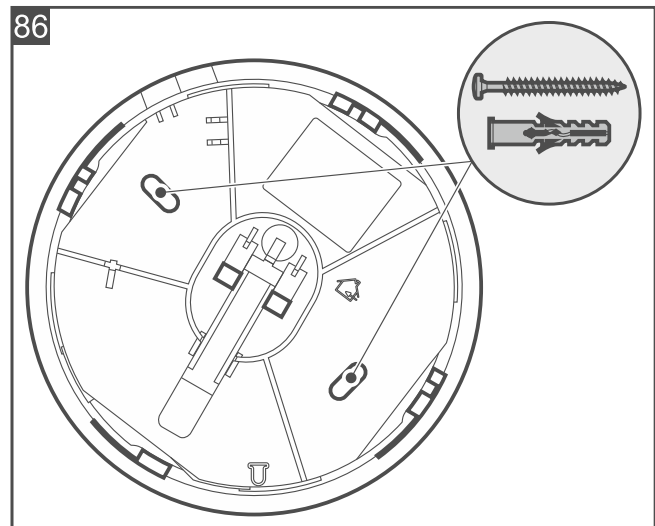
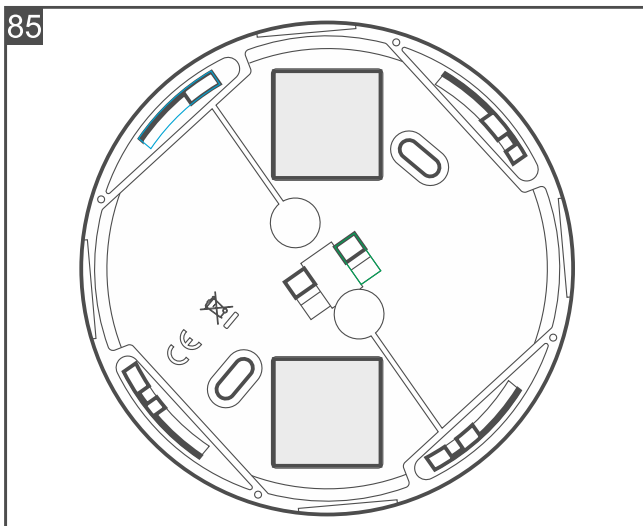

3. If the detector is to be mounted on the wall with screws:
  - place the enclosure base against the wall and mark the location of mounting holes (Fig. 86).
  - drill the holes in the wall for wall plugs (anchors). The wall plugs provided with the detector are intended for concrete or brick. For other types of surface (drywall, styrofoam), use other appropriately selected wall plugs.
  - secure the enclosure base to the wall with screws.
4. Start the Be Wave app and add the detector to the system. When a request to turn on the device will be displayed, install the battery in the detector.
5. Replace the detector cover and lock it with a screw. The screw is provided in a bag together with the wall plugs and screws for mounting.



*The cover cannot be replaced when there is no battery inside the detector.*

- Press the test / reset button (Fig. 87). An alarm should be generated soon after. The alarm will be signaled by the detector (continuous sound, LED indicator ON). You will receive a notification from the Be Wave app.

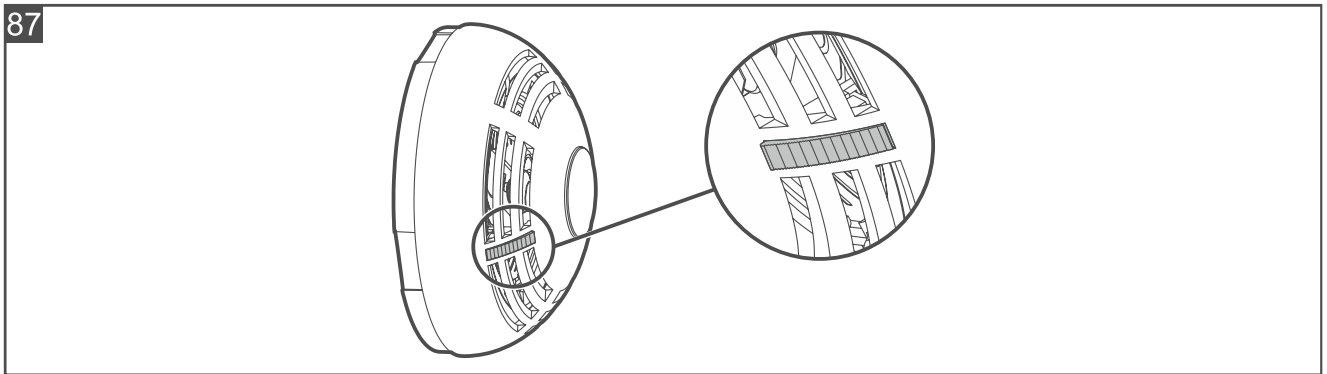

- Press again the test / reset button to clear the alarm.

### 4.5.13 Installing the Outdoor Dusk Detector

#### Installation tips for the Outdoor Dusk Detector

- Do not install the detector in places where it will be exposed to direct sunlight. Excessive temperature may e.g. cause damage to the dusk sensor or battery.

#### Mounting the Outdoor Dusk Detector



*The figures show the detector mounted vertically, but it may be mounted in any position (it has no effect on its operation).*

- Press the gasket into the groove of the enclosure cover. The gasket must fill the entire groove. Both ends of the gasket should meet (Fig. 88). The gasket is longer than the groove. Cut the excess gasket when you have filled the entire groove.

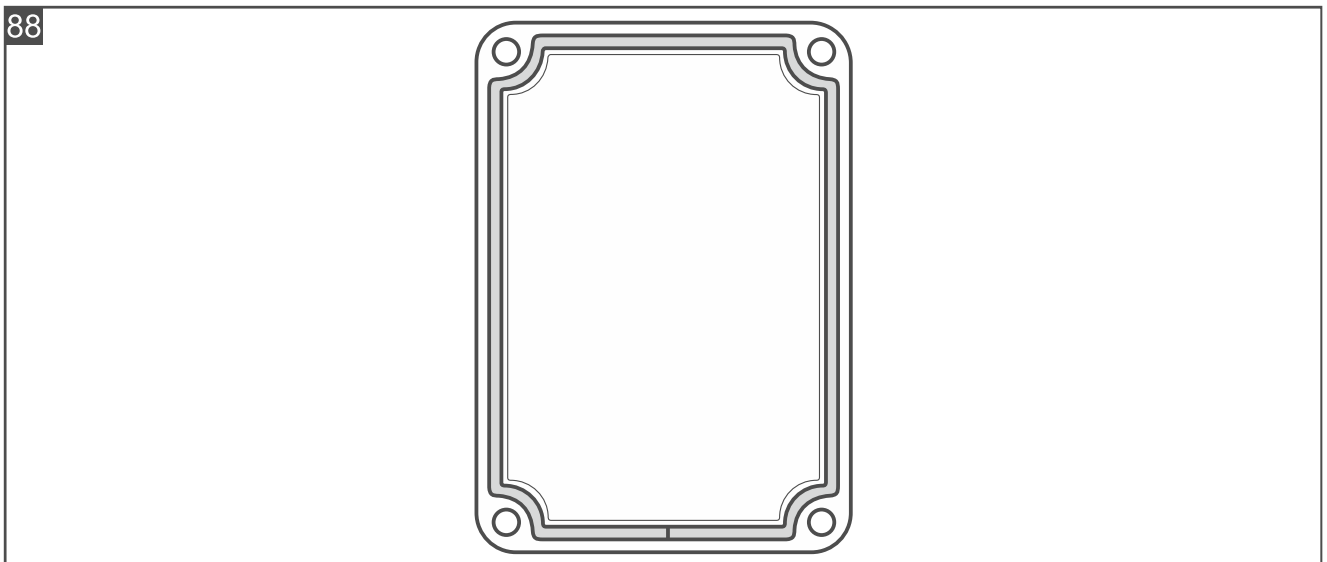

- Start the Be Wave app and add the detector to the system. When a request to turn on the device will be displayed, install the battery in the detector.
- Replace the cover and secure it to the enclosure base with screws (Fig. 89).



*When replacing the cover, make sure the gasket ends are on the bottom.*

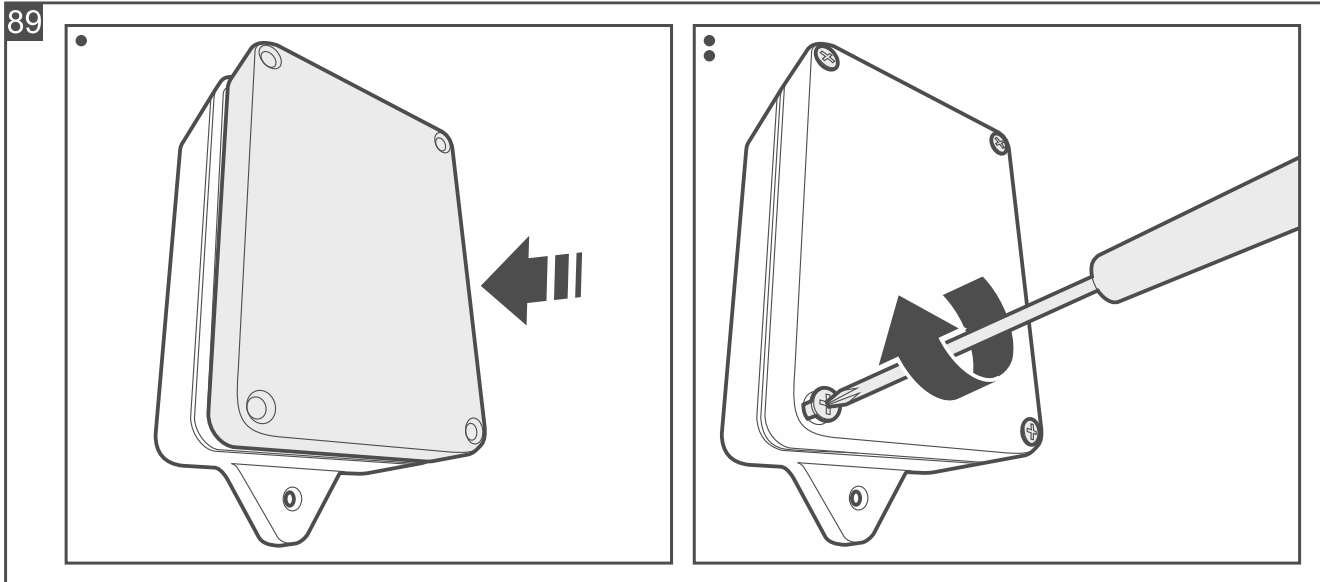

4. Place the detector against the surface and mark the location of the mounting holes.
5. Drill the holes in the surface for wall plugs (anchors). Use wall plugs specifically intended for the mounting surface (different for concrete or brick wall, different for plaster wall, etc.).
6. Secure the detector to the surface with screws (Fig. 90).

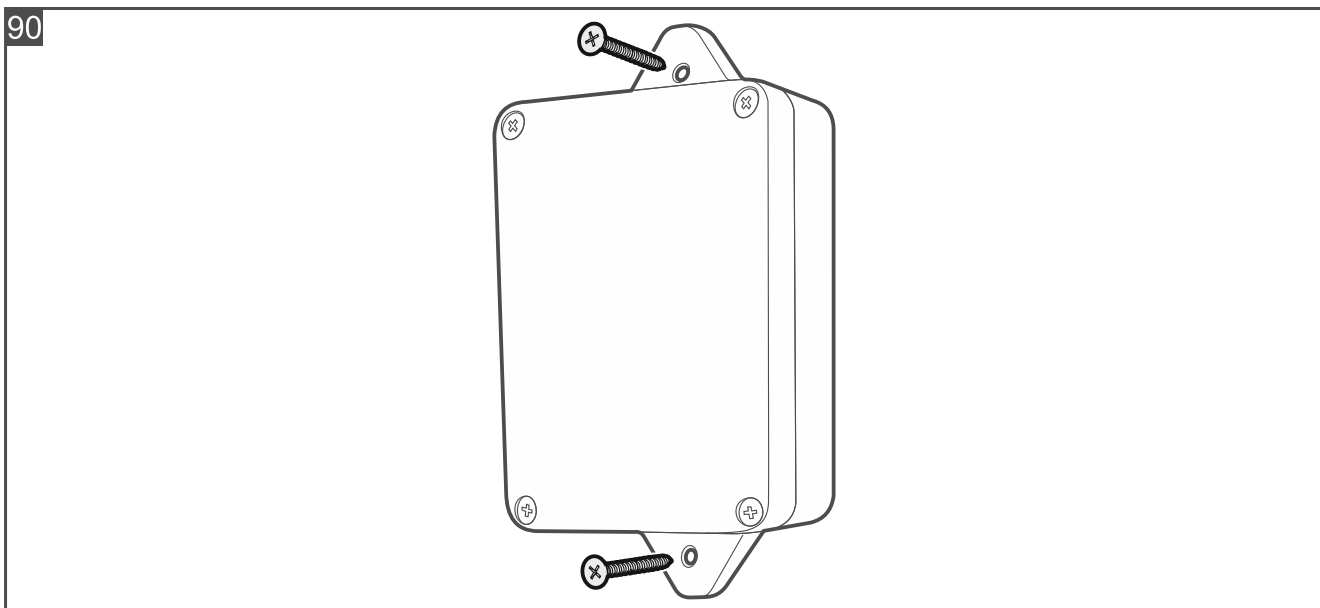

#### 4.5.14 Installing the Multi Sensor

##### Installation tips for the Multi Sensor

- The detector should be installed indoors, in spaces with normal air humidity.
- Do not install the detector outdoors.

##### Mounting the Multi Sensor



*The figures show the detector mounted vertically, but it may be mounted in any position (it has no effect on its operation).*

1. Open the detector enclosure (Fig. 91). The enclosure opening tool, shown in the figure, is provided with the detector.

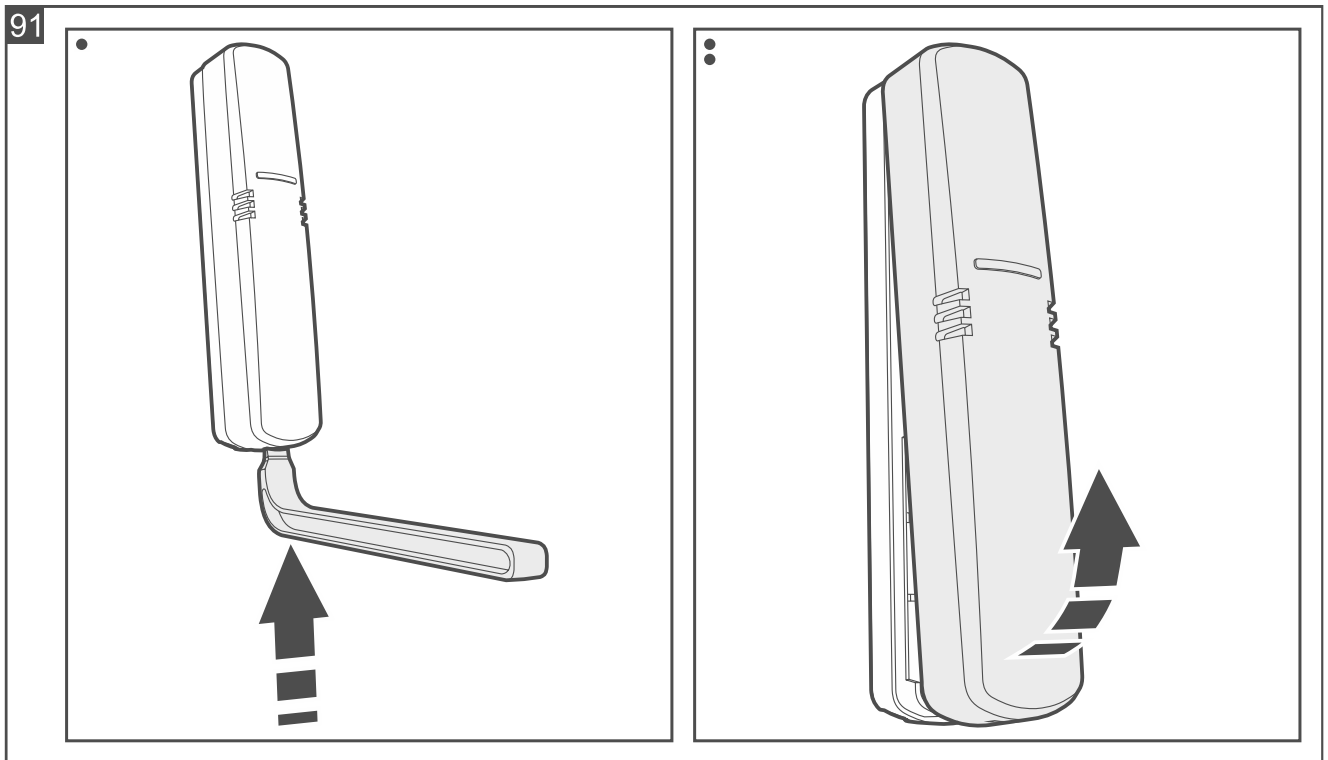

2. If the detector is to be mounted on the surface using a double-sided mounting tape (Fig. 92):
  - stick the tape to the enclosure base.
  - stick the enclosure base to the surface.

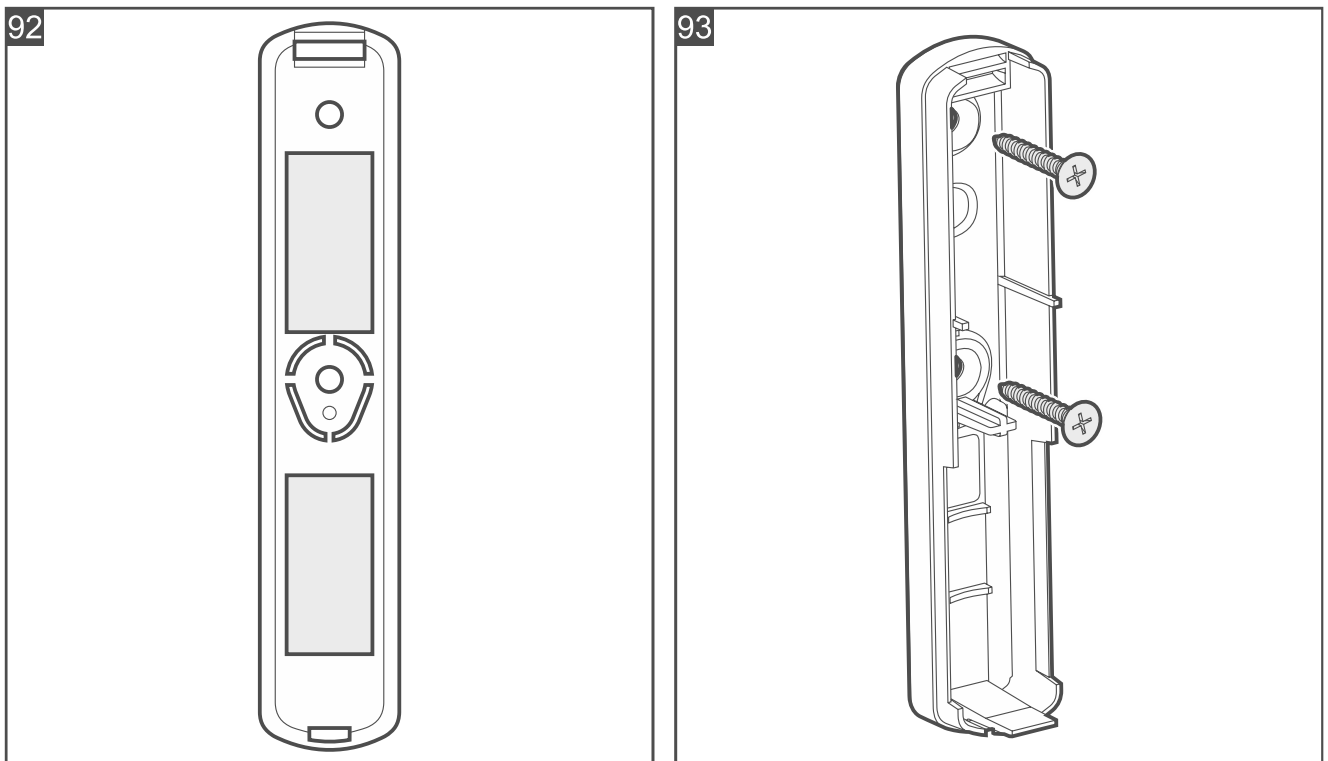

3. If the detector is to be mounted on the surface with screws:
  - place the enclosure base against the surface and mark the location of the mounting holes.

- drill the holes in the surface for wall plugs (anchors). The wall plugs provided with the detector are intended for concrete or brick. For other types of surface (drywall, styrofoam), use other appropriately selected wall plugs.
- secure the enclosure base to the surface with screws (Fig. 93).



*If the detector is to detect removal from the surface, secure the detector with screws.*

4. Start the Be Wave app and add the detector to the system. When a request to turn on the device will be displayed, install the battery in the detector.
5. Close the enclosure.

#### 4.5.15 Installing the Outdoor Siren

##### Installation tips for the Outdoor Siren

- Install the siren on the wall, high above the floor, at a hard to access location, so as to minimize the risk of tampering.
- Leave a free space above the siren (at least 2.5 cm). Otherwise, it will be impossible to replace / remove the cover.

##### Mounting the Outdoor Siren



**Never shorten or deform the antenna.**

1. Remove the cover locking screws.
2. Lift up the cover and remove it (Fig. 94).

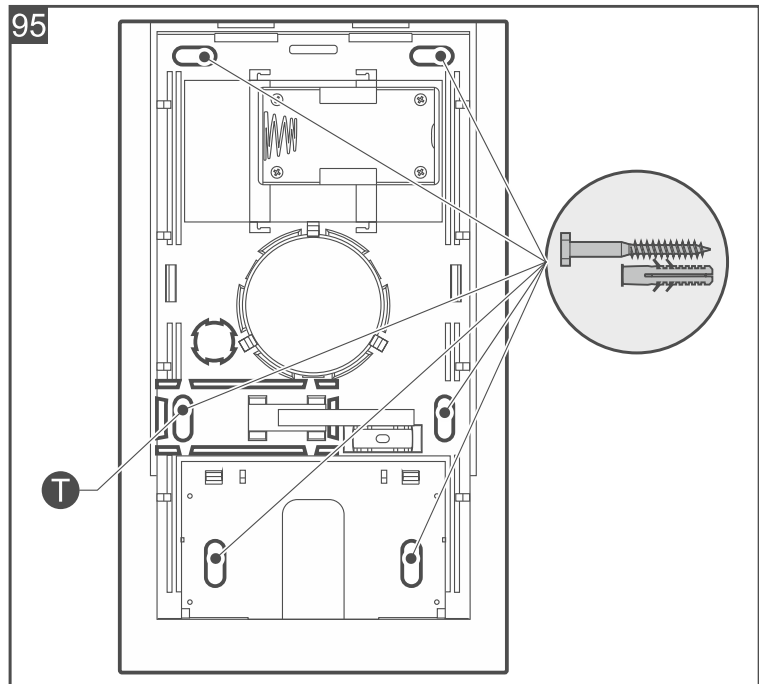
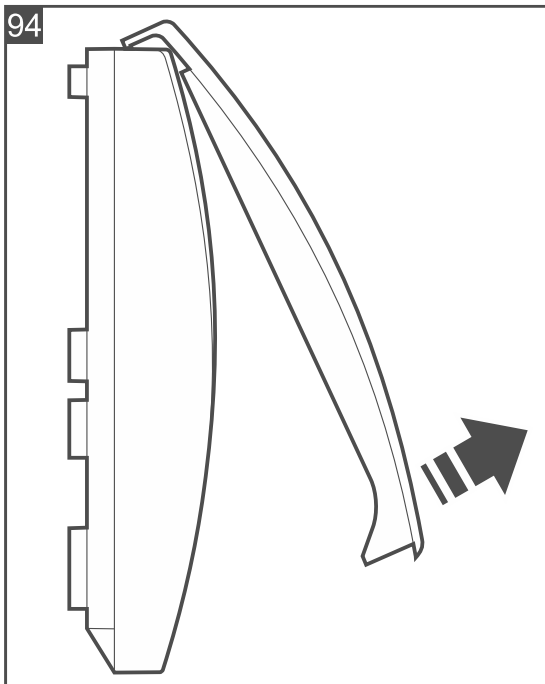

3. Move aside the catches holding the electronics module and remove it.
4. Place the enclosure base against the wall and mark the location of mounting holes (Fig. 95). If the siren is to detect removal from the surface, mark the location of the hole in the tamper protection element (marked with the **T** symbol in the figure).



*The siren must detect removal from the surface if it is to meet the requirements of Standard EN 50131 for Grade 2.*

5. Drill the holes in the wall for wall plugs (anchors). Use wall plugs specifically intended for the mounting surface (different for concrete or brick wall, different for plaster wall, etc.).

- Secure the enclosure base to the wall with screws. If the siren is to detect removal from the surface, secure also the tamper protection element.
- Fasten the electronics module in the enclosure base.
- Connect the battery holder to the electronics module (Fig. 96).

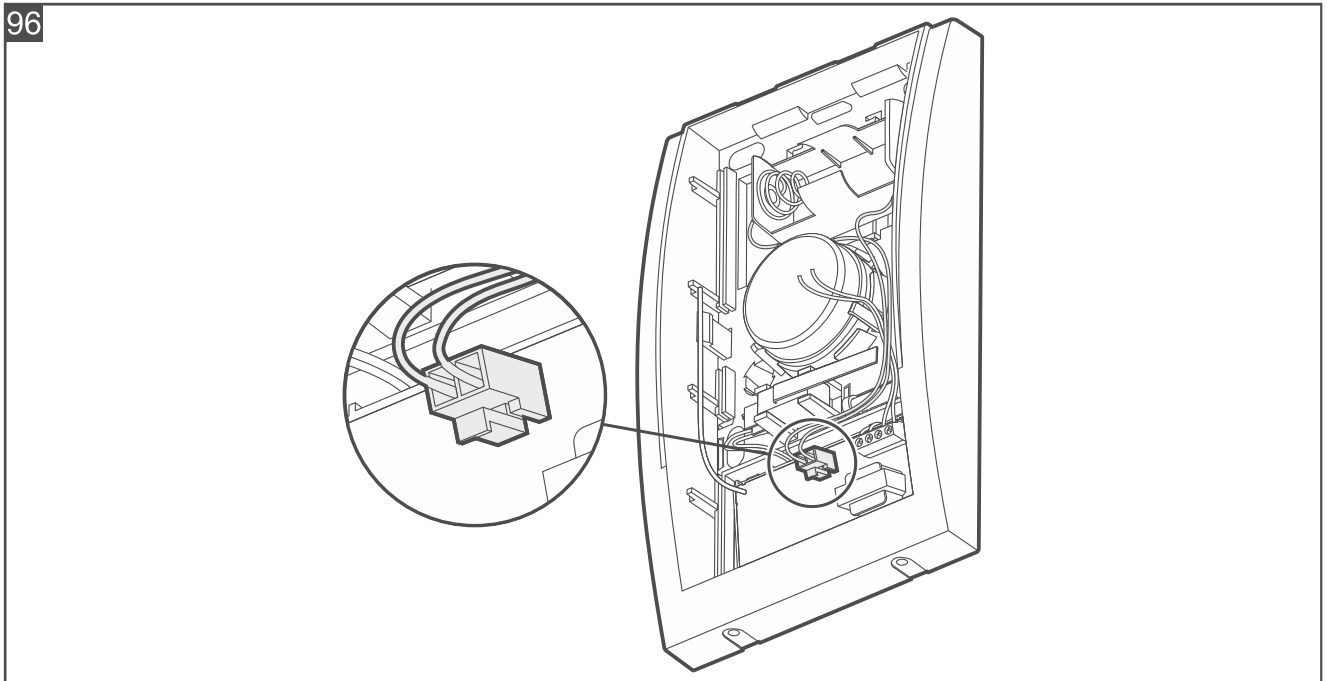

- Start the Be Wave app and add the siren to the system. When a request to turn on the device will be displayed, install the battery in the siren.



*When the battery is installed, the leftmost LED will start flashing to indicate that the battery initialization procedure has begun. Given the specific nature of the battery, it must be properly initialized to reach the required performance. When the battery is being initialized, you can add the siren to the system but the siren will not be ready for normal work until the LED stops flashing.*

- Replace the siren cover and lock it with a screw.

#### 4.5.16 Installing the Indoor Siren

##### Installation tips for the Indoor Siren

- The siren should be installed indoors, in spaces with normal air humidity.
- Do not install the siren outdoors.
- Install the siren on the wall, high above the floor, at a hard to access location, so as to minimize the risk of tampering.
- Leave a free space above the siren (at least 1 cm). Otherwise, it will be impossible to replace / remove the cover.

##### Mounting the Indoor Siren



**Never shorten or deform the antenna.**

- Remove the cover locking screws.

2. Lift up the cover and remove it (Fig. 97).

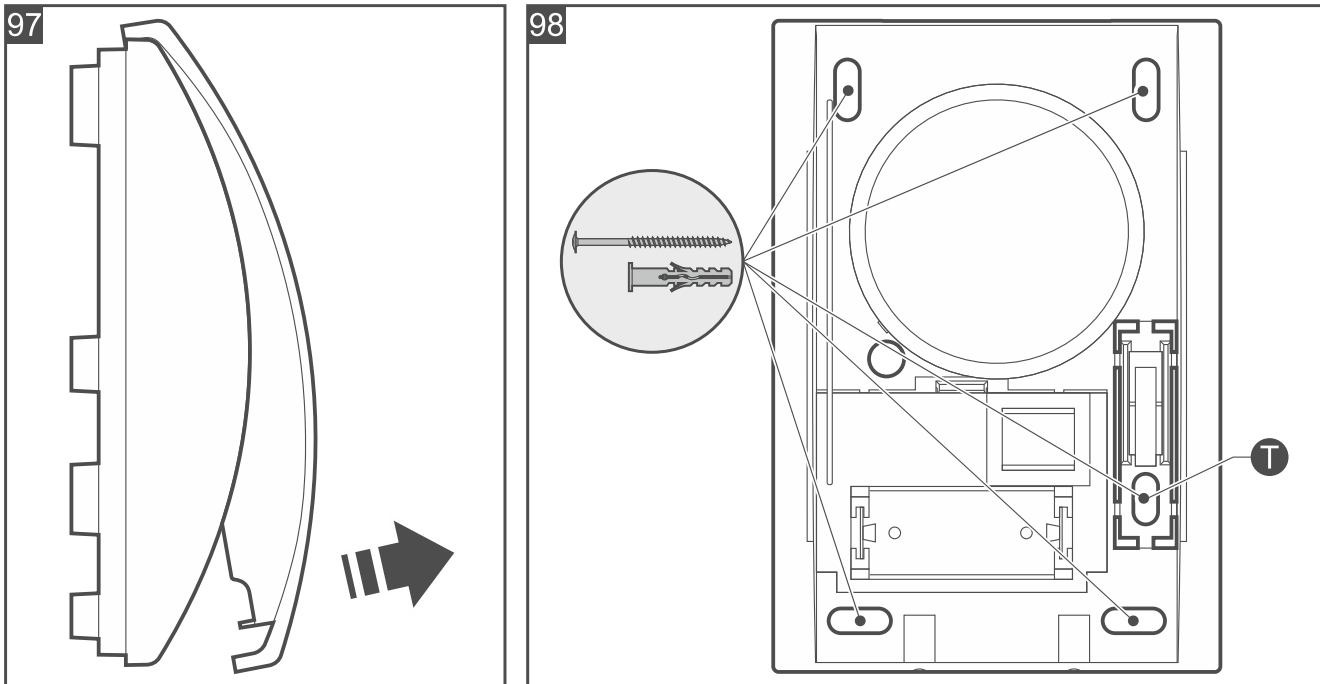

3. Place the enclosure base against the wall and mark the location of mounting holes (Fig. 98). If the siren is to detect removal from the surface, mark the location of the hole in the tamper protection element (marked with the **T** symbol in the figure).



*The siren must detect removal from the surface if it is to meet the requirements of Standard EN 50131 for Grade 2.*

4. Drill the holes in the wall for wall plugs (anchors). The wall plugs provided with the siren are intended for concrete or brick. For other types of surface (drywall, styrofoam), use other appropriately selected wall plugs.
5. Secure the enclosure base to the wall with screws. If the siren is to detect removal from the surface, secure also the tamper protection element.
6. Start the Be Wave app and add the siren to the system. When a request to turn on the device will be displayed, install the battery in the siren.
7. Replace the siren cover and lock it with a screw.

#### 4.5.17 Installing the Mini Multi Extender



**Disconnect power before making any electrical connections.**

**To power the expander, use a 4...24 VDC power supply with current limitation up to 3 A.**

**Do not use the battery to power the expander.**

## Description of the Mini Multi Extender

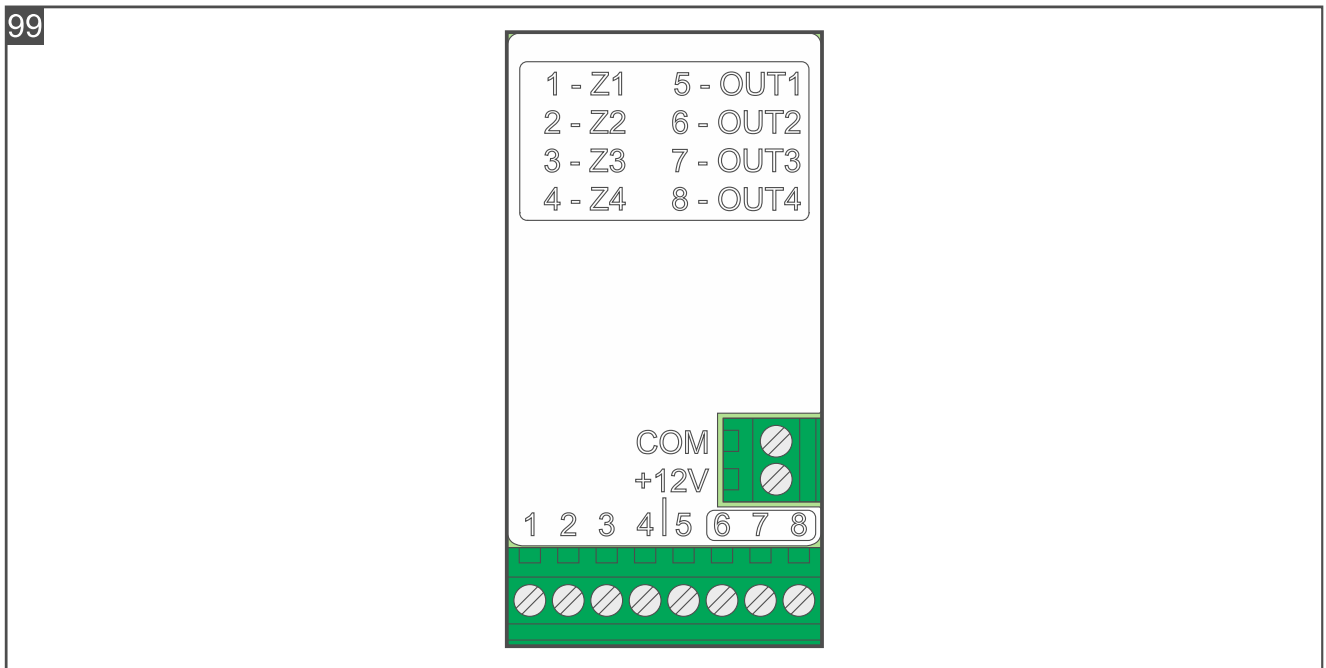

### Terminals

**COM** - common ground.

**+12V** - power input.

**1...4** - zones Z1...Z4.

**5...8** - outputs OUT1...OUT4. The outputs are OC type. When the output is turned off, it is disconnected from the common ground (high impedance). When the output is turned on, it is shorted to common ground (0 V).



*Given the specific character of radio communication, it is not recommended that the expander be used in applications where quick switching of the output status is required.*

### Installation tips for the Mini Multi Extender

- The expander should be installed indoors, in spaces with normal air humidity.
- Do not install the expander outdoors.
- To connect devices to the expander terminals, use flexible wires with a cross-section of 0.5-0.75 mm<sup>2</sup>.

### Mounting the Mini Multi Extender

1. Connect detectors to the expander zones. If the detector is to operate in the Single EOL configuration, use a 2.2 k $\Omega$  resistor (Fig. 100 and 101). If the detector is to operate in the Double EOL configuration, use two 1.1 k $\Omega$  resistors (Fig. 102).
2. Connect the devices to the expander outputs.
3. Connect the power wires to the +12V and COM terminals.
4. Secure the expander to the mounting surface or, if it is to be installed in the enclosure of another device, place the expander inside that enclosure. You can use a double-sided tape to secure the expander.
5. Start the Be Wave app and add the expander to the system. When a request to turn on the device will be displayed, power up the expander.



Taking into account the requirements of the EN 50131-3 standard, select 400 ms when configuring the sensitivity of alarm zones.

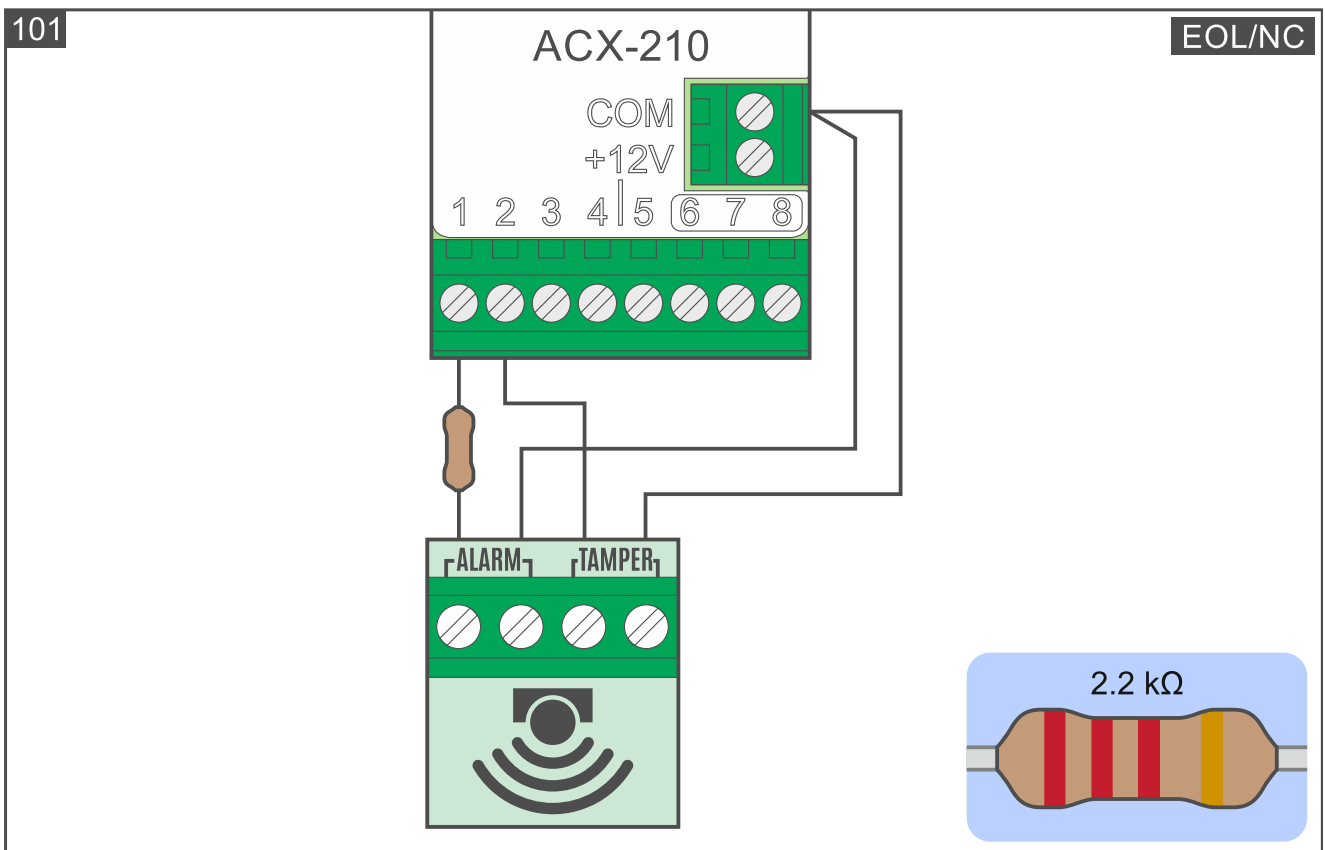
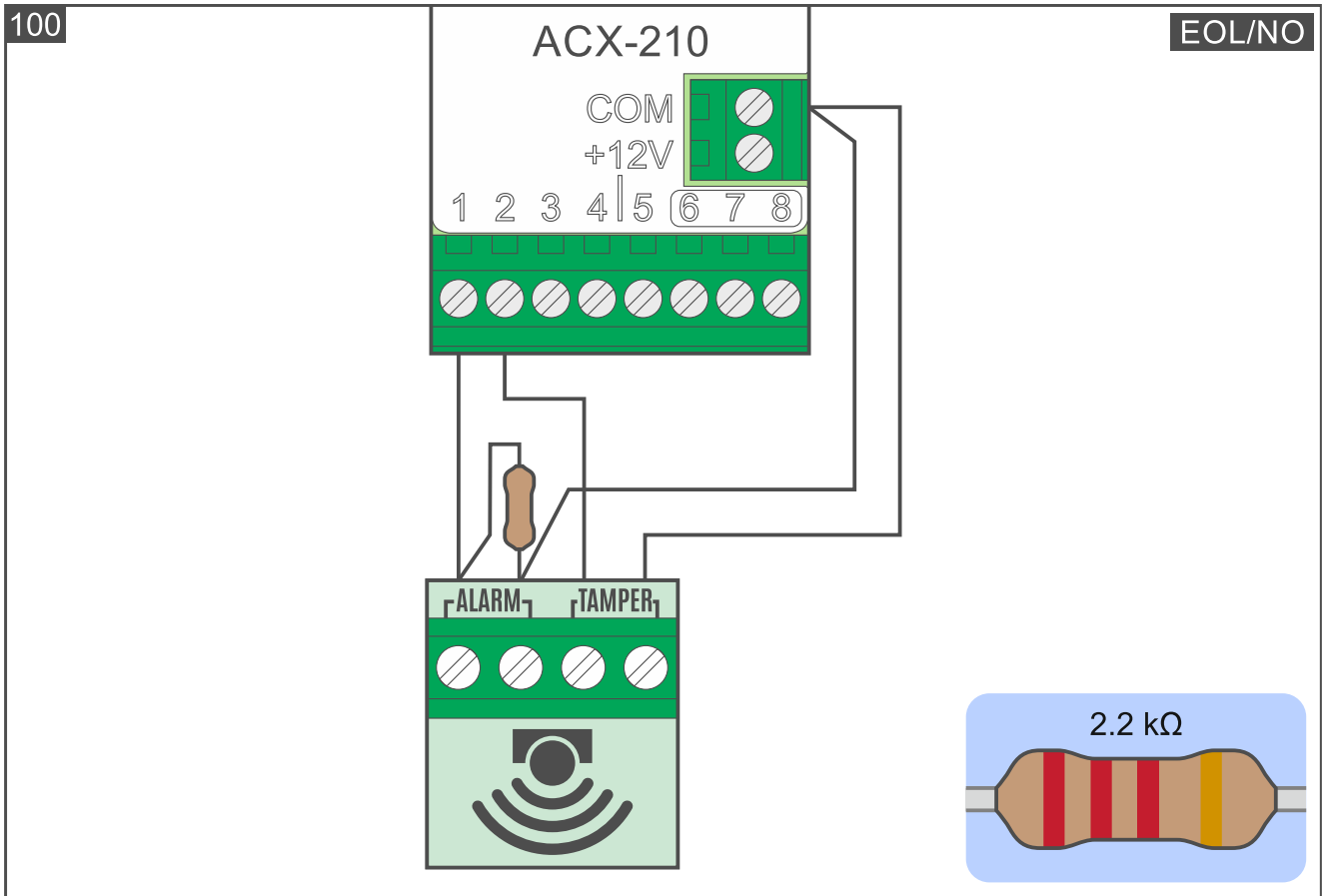

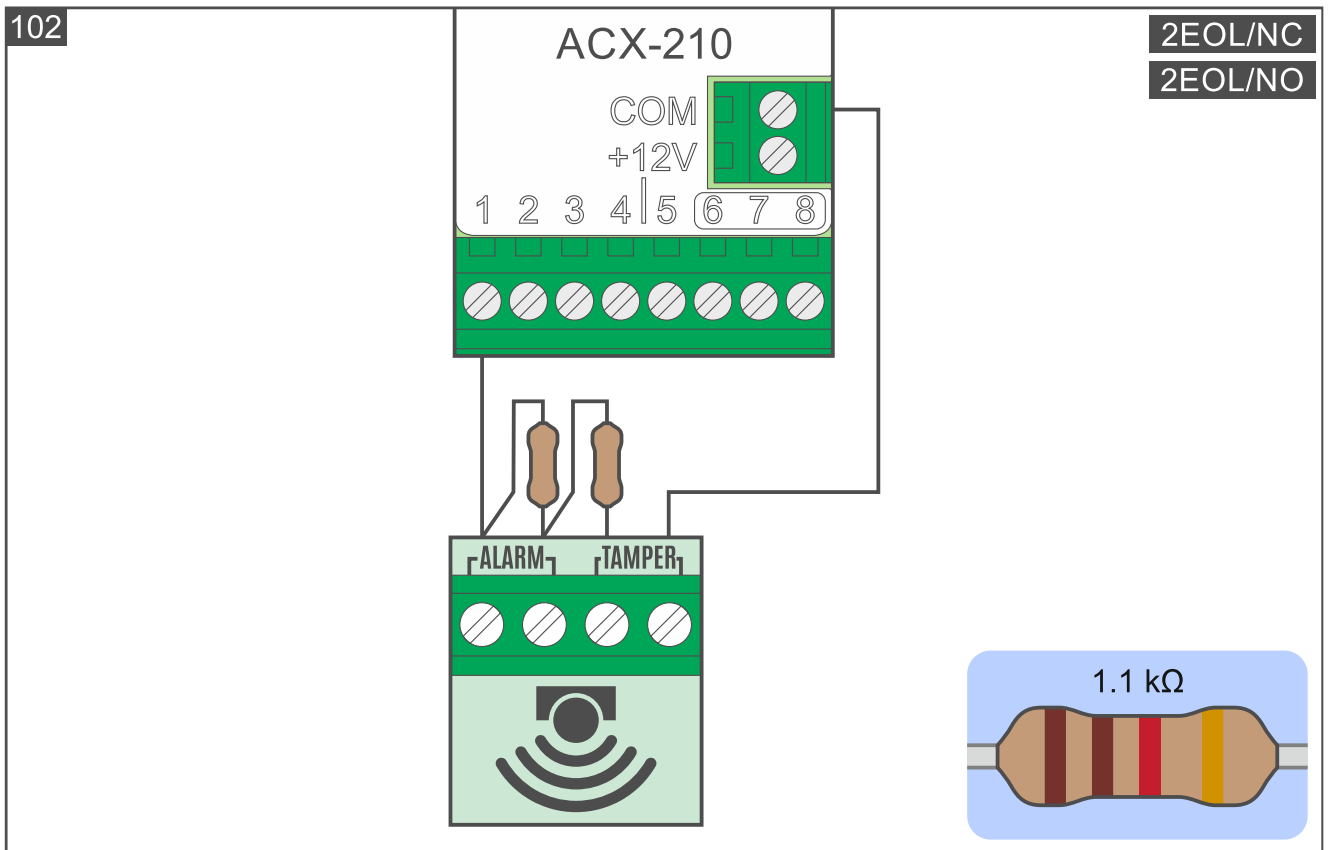

#### 4.5.18 Installing the Multi Extender



Disconnect power before making any electrical connections.

To power the expander, use a 12 VDC power supply (e.g. the SATEL APS-412 power supply).

Never connect power supply to APS connector and terminals at the same time.

## Description of the Multi Extender

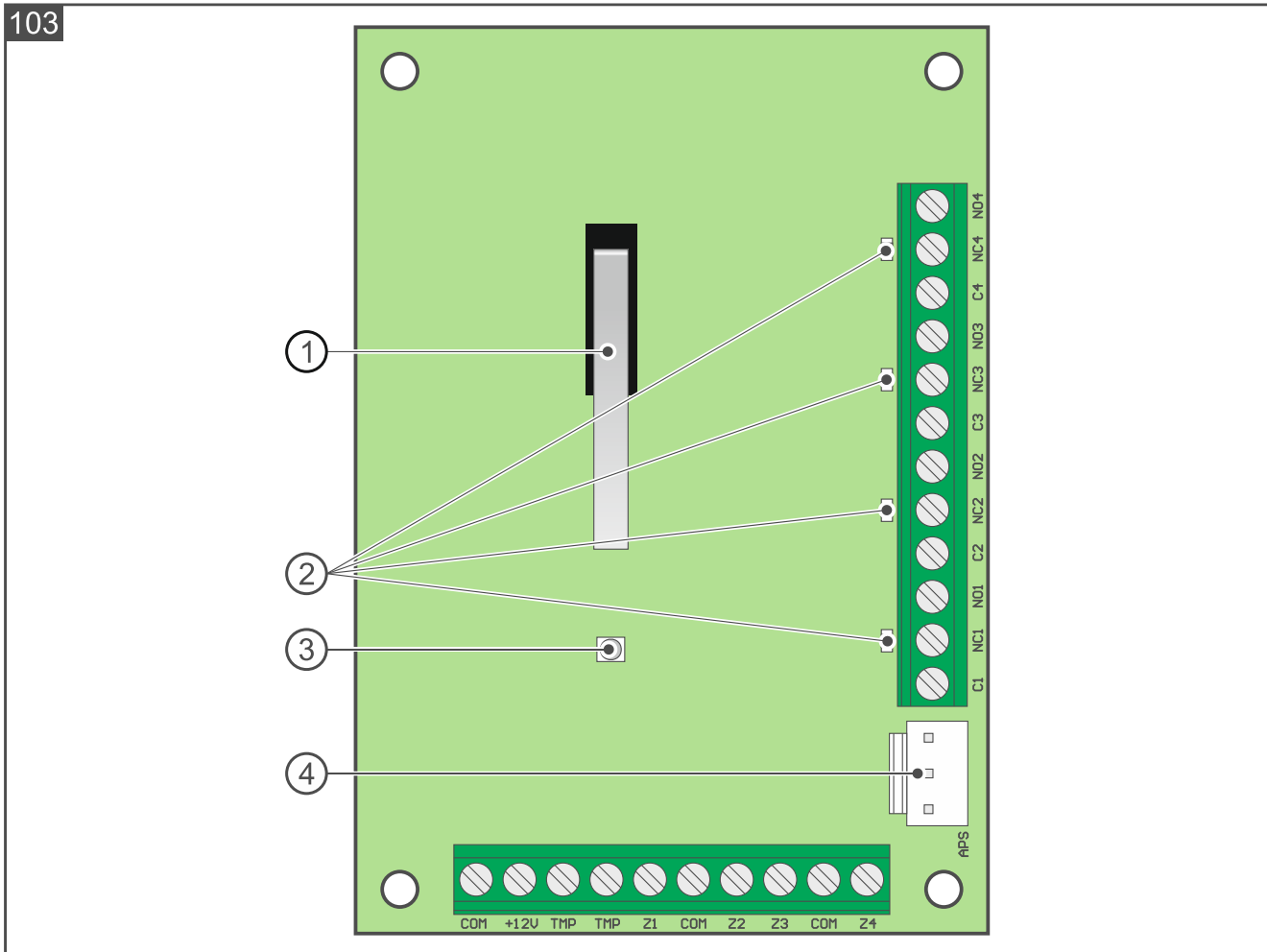

The figure shows the expander electronics board.

- ① tamper switch.
- ② LED indicators to indicate the status of relay outputs:  
OFF – output turned off,  
ON – output turned on.
- ③ LED indicator to indicate the communication with controller (single flash).
- ④ APS connector to connect a SATEL power supply (e.g. APS-412).

### Terminals

- COM** - common ground.
- +12V** - power input / +12 VDC power output when the expander is powered by a power supply connected to the APS connector.
- TMP** - tamper output (NC).
- Z1...Z4** - zone.
- C1...C4** - relay output common contact,
- NC1...NC4** - relay output normally closed contact.
- NO1...NO4** - relay output normally open contact.



Given the specific character of radio communication, it is not recommended that the expander be used in applications where quick switching of the output status is required.

## Installation tips for the Multi Extender

- The expander should be installed indoors, in spaces with normal air humidity.
- Do not install the expander outdoors.
- To connect devices to the expander terminals, use flexible wires with a cross-section of 0.5-0.75 mm<sup>2</sup>.

## Mounting the Multi Extender

1. Loosen the enclosure cover locking screws and remove the cover.
2. Place the enclosure base against the wall and mark the location of mounting holes.
3. Drill the holes in the wall for wall plugs (anchors). Use wall plugs specifically intended for the mounting surface (different for concrete or brick wall, different for plaster wall, etc.).
4. Make the opening(s) for cable(s) in the enclosure base.
5. Pass the cable(s) through the opening(s).
6. Secure the enclosure base to the wall with screws.
7. If the expander is to report enclosure opening (tamper), connect the tamper output to one of the expander zones (connect one TMP terminal to the zone terminal and the other TMP terminal to the COM terminal). Remember to properly configure the zone settings in the Be Wave app.



*The expander must report enclosure opening (tamper) if it is to meet the requirements of Standard EN 50131 for Grade 2.*

8. Connect detectors to the expander zones. If the detector is to operate in the Single EOL configuration, use a 2.2 k $\Omega$  resistor (Fig. 104 and 105). If the detector is to operate in the Double EOL configuration, use two 1.1 k $\Omega$  resistors (Fig. 106).
9. Connect the devices to the expander outputs.
10. Depending on the selected method of expander powering, connect the power supply to the APS connector or connect the power wires to the +12V and COM terminals.
11. Start the Be Wave app and add the expander to the system. When a request to turn on the device will be displayed, power up the expander.
12. Replace the cover and lock it with screws.



*Taking into account the requirements of the EN 50131-3 standard, select 400 ms when configuring the sensitivity of alarm zones.*

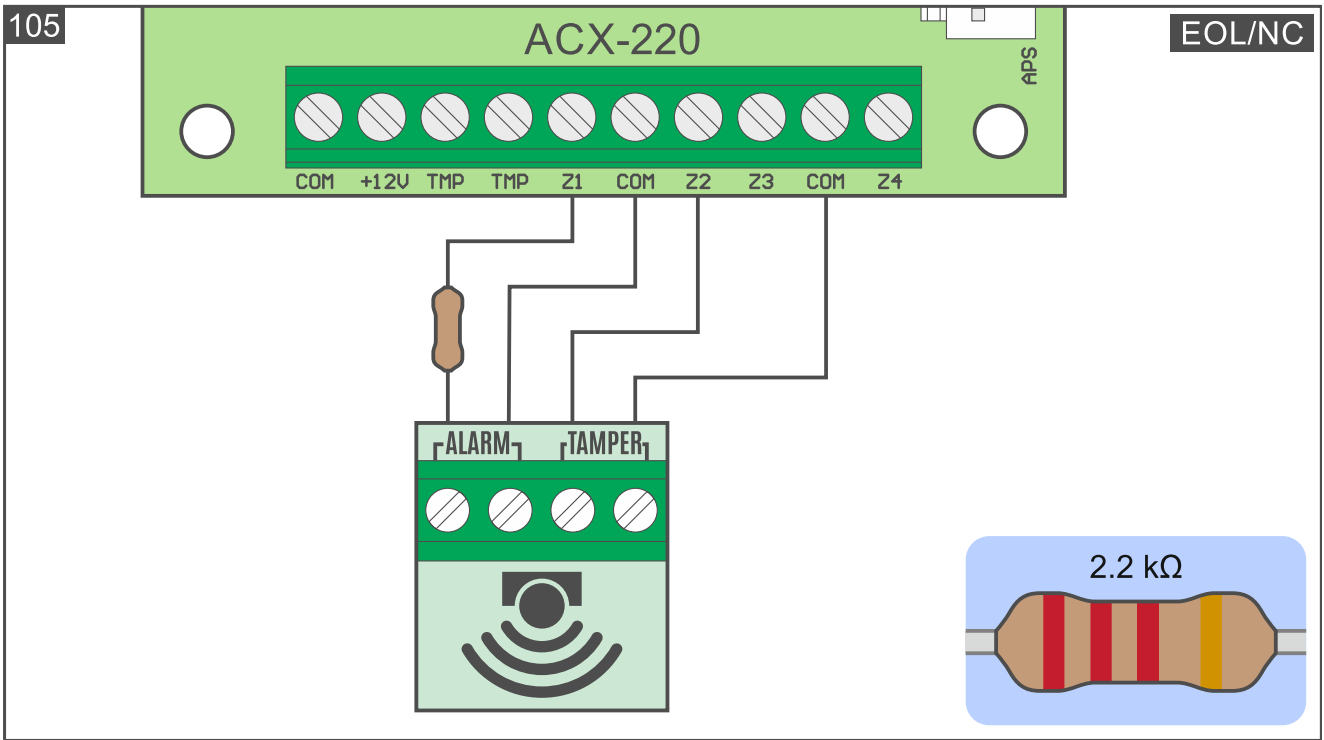
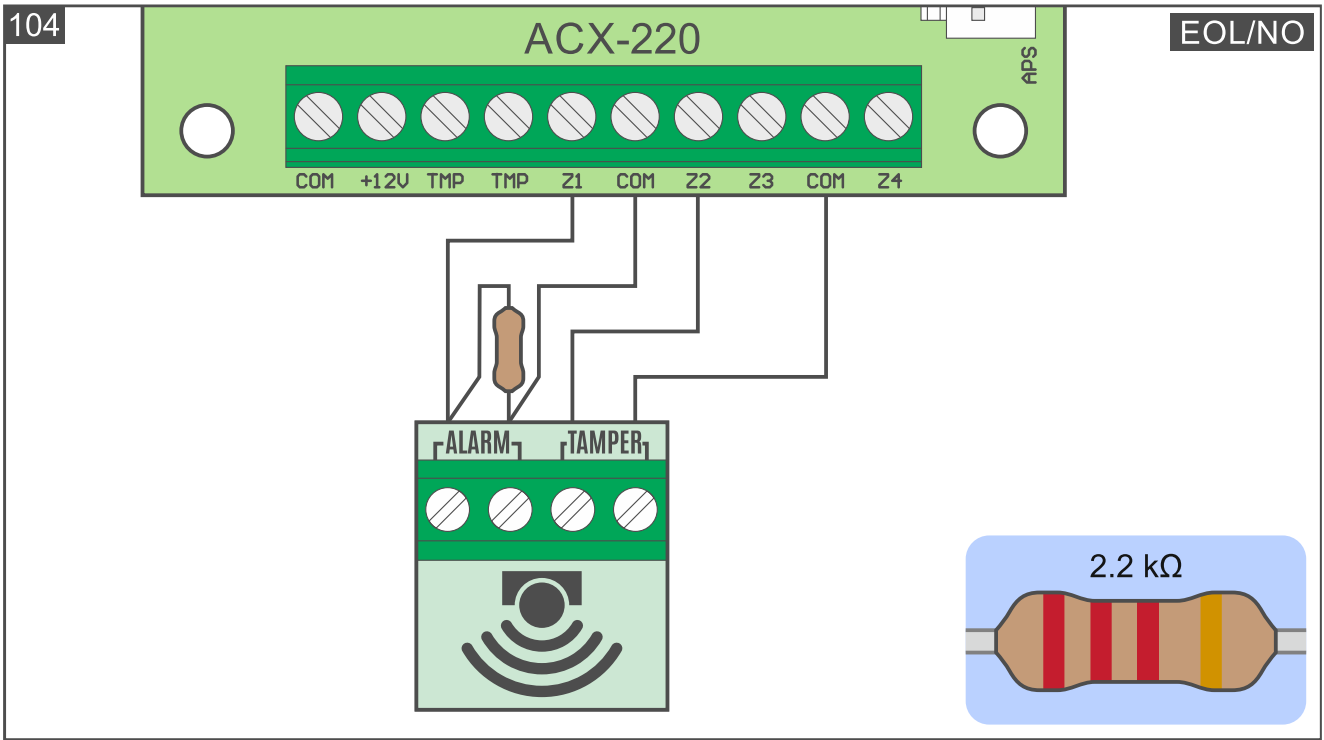

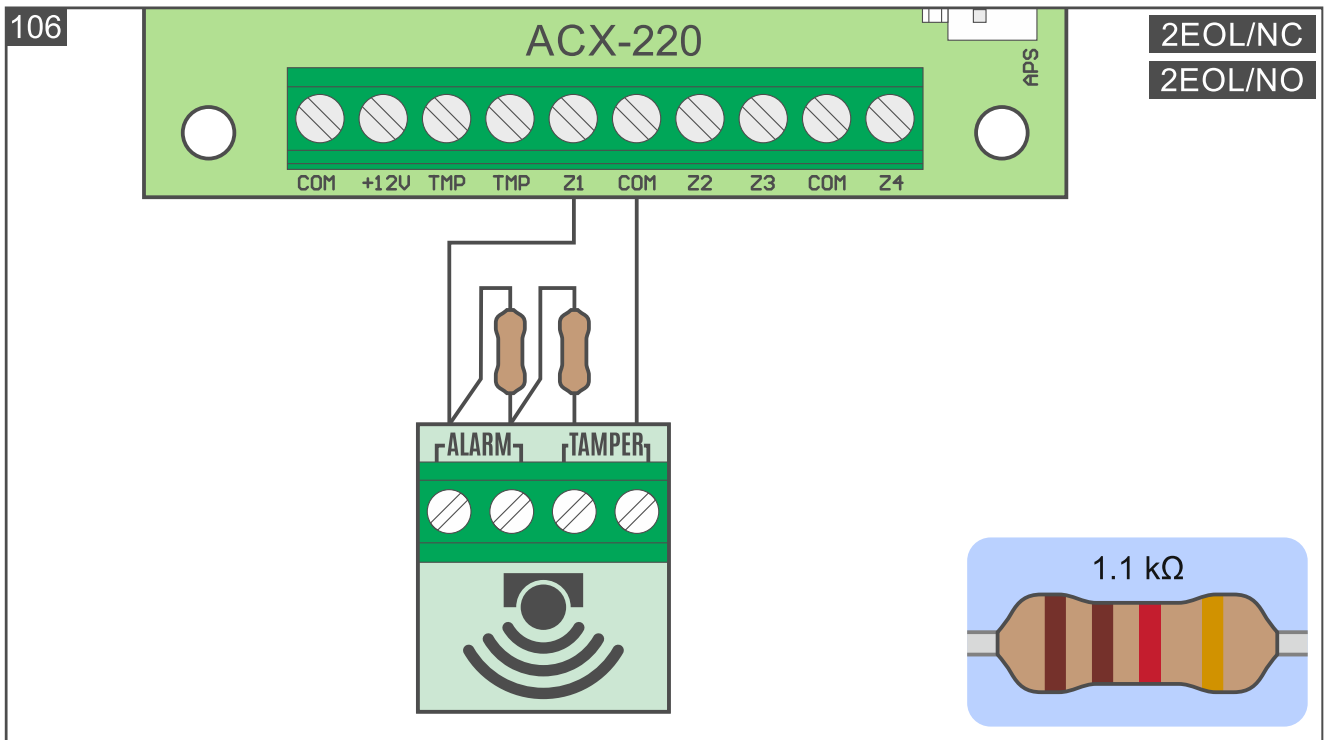

#### 4.5.19 Installing the Smart Dimmer



The device should be installed by qualified personnel.

Disconnect power before making any electrical connections.

Connect the dimmer to a single-phase network according to the applicable standards.

Do not remove the dimmer from the enclosure. Installing the dimmer without enclosure or with a damaged enclosure poses a risk of electric shock and may damage the device.

Do not use the dimmer to dim the lighting powered by DC because this may damage the dimmer and the connected lighting device.

Do not install the dimmer at locations above 2000 m above sea level.

## Description of the Smart Dimmer

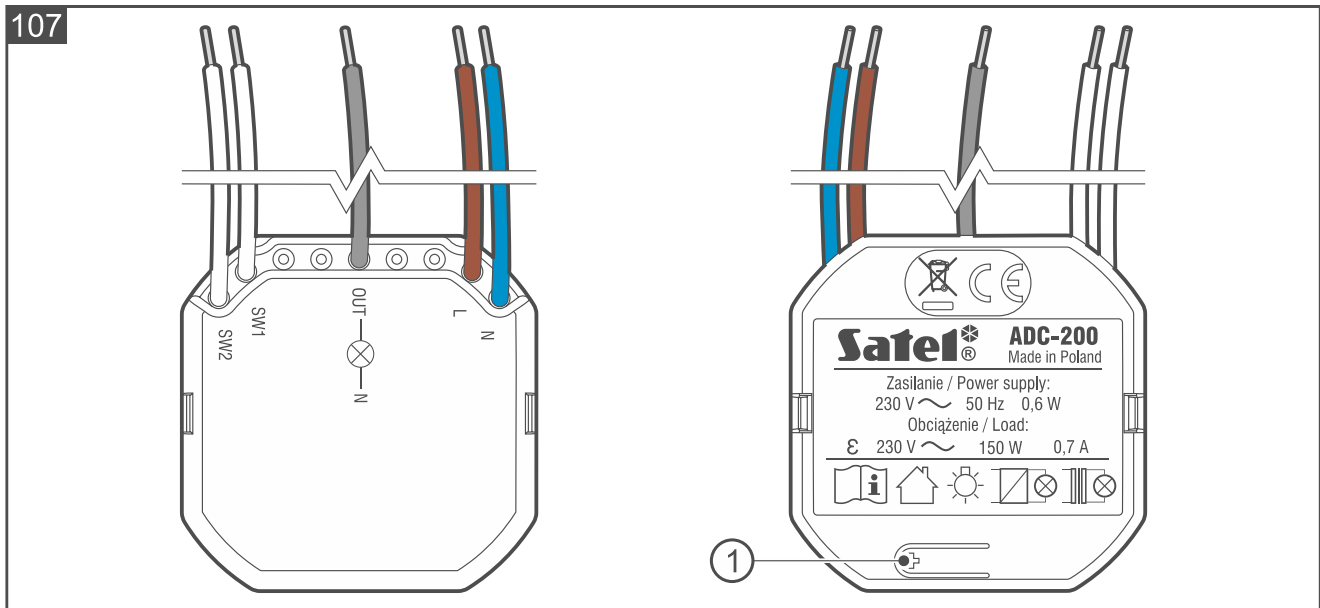

① button used to:

- register the dimmer in the system – press while adding the dimmer to the system,
- block / unblock the registration – press and hold for 10 seconds to block / unblock the capability to add the dimmer to the system.

### Wires

- N** [blue] - for connecting 230 VAC supply neutral wire.  
**L** [brown] - for connecting 230 VAC supply phase wire.  
**OUT** [gray] - output to control the lighting.  
**SW1** [white] - control input 1.  
**SW2** [white] - control input 2.

**i** | *The dimmer inputs are not galvanically isolated.*

### Installation tips for the Smart Dimmer

- The dimmer should be installed indoors, in spaces with normal air humidity.
- Do not install the dimmer outdoors.
- The electrical circuit to which the dimmer is to be connected must have suitable protection. Instruct the owner / user of the system on how to disconnect the dimmer from the mains supply (e.g. indicate the fuse or circuit breaker protecting the dimmer supply circuit).
- Install the dimmer in an electrical junction box (a deep junction box with a diameter of at least 60 mm).
- To connect the wires, use screw terminal blocks, splicing connectors, etc.
- You can connect to the dimmer light sources powered by 230 VAC (incandescent bulbs, halogen bulbs, LED bulbs) or light sources powered by electronic or magnetic transformer.
- Never connect to the dimmer different types of loads simultaneously.
- If you are connecting a LED light bulb, make sure it is dimmable.
- Do not connect more than one transformer to the dimmer output.

- If a magnetic transformer is connected to the dimmer output, make sure the load of the transformer is at least 50% of its rated power.
- Do not connect loads higher than 7 A / 150 W to the dimmer.
- You can connect a push-button or a switch designed for 230 V electrical installations to the dimmer inputs. The push-button is the preferred choice. It provides more functionality.

### Mounting the Smart Dimmer

1. Power off the circuit to which the dimmer is to be connected.
2. Open the electrical junction box in which the dimmer is to be installed.
3. Connect the dimmer to the 230 VAC supply circuit (Fig. 108):
  - brown wire [L] to phase wire.
  - blue wire [N] to neutral wire.
4. Connect the lighting to the dimmer output (Fig. 108).
5. Connect the push-buttons / switches to the dimmer inputs (Fig. 108).
6. Place the dimmer in the junction box. Make sure the wires are behind the dimmer enclosure.
7. Power on the circuit to which the dimmer is connected.
8. Start the Be Wave app and add the dimmer to the system. When a request to turn on the device will be displayed, press the button marked with the + symbol on the enclosure (Fig. 107).
9. Close the junction box.



*If the lighting connected to the dimmer is off after the dimmer is started, the brightness level set in the Be Wave may be too low.*

*In the dimmer settings in the Be Wave app set the minimum brightness level at which it will be visible that the lighting is on.*

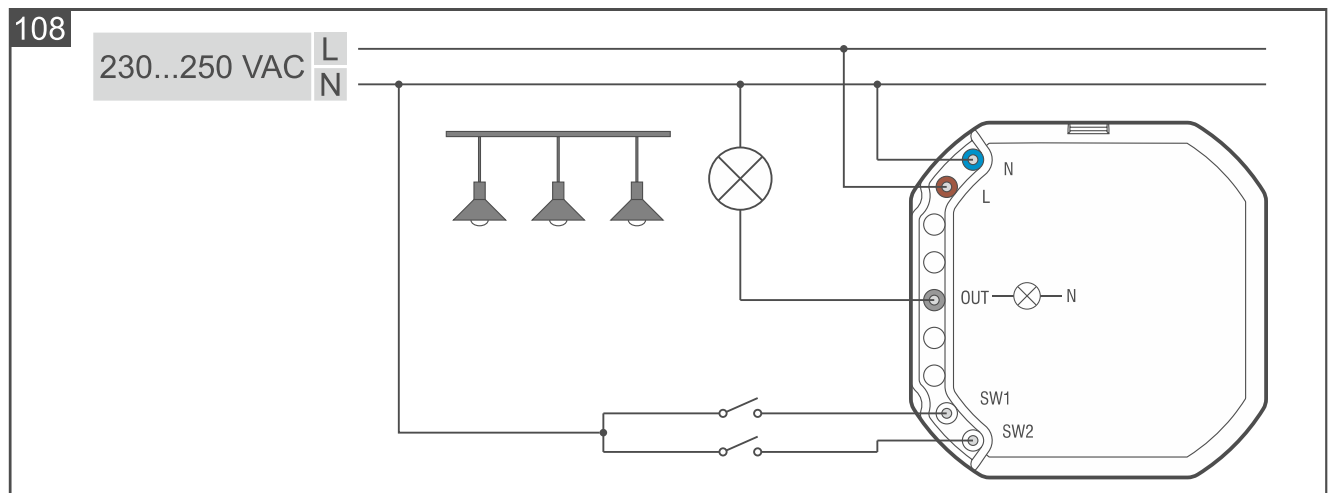

#### 4.5.20 Installing the Smart RGBW LED Driver



**Disconnect power before making any electrical connections.**

**To power the controller, use a 12...48 VDC power supply with current limitation up to 16 A.**

**Do not remove the controller from the enclosure. Installing the controller without enclosure or with a damaged enclosure poses a risk of electric shock and may damage the device.**

**Do not use the controller to control the lighting powered by AC because this may damage the controller and the connected lighting device.**

## Description of the Smart RGBW LED Driver

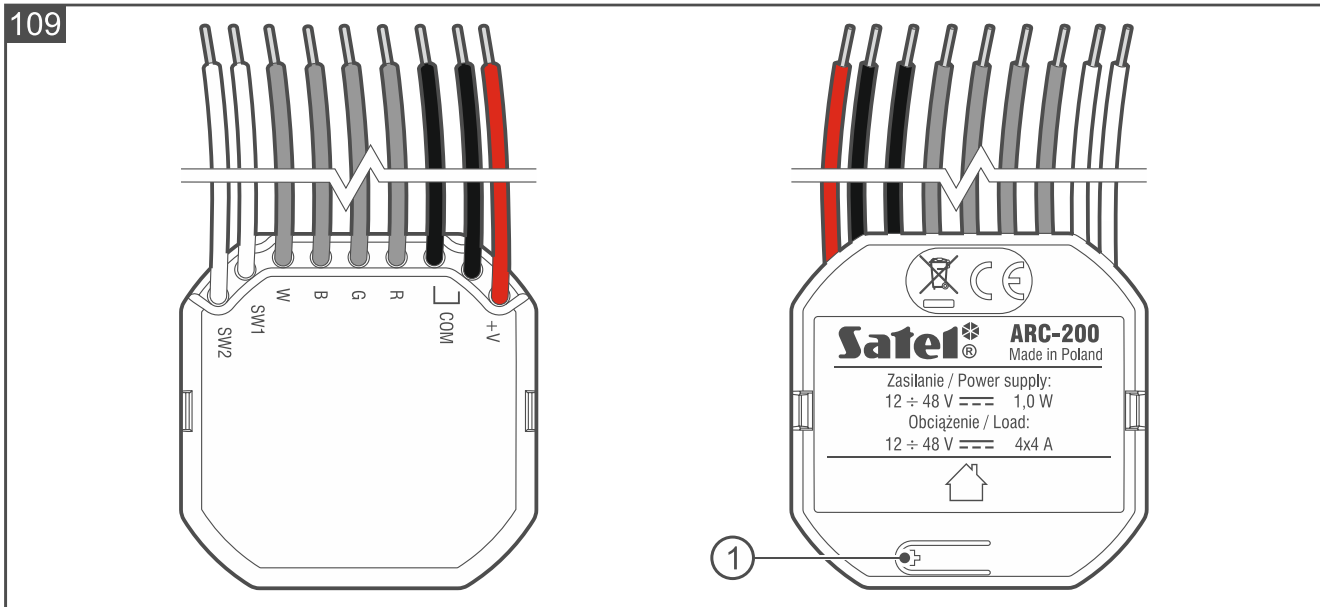

① button used to:

- register the controller in the system – press while adding the controller to the system,
- block / unblock the registration – press and hold for 10 seconds to block / unblock the capability to add the controller to the system.

### Wires

- +V** [red] - for connecting a 12...48 VDC power wire.
- COM** [black] - for connecting the common ground wire.
- R** [gray] - output to control the red color.
- G** [gray] - output to control the green color.
- B** [gray] - output to control the blue color.
- W** [gray] - output to control the white color.
- SW1** [white] - control input 1.
- SW2** [white] - control input 2.

### Installation tips for the Smart RGBW LED Driver

- The controller should be installed indoors, in spaces with normal air humidity.
- Do not install the controller outdoors.
- Install the controller in an electrical junction box (a deep junction box with a diameter of at least 60 mm).
- The controller can control:
  - 1 RGBW LED strip,
  - 1 RGB LED strip,
  - 2 CCT LED strips (cool/warm),

- 4 single color LED strips,
- 4 groups of LED bulbs / halogen bulbs.
- The current consumption by the lighting connected to one controller output cannot exceed:
  - 4 A / 12...48 VDC when all 4 outputs are used,
  - 8 A / 12...24 VDC when 2 outputs are used.
- To connect the wires, use screw terminal blocks, splicing connectors, etc.
- You can connect a push-button or a switch to the controller inputs. The push-button is the preferred choice. It provides more functionality.

### Mounting the Smart RGBW LED Driver

1. Power off the circuit to which the controller is to be connected.
2. Open the electrical junction box in which the controller is to be installed.
3. Connect the controller to the 12...48 VDC supply circuit (Fig. 110 / 111 / 112 / 113 / 114).
4. Connect the lighting to the controller outputs:
  - Fig. 110 – RGBW LED strip,
  - Fig. 111 – RGB LED strip,
  - Fig. 112 – CCT LED strips (cool/warm) – R and B outputs control the warm color (W), G and W outputs control the cool color (C),
  - Fig. 113 – single color LED strips – each output controls the lighting,
  - Fig. 114 – LED bulbs / halogen bulbs – each output controls the lighting.
5. Connect the push-buttons / switches to the controller inputs (Fig. 110 / 111 / 112 / 113 / 114).
6. Place the controller in the junction box. Make sure the wires are behind the controller enclosure.
7. Power on the circuit to which the controller is connected.
8. Start the Be Wave app and add the controller to the system. When a request to turn on the device will be displayed, press the button marked with the + symbol on the enclosure (Fig. 109).
9. Close the junction box.

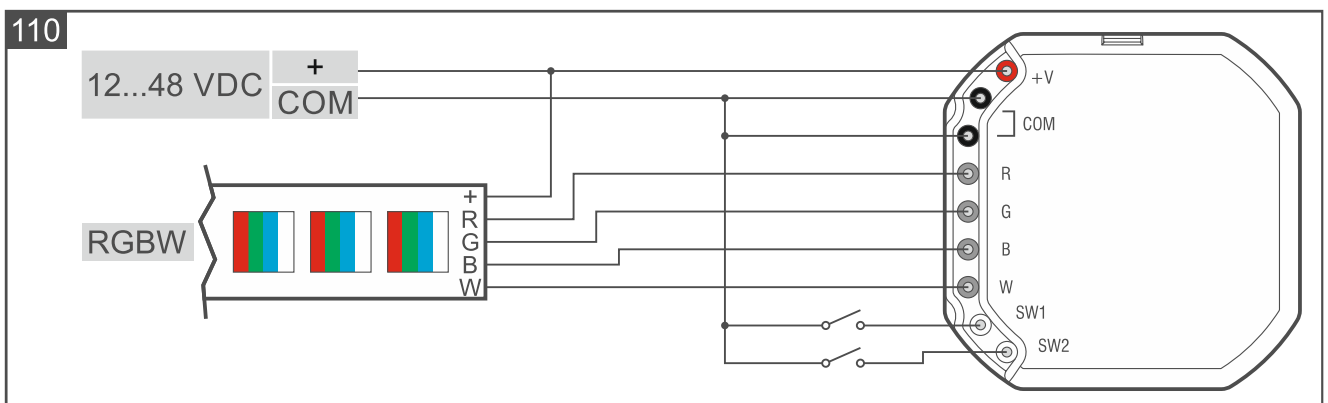

111

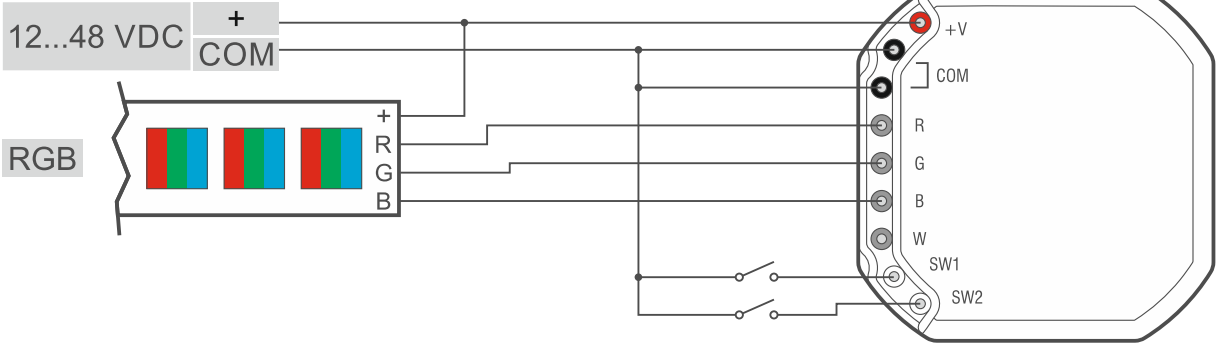

112

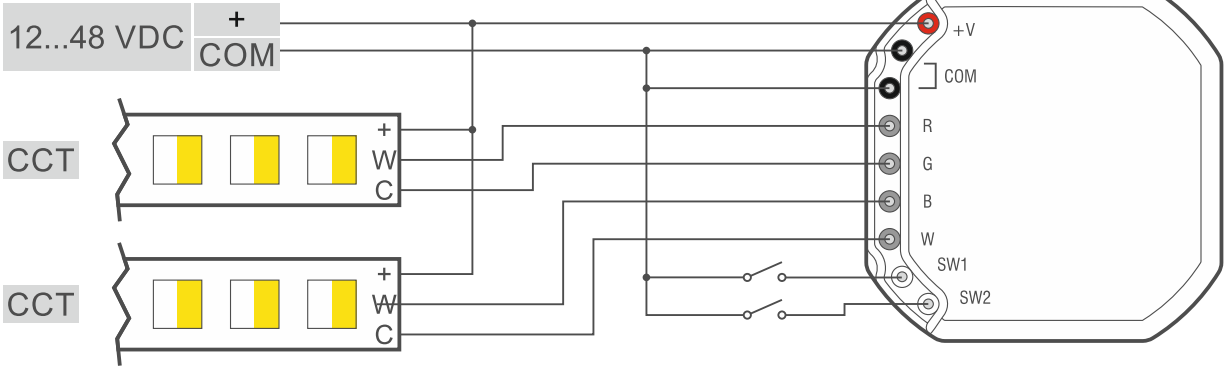

113

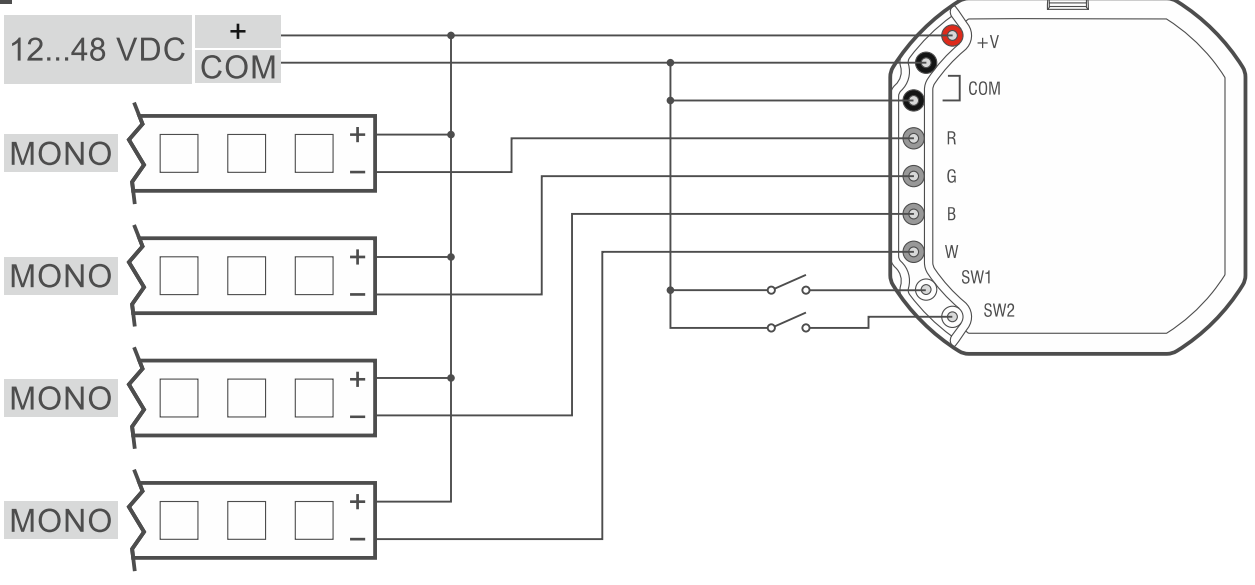

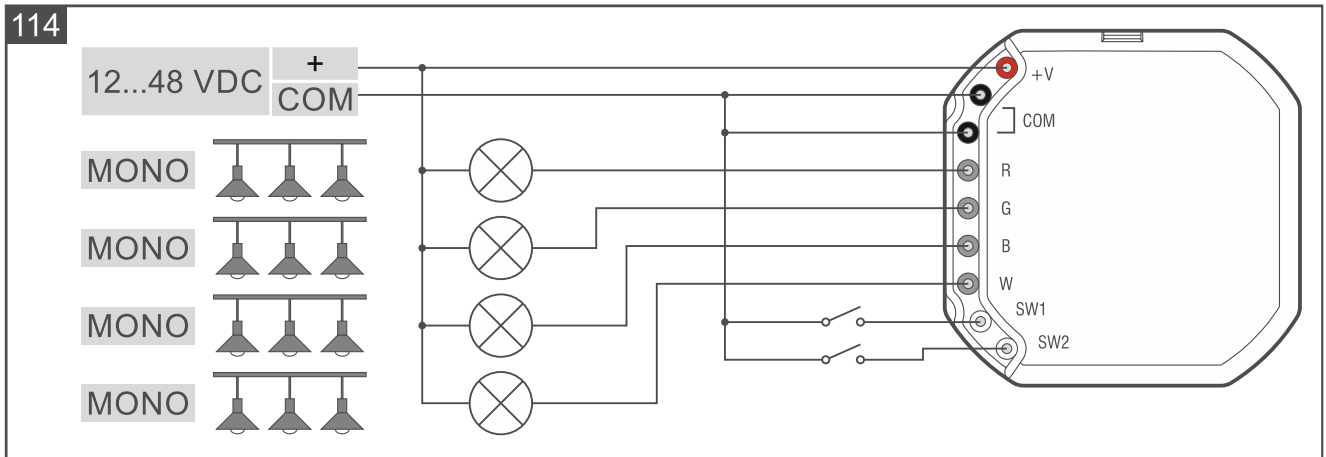

#### 4.5.21 Installing the Smart Blinds



The device should be installed by qualified personnel.

Disconnect power before making any electrical connections.

Connect the controller to a single-phase network according to the applicable standards.

The roller blind / shutter connected to the controller should meet the requirements of standard 60335-2-97.

Do not remove the controller from the enclosure. Installing the controller without enclosure or with a damaged enclosure poses a risk of electric shock and may damage the device.

Do not install the controller at locations above 2000 m above sea level.

#### Description of the Smart Blinds

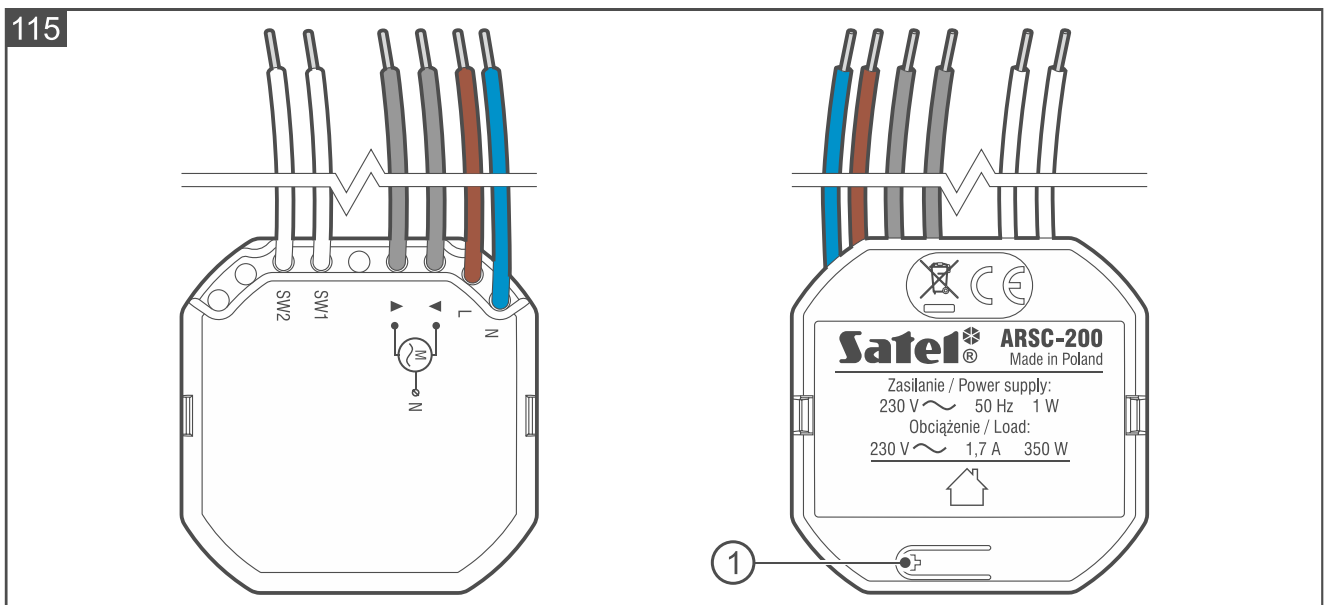

① button used to:

- register the controller in the system – press while adding the controller to the system,
- block / unblock the registration – press and hold for 10 seconds to block / unblock the capability to add the controller to the system.

## Wires

- N** [blue] - for connecting 230 VAC supply neutral wire.
- L** [brown] - for connecting 230 VAC supply phase wire.
- ▼ [gray] - for connecting the blind / shutter motor – downward motion.
- ▲ [gray] - for connecting the blind / shutter motor – upward motion.
- SW1** [white] - control input 1.
- SW2** [white] - control input 2.



*Do not connect more than one blind / shutter motor to the controller.*

*The controller inputs are not galvanically isolated.*

## Installation tips for the Smart Blinds

- The controller should be installed indoors, in spaces with normal air humidity.
- Do not install the controller outdoors.
- The electrical circuit to which the controller is to be connected must have suitable protection. Instruct the owner / user of the system on how to disconnect the controller from the mains supply (e.g. indicate the fuse or circuit breaker protecting the controller supply circuit).
- Install the controller in an electrical junction box (a deep junction box with a diameter of at least 60 mm).
- To connect the wires, use screw terminal blocks, splicing connectors, etc.
- You can connect a 230 VAC blind / shutter motor with limit switches to the controller. The motor's current consumption cannot exceed 1.7 A.
- You can connect a double push-button or a roller blind switch designed for 230 V electrical installations to the controller inputs. The push-button is the preferred choice. It provides more functionality.
- To connect the push-button / switch, use flexible wires with a cross-section of 0.5-0.75 mm<sup>2</sup>.

## Mounting the Smart Blinds

1. Power off the circuit to which the controller is to be connected.
2. Open the electrical junction box in which the controller is to be installed.
3. Connect the controller to the 230 VAC supply circuit (Fig. 116):
  - brown wire [L] to phase wire.
  - blue wire [N] to neutral wire.
4. Connect the blind / shutter motor to the controller output (Fig. 116).

5. Connect a double push-button / roller blind switch to the controller inputs (Fig. 116).

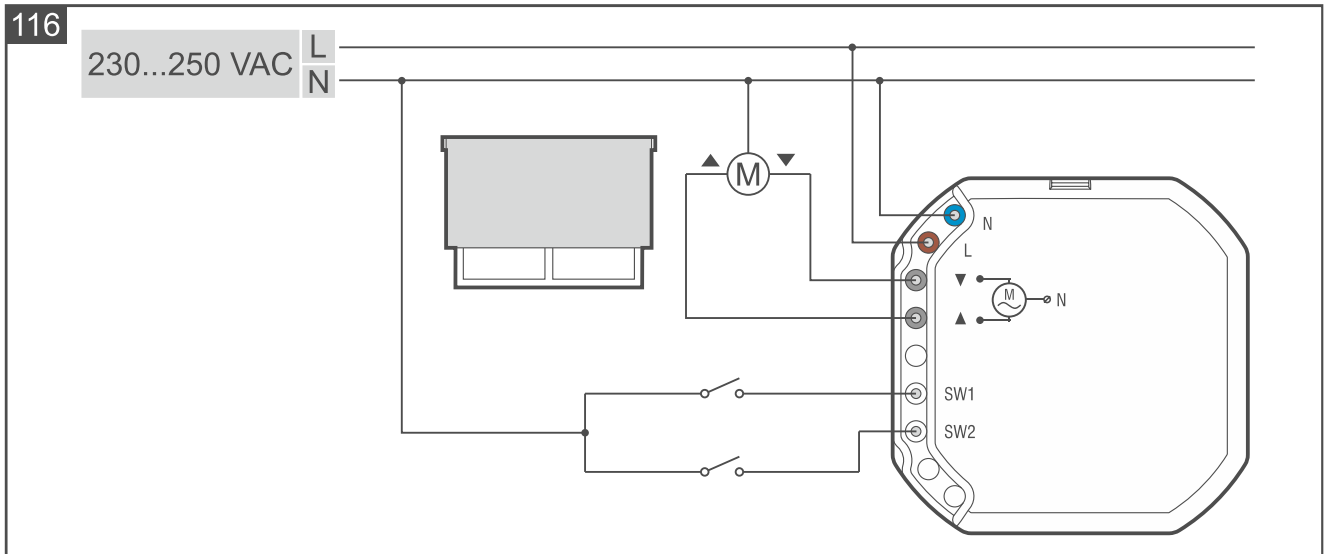

6. Place the controller in the junction box. Make sure the electrical wires are behind the controller enclosure.
7. Power on the circuit to which the controller is connected.
8. Start the Be Wave app and add the controller to the system. When a request to turn on the device will be displayed, press the button marked with the + symbol on the enclosure (Fig. 115).
9. Close the junction box.

#### 4.5.22 Installing the Smart Thermostat

##### Installation tips for the Smart Thermostat

- The thermostat should be installed indoors, in spaces with normal air humidity.
- The thermostat is fitted for radiator valves with the M30 x 1.5 mm threaded connection. It is compatible with most radiator valves on the market.
- In order to install the thermostat on the Danfoss RA, Danfoss RA or Danfoss RAVL valve, use one of the provided adapters.
- The thermostat should be installed in such a way to ensure display visibility and knob accessibility of the knob.
- You do not need any special tools to install the thermostat. Draining the heating system is not required.
- Before you remove the old thermostatic head, make sure to turn it several times from minimum to maximum position and back. Unscrew the old thermostat when it is in the maximum position. When the thermostat is removed, the valve pin should be fully extended.

## Mounting the Smart Thermostat

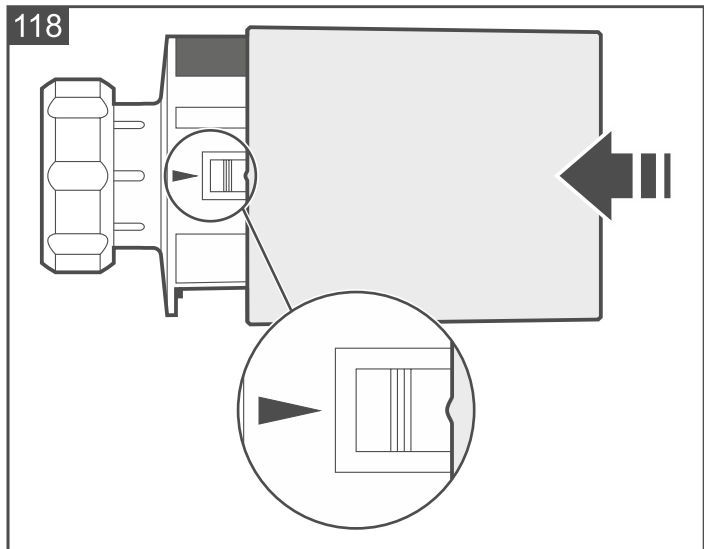
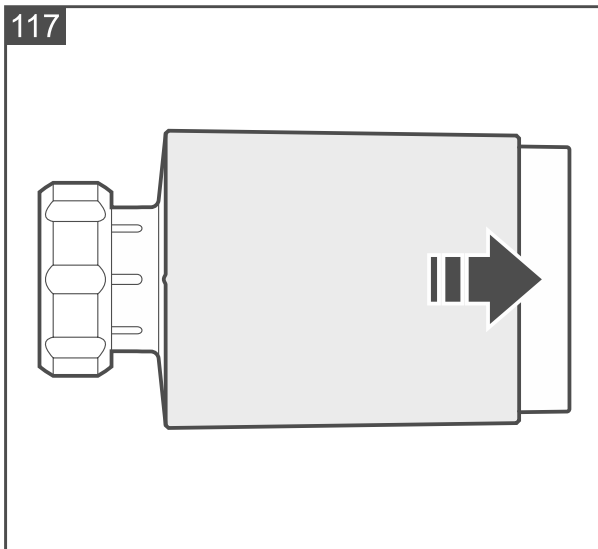

1. Remove the thermostat cover (Fig. 117).



2. Start the Be Wave app and add the thermostat to the system. When a request to turn on the device will be displayed, install two LR6 AA 1.5 V alkaline batteries (they are not supplied with the thermostat).



*When the batteries are installed, the actuator rod that moves the valve pin is completely withheld inside the thermostat cover. If the actuator rod is not completely withheld inside the cover, remove the batteries and install them again.*

*After the thermostat has started, the   message will be displayed. The message indicates that the thermostat is ready for calibration.*

3. Replace the thermostat cover. The marks on the body and cover will help you replace the cover correctly (Fig. 118).
4. Mount the thermostat on the valve (see: “Mounting on M30x1.5 mm valve”, “Mounting on Danfoss RA valve”, “Mounting on Danfoss RAV valve” or “Mounting on Danfoss RAVL valve”).

5. Press the knob (Fig. 119). The thermostat will be calibrated.

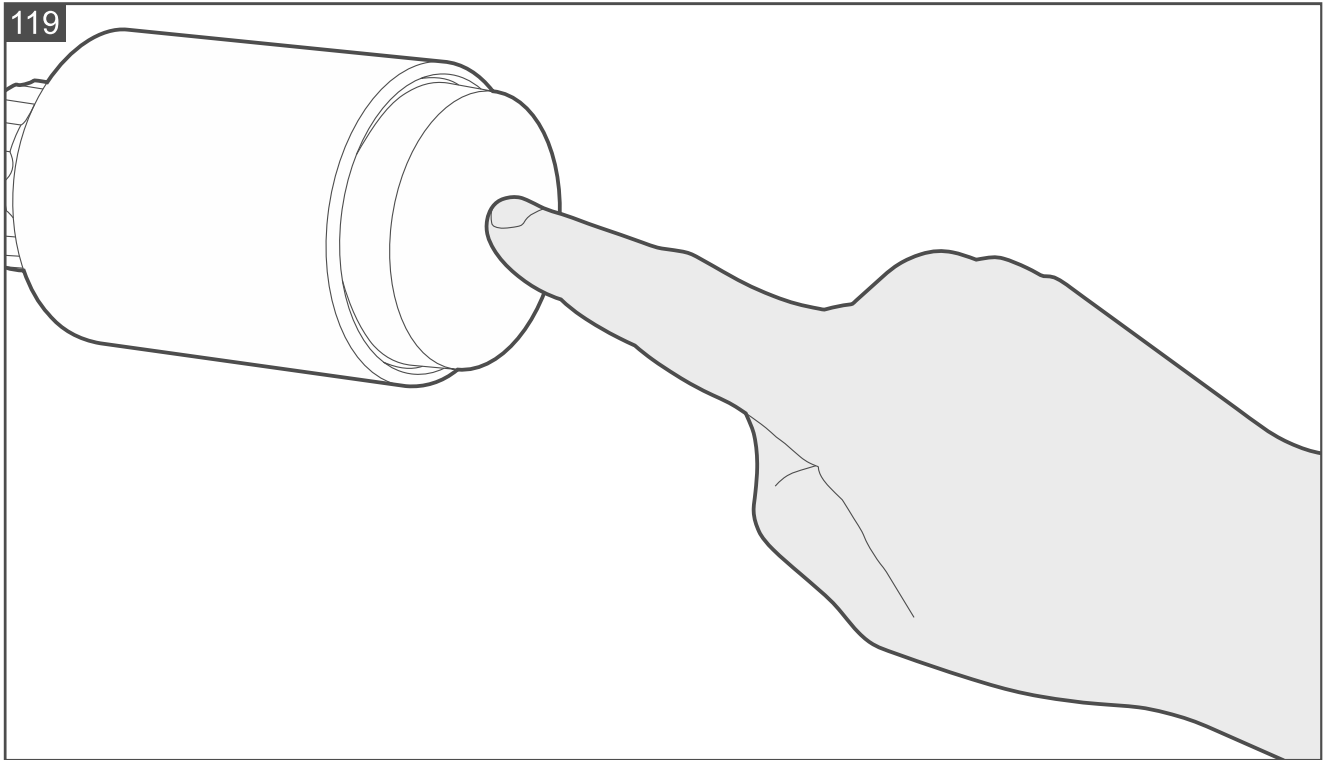

### **Mounting on M30x1.5 mm valve**

1. Place the thermostat on the valve (Fig. 120).

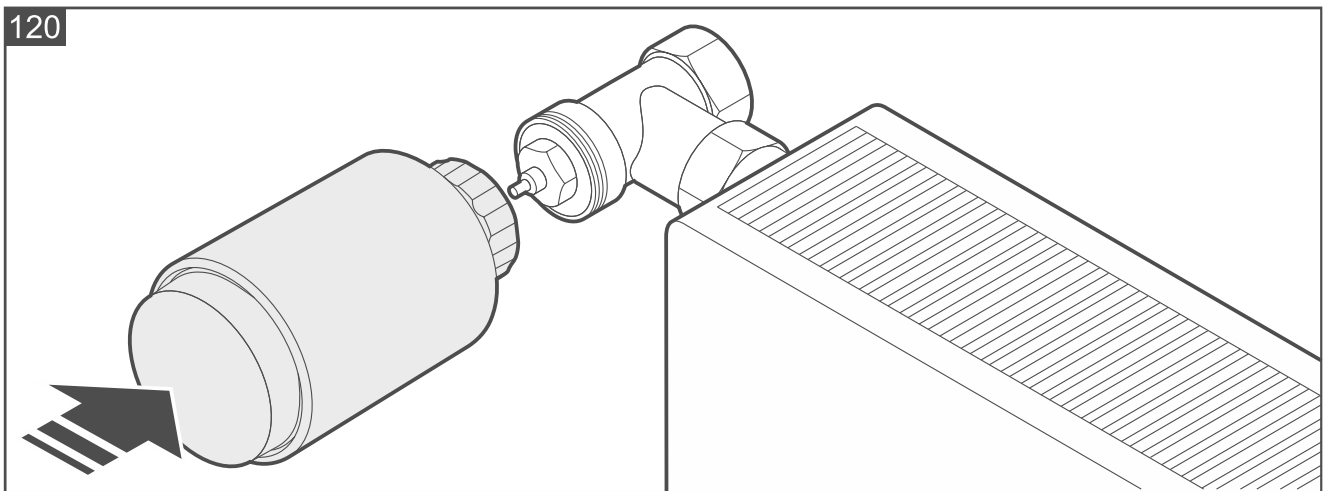

2. Tighten the thermostat on the valve (Fig. 121).

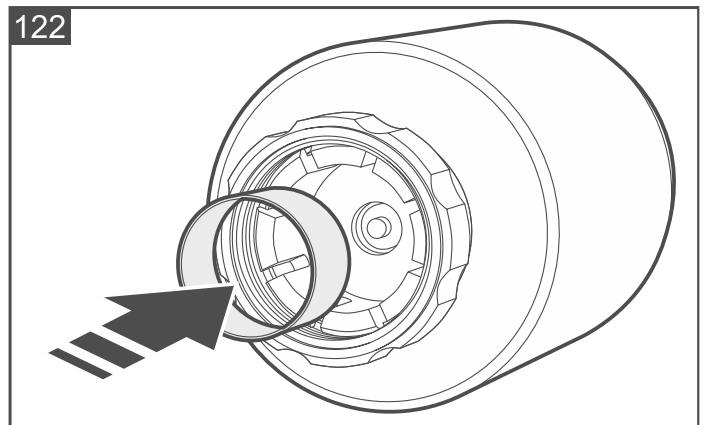
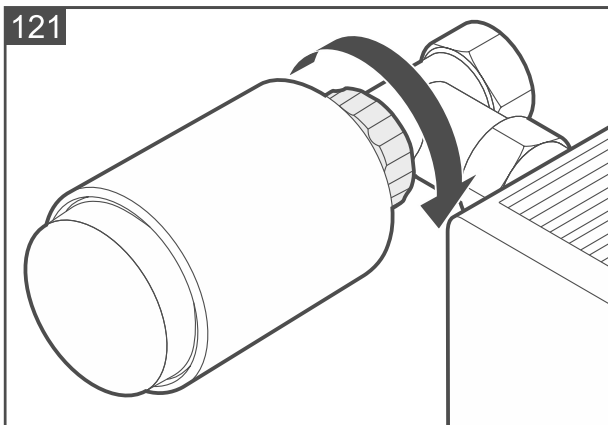

3. If the thermostat is seated loosely on the valve, use the reducer ring. Unscrew the thermostat, place the reducer ring inside its flange (Fig. 122), then repeat points 1 and 2.

### **Mounting on Danfoss RA valve**

1. Fasten the adapter on the valve.
  - 1.1. Place the adapter on the valve (Fig. 123).
  - 1.2. Bend open the adapter clamp with a screwdriver and press the adapter against the valve flange (Fig. 124). Make sure the bumps inside the adapter line up with the notches on the valve body.
  - 1.3. Secure the adapter clamp with a screw (Fig. 125).

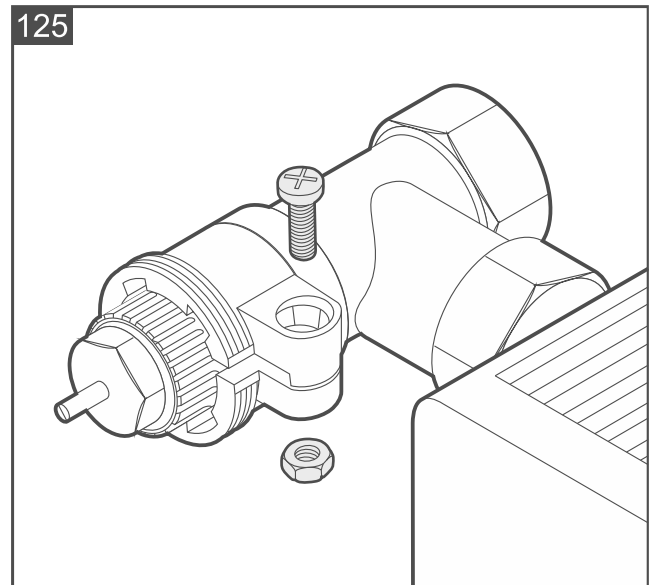
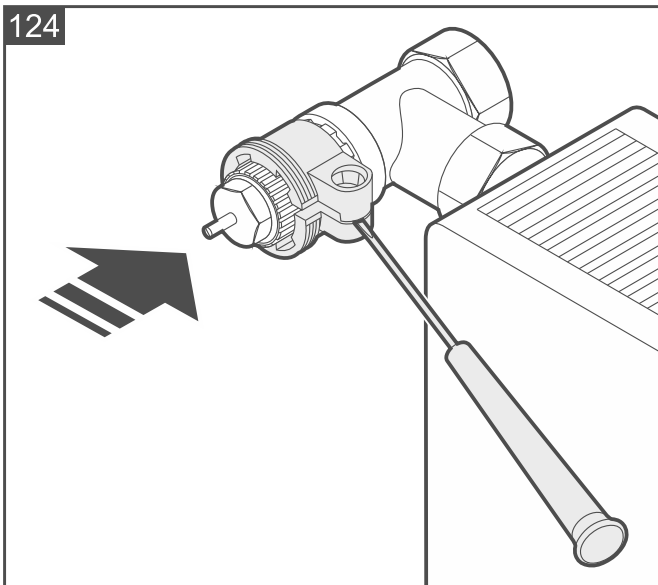
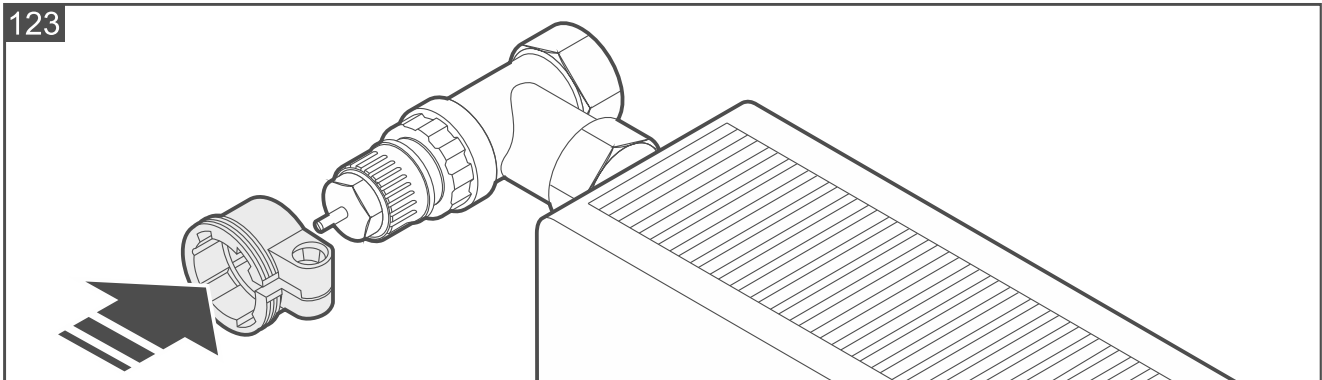

2. Place the thermostat on the valve (Fig. 126).

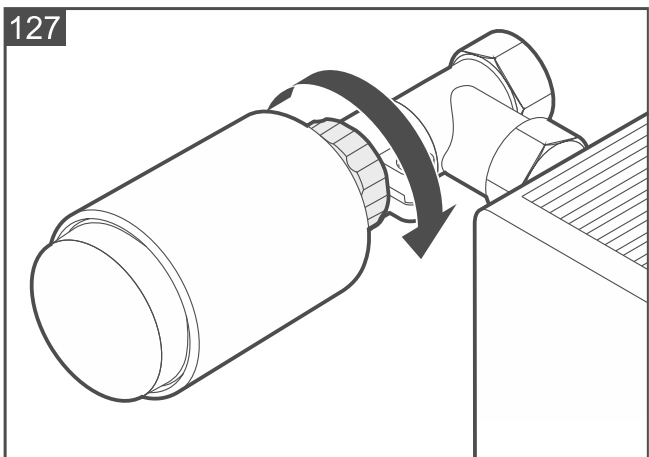
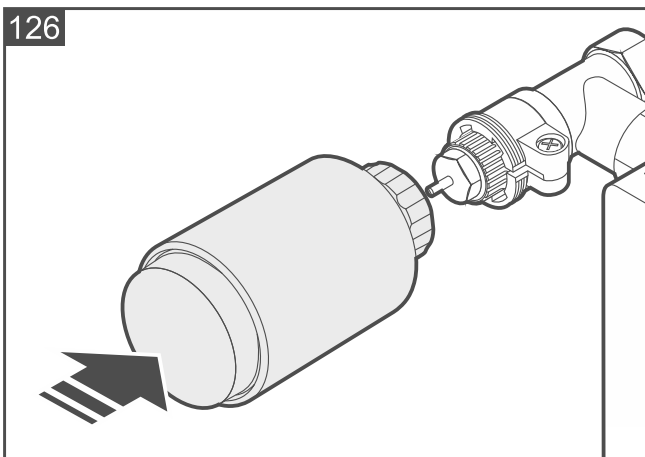

3. Tighten the thermostat on the adapter (Fig. 127).
4. If the thermostat is seated loosely on the valve, use the reducer ring. Unscrew the thermostat, place the reducer ring inside its flange (Fig. 122), then repeat points 2 and 3.

### **Mounting on Danfoss RAV valve**

1. Place the cap on the valve pin (Fig. 128).

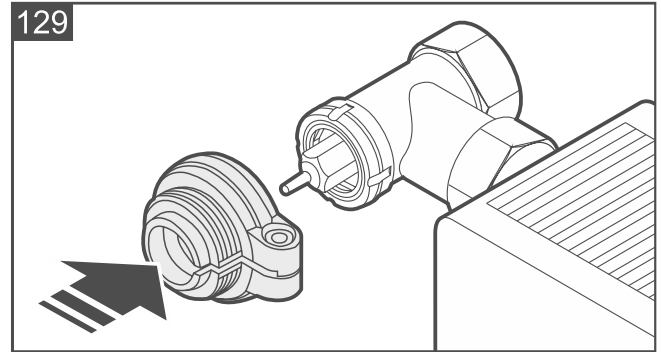
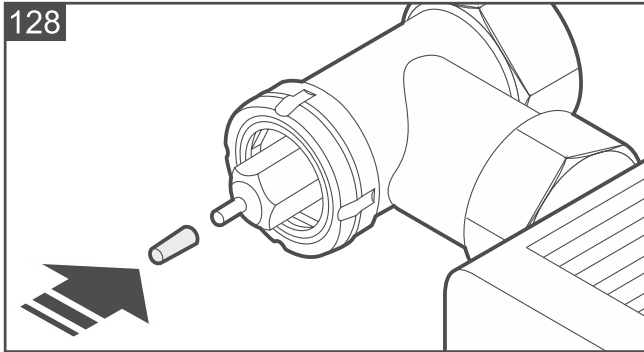

2. Fasten the adapter on the valve.
  - 2.1. Place the adapter on the valve (Fig. 129).
  - 2.2. Bend open the adapter clamp with a screwdriver and press the adapter against the valve flange face (Fig. 130).
  - 2.3. Secure the adapter clamp with a screw (Fig. 131).

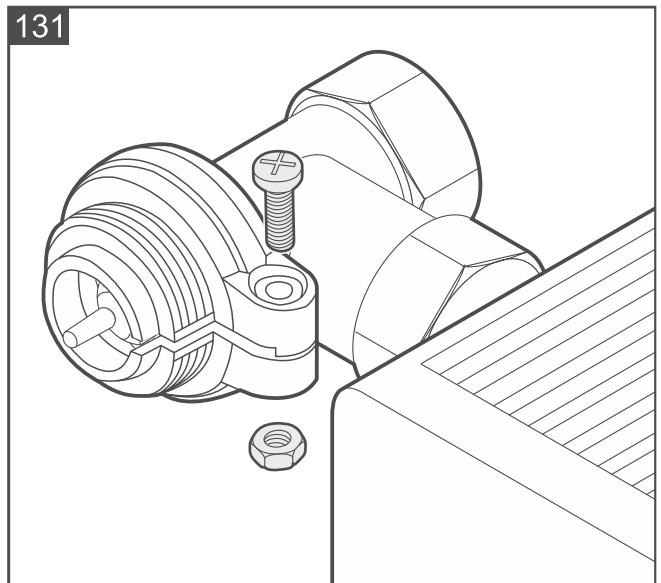
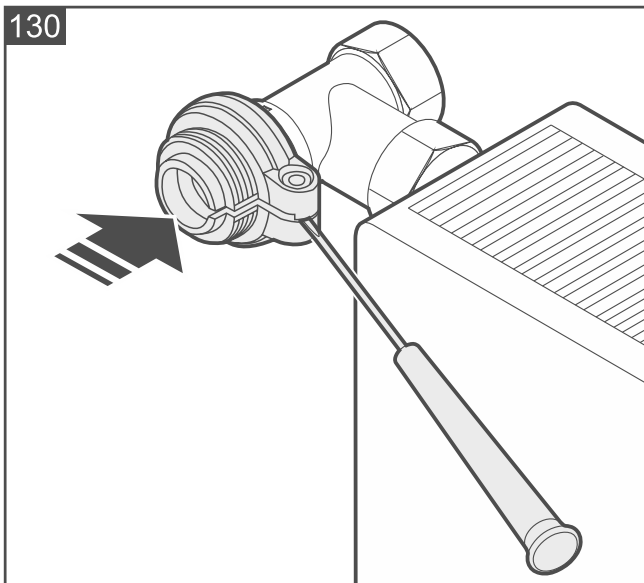

3. Place the thermostat on the valve (Fig. 132).

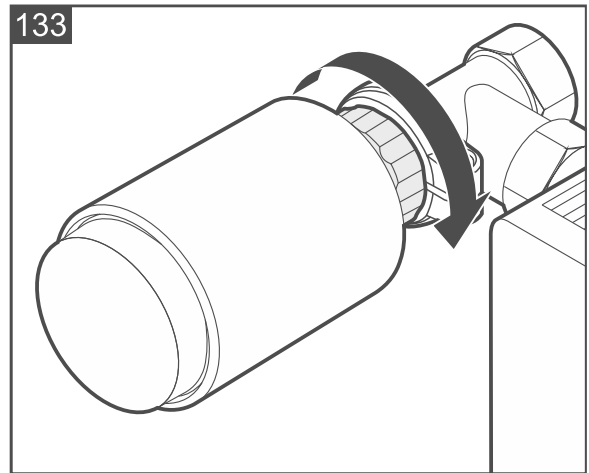
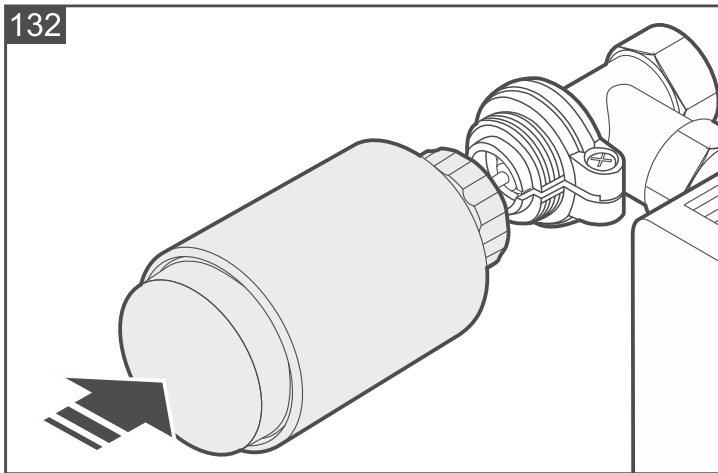

4. Tighten the thermostat on the adapter (Fig. 133).
5. If the thermostat is seated loosely on the valve, use the reducer ring. Unscrew the thermostat, place the reducer ring inside its flange (Fig. 122), then repeat points 3 and 4.

### **Mounting on Danfoss RAVL valve**

1. Mount the adapter on the valve. Press it against the valve flange face (Fig. 134).

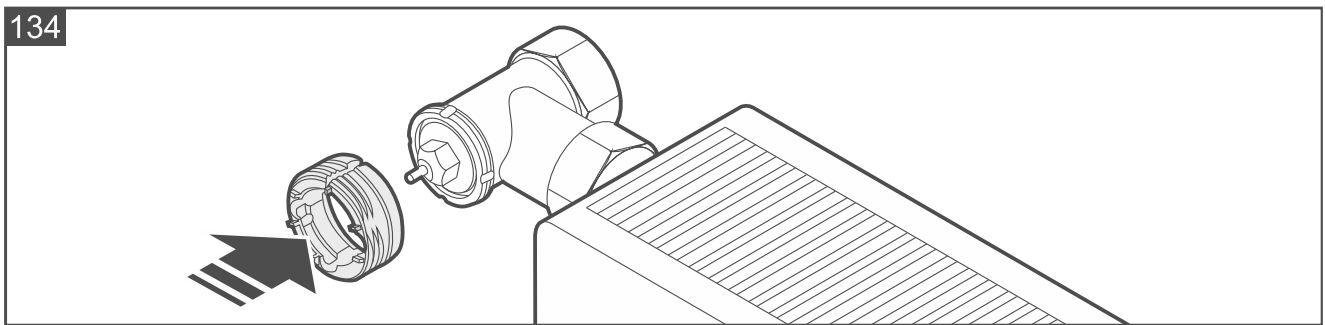

2. Place the thermostat on the valve (Fig. 135).

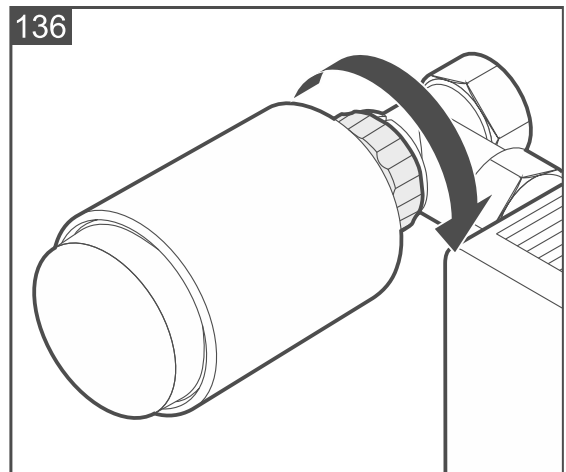
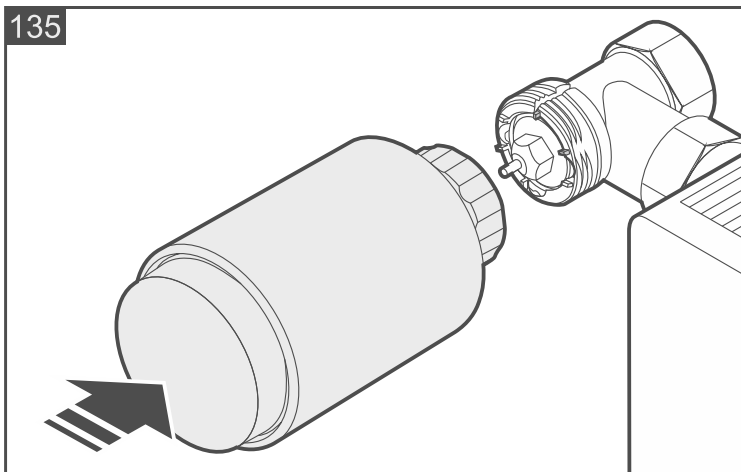

3. Tighten the thermostat on the adapter (Fig. 136).
4. If the thermostat is seated loosely on the valve, use the reducer ring. Unscrew the thermostat, place the reducer ring inside its flange (Fig. 122), then repeat points 2 and 3.

### **4.5.23 Installing the Smart Plug**



**Do not use the plug at locations above 2000 m above sea level.**

### Installation tips for the Smart Plug

- The plug should be installed indoors, in spaces with normal air humidity.
- Do not install the plug outdoors.
- You can connect a 230 VAC appliance up to 2300 W to the socket (do not use the plug to control appliances whose current consumption is greater than 10 A).



*For loads other than resistive, it should not exceed 3 A at 230 VAC. The power factor (cosφ) must be equal to or greater than 0.4.*

### Initiating the Smart Plug

Start the Be Wave app and add the plug to the system. When a request to turn on the device will be displayed, connect the plug to the 230 VAC outlet.

### 4.5.24 Installing the Smart 2-CH Relay



**The device should be installed by qualified personnel.**

**Disconnect power before making any electrical connections.**

**Connect the controller to a single-phase network according to the applicable standards.**

**Do not remove the controller from the enclosure. Installing the controller without enclosure or with a damaged enclosure poses a risk of electric shock and may damage the device.**

**Do not install the controller at locations above 2000 m above sea level.**

### Description of the Smart 2-CH Relay



*The variant A of the device (with screw terminals) had been manufactured until 2024 when it was replaced by variant B (no terminals, wires only).*

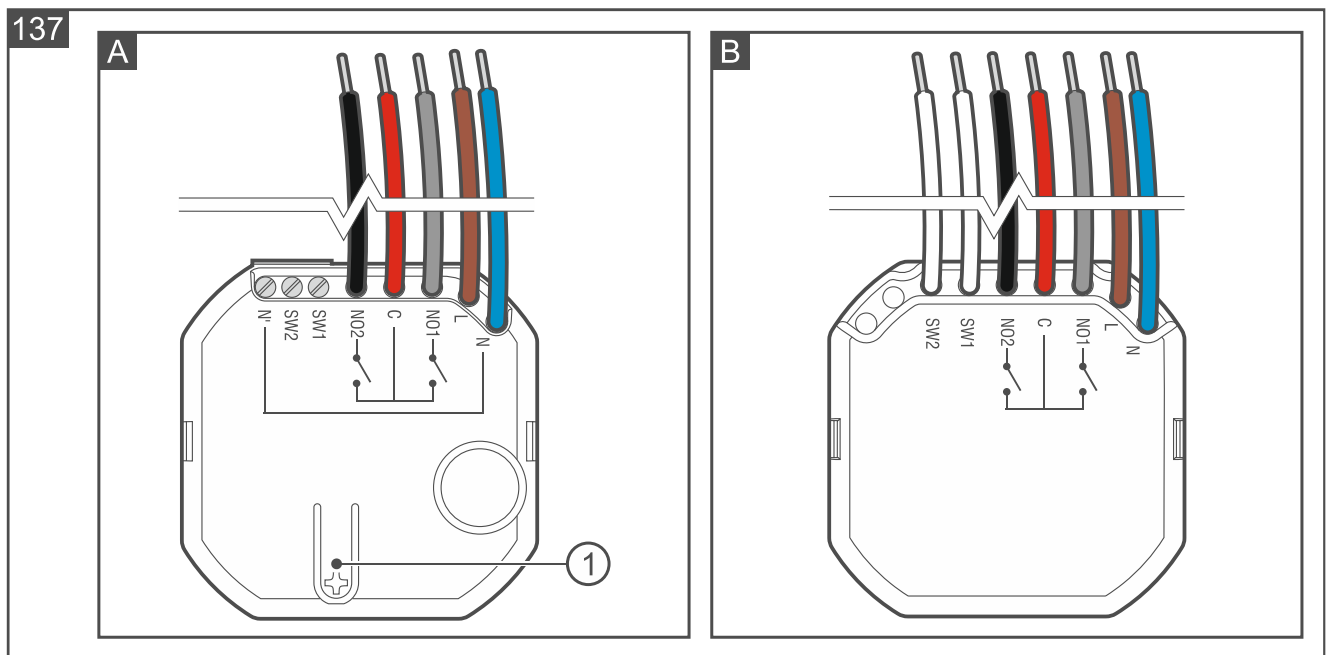

① button used to:

- register the controller in the system – press while adding the controller to the system,

- block / unblock the registration – press and hold for 10 seconds to block / unblock the capability to add the controller to the system.



*In variant B, the button is located at the back of the enclosure.*

### **Wires**

- N** [blue] - for connecting 230 VAC supply neutral wire.
- L** [brown] - for connecting 230 VAC supply phase wire.
- NO1** [gray] - NO contact of the relay output 1 (normally it is disconnected from the common contact C – does not conduct electricity).
- NO2** [black] - NO contact of the relay output 2 (normally it is disconnected from the common contact C – does not conduct electricity).
- C** [red] - common contact C of the relay outputs.
- SW1** [white] - control input 1. [only variant B]
- SW2** [white] - control input 2. [only variant B]

### **Terminals [only variant A]**

- SW1** - control input 1.
- SW2** - control input 2.
- N'** - for connecting 230 VAC supply neutral wire.



*Given the specific character of radio communication, it is not recommended that the controller be used in applications where quick switching of the output status is required.*

*Using the relay outputs for frequent (more than once every 10 seconds) switching of capacitive loads, e.g. LED lighting power supplies, LED lamps, etc. is not recommended.*

*Do not connect more than one LED lighting power supply to the relay output.*

*The controller inputs are not galvanically isolated.*

### **Installation tips for the Smart 2-CH Relay**

- The controller should be installed indoors, in spaces with normal air humidity.
- Do not install the controller outdoors.
- The electrical circuit to which the controller is to be connected must have suitable protection. Instruct the owner / user of the system on how to disconnect the controller from the mains supply (e.g. indicate the fuse or circuit breaker protecting the controller supply circuit).
- Install the controller in an electrical junction box (a deep junction box with a diameter of at least 60 mm).
- To connect the wires, use screw terminal blocks, splicing connectors, etc.
- To the relay output you can connect a 230 VAC appliance with power consumption up to 5 A.
- To the control input you can connect a push-button or a switch designed for 230 V electrical installations.
- To connect the push-button / switch, use flexible wires with a cross-section of 0.5-0.75 mm<sup>2</sup>.

## Mounting the Smart 2-CH Relay

1. Power off the circuit to which the controller is to be connected.
2. Open the electrical junction box in which the controller is to be installed.
3. Connect the controller to the 230 VAC supply circuit (Fig. 138):
  - brown wire [L] to phase wire.
  - blue wire [N] to neutral wire.
4. Connect the wires of controller relay outputs to the wires of electrical circuits to be controlled by the controller (Fig. 138).
5. Connect the push-buttons / switches to the controller inputs (Fig. 138).
6. Place the controller in the junction box. Make sure the electrical wires are behind the controller enclosure.
7. Power on the circuit to which the controller is connected.
8. Start the Be Wave app and add the controller to the system. When a request to turn on the device will be displayed, press the button marked with the + symbol on the enclosure (Fig. 137).
9. Close the junction box.

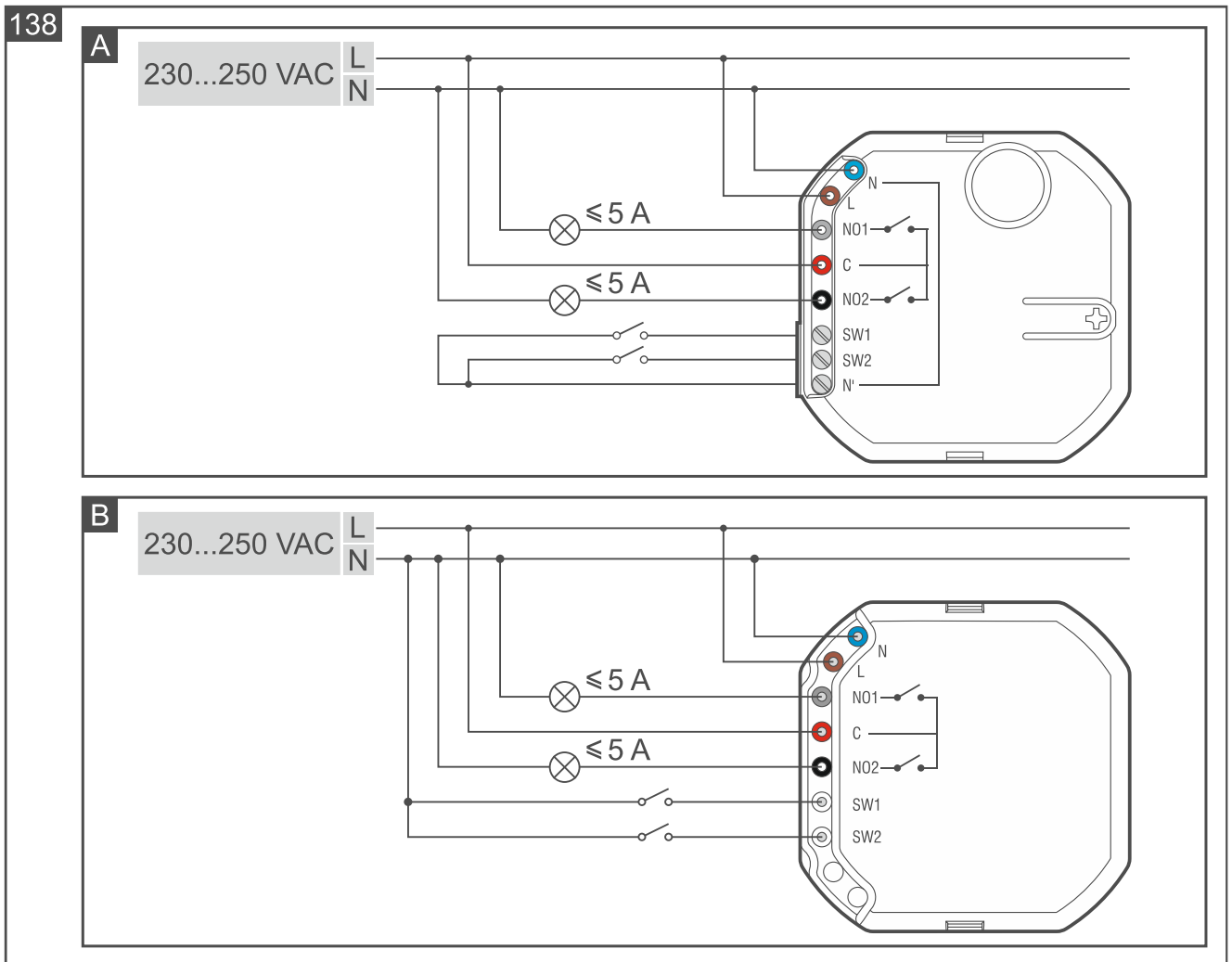

## 4.5.25 Installing the Smart Switch Controller

### Description of the Smart Switch Controller

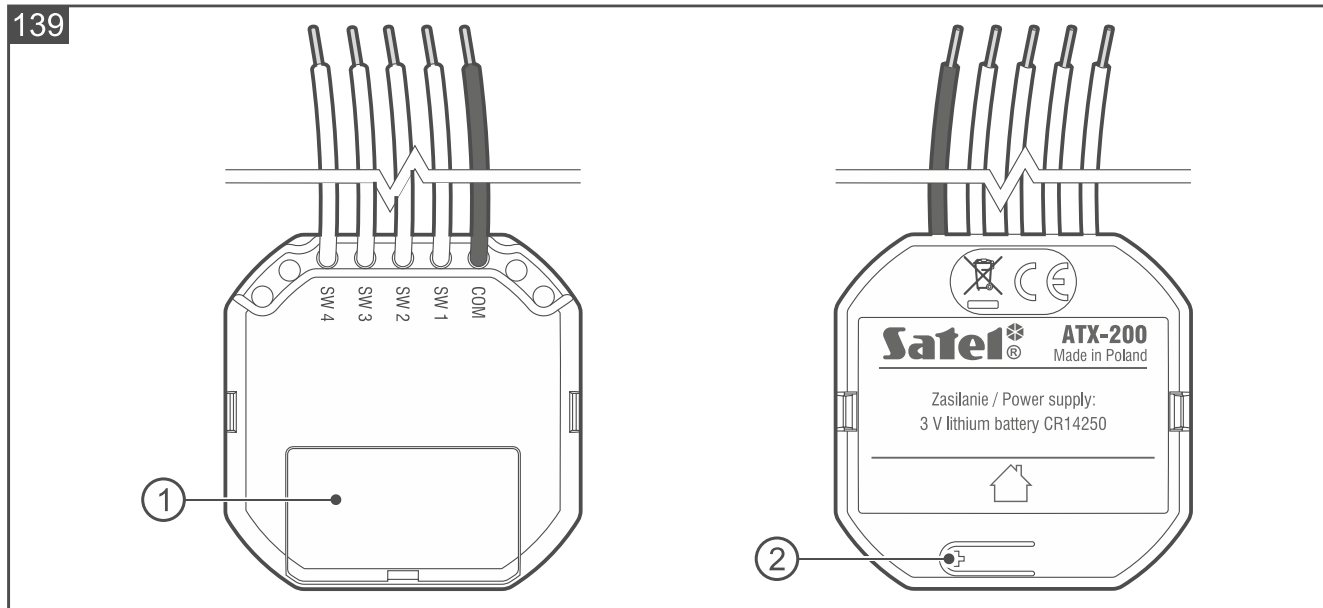

① battery holder cover (CR14250 3 V). Use a screwdriver to remove the cover (Fig. 139).

② button used to:

- register the module in the system – press while adding the module to the system,
- block / unblock the registration – press and hold for 10 seconds to block / unblock the capability to add the module to the system.

#### Wires

- COM** [black] - common ground.  
**SW1** [white] - control input 1.  
**SW2** [white] - control input 2.  
**SW3** [white] - control input 3.  
**SW4** [white] - control input 4.

#### Installation tips for the Smart Switch Controller

- The module should be installed indoors, in spaces with normal air humidity.
- Do not install the module outdoors.
- Install the module in an electrical junction box (a deep junction box with a diameter of at least 60 mm).
- To connect the wires, use screw terminal blocks, splicing connectors, etc.
- You can connect a push-button or a switch to the controller inputs. The push-button is the preferred choice. It provides more functionality.

#### Mounting the Smart Switch Controller

1. Install the battery in the module (Fig. 140).
2. Open the electrical junction box in which the module is to be installed.
3. Connect the push-buttons / switches to the module inputs (Fig. 141).
4. Start the Be Wave app and add the module to the system. When a request to turn on the device will be displayed, press the button marked with the + symbol on the enclosure (Fig. 139).

5. Place the module in the junction box. Make sure the wires are behind the module enclosure.
6. Close the junction box.

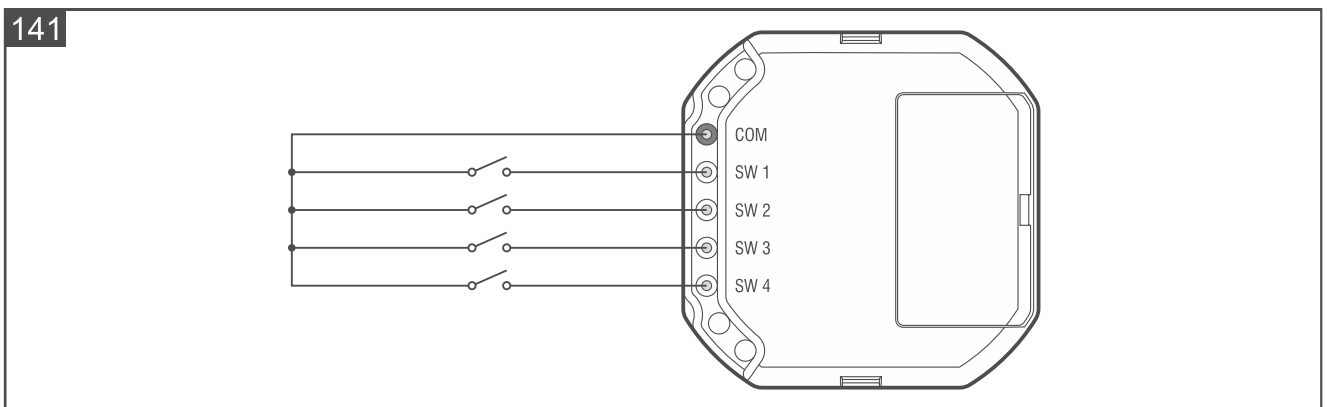
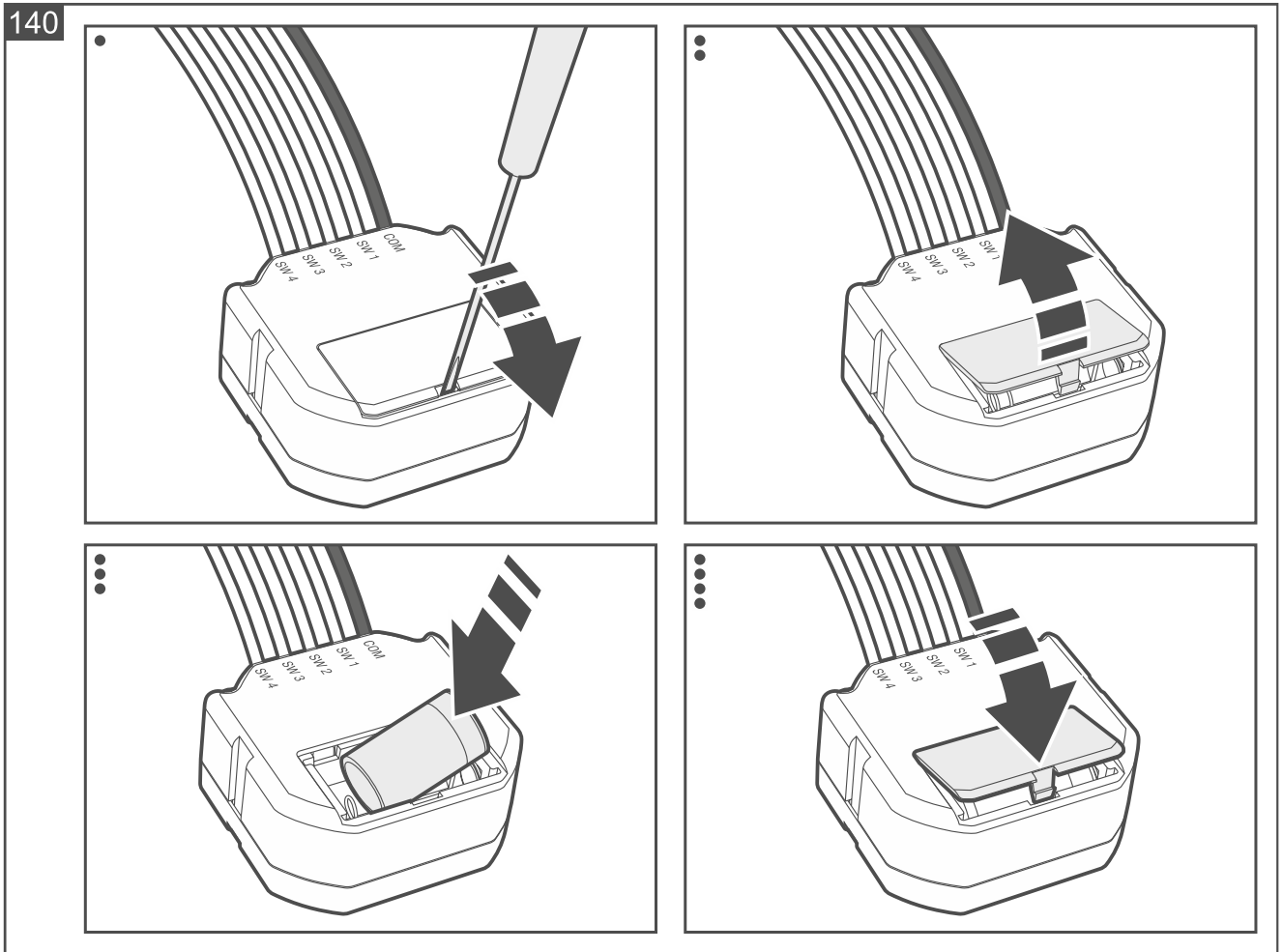

#### 4.5.26 Installing the Smart Button

##### Installation tips for the Smart Button

- The button should be installed indoors, in spaces with normal air humidity.
- Do not install the button outdoors.

## Mounting the Smart Button

1. Open the button enclosure (Fig. 142).

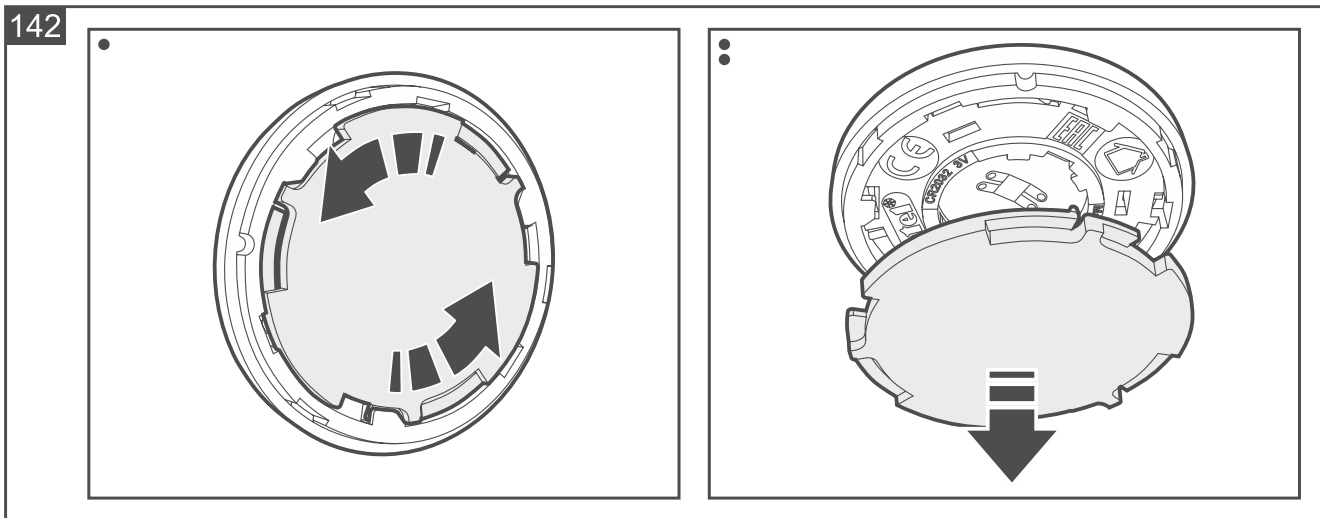

2. Stick the double-sided mounting tape to the enclosure base.
3. Stick the enclosure base to the surface.
4. Start the Be Wave app and add the button to the system. When a request to turn on the device will be displayed, install the battery in the button.
5. Close the button enclosure.

### 4.5.27 Installing the Smart Repeater



**The device should be installed by qualified personnel.**

**Disconnect power before making any electrical connections.**

**Connect the repeater to a single-phase network according to the applicable standards.**

**Do not install the repeater at locations above 2000 m above sea level.**



*Only one Smart Repeater can be installed in the system.*

## Description of the Smart Repeater

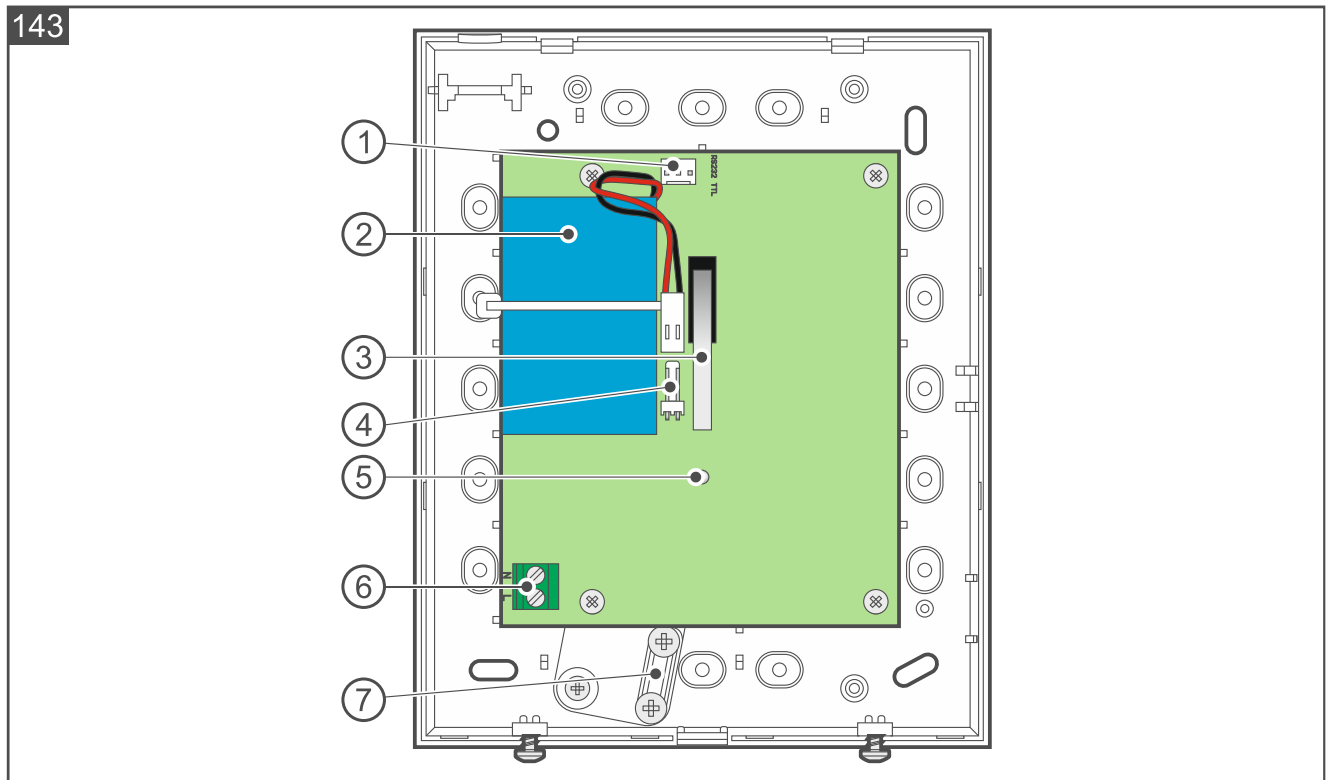

The figure shows the inside of the repeater after removing the cover.

- ① RS-232 (TTL) port – unused.
- ② rechargeable battery.
- ③ tamper switch.
- ④ battery connector.
- ⑤ LED indicator:  
ON in green – normal operation,  
flashing in green – no 230 VAC power,  
single red flash – communication with the controller.
- ⑥ 230 VAC terminals.  
N - for connecting neutral wire.  
L - for connecting phase wire.
- ⑦ element fastening the power cable.

### Installation tips for the Smart Repeater

- The repeater should be installed indoors, in spaces with normal air humidity.
- Do not install the repeater outdoors.
- Prior to installation you should plan the arrangement of the wireless devices whose signals are to be retransmitted. Select the place of installation so that the repeater is located within the operating range of the devices.
- It is recommended that the repeater be mounted high above the floor. This will allow you to get a better range of radio communication and eliminate the risk of the repeater being covered by people moving around the premises.
- The radio communication range depends not only on the installation location, but also on the position of the repeater antenna, i.e. on how the enclosure is mounted (horizontally,

vertically, diagonally). Before you install the repeater, check in which position the range of the repeater is the best.

- The repeater should be permanently connected to the 230 VAC mains supply.
- The electrical circuit to which the repeater is to be connected must have suitable protection (2-pole switch disconnecter and/or 16 A slow-blow fuse).
- Instruct the owner / user of the system on how to disconnect the repeater from the mains supply (e.g. indicate the fuse or circuit breaker protecting the repeater supply circuit).

## Mounting the Smart Repeater

1. Loosen the cover locking screws and remove the enclosure cover (Fig. 144).

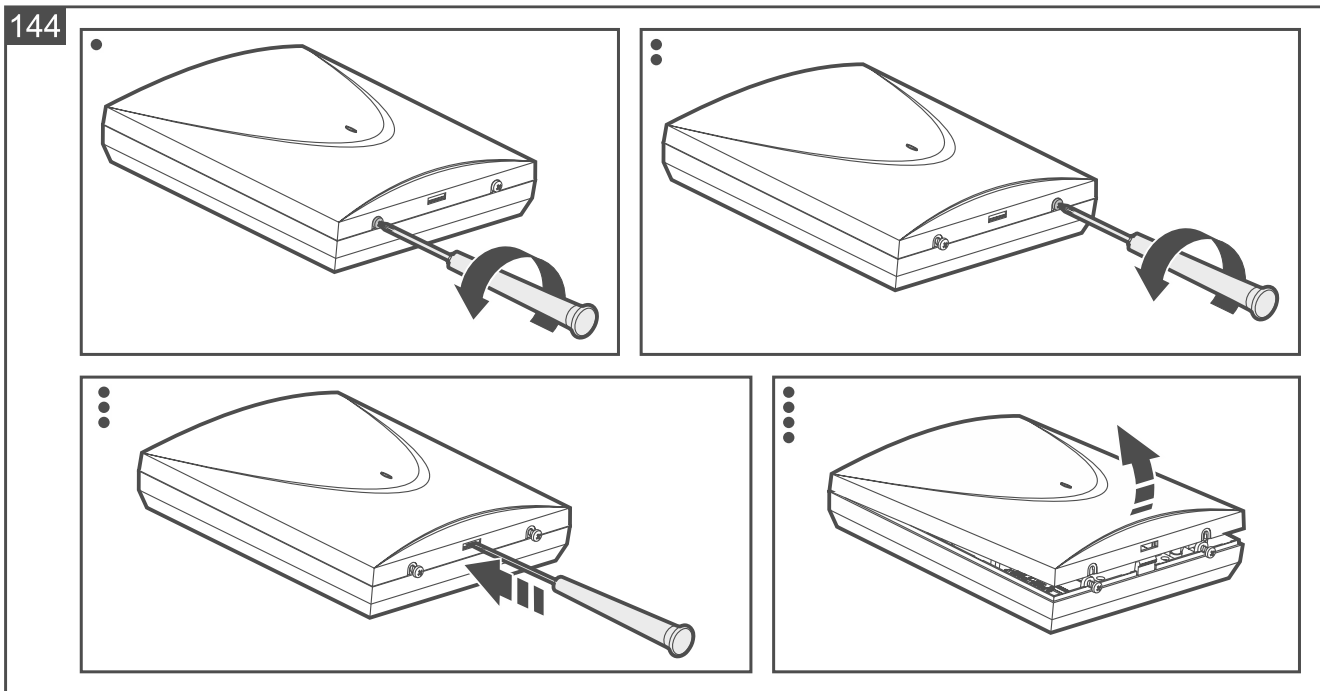

2. Make an opening for the power cable in the enclosure base (Fig. 145).

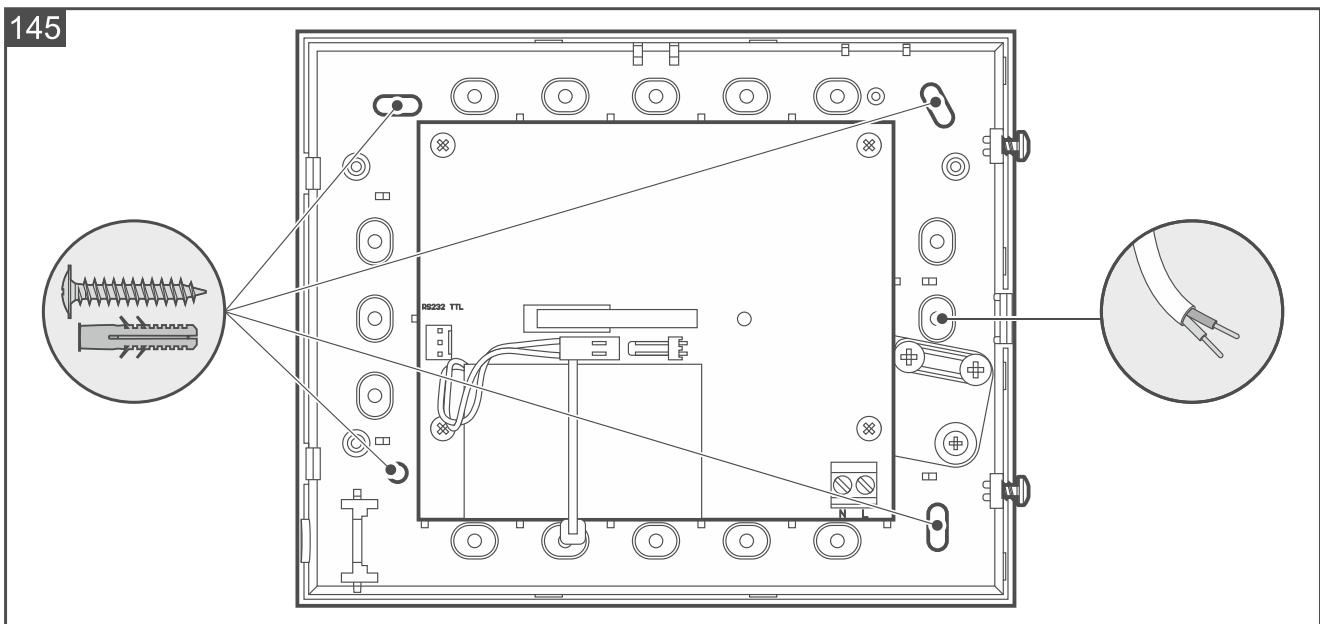

3. Place the enclosure base against the wall and mark location of the mounting holes (Fig. 145).

4. Drill the holes in the wall for wall plugs (anchors). Use wall plugs specifically intended for the mounting surface (different for concrete or brick wall, different for plaster wall, etc.).
5. Run the 230 VAC power cable through the opening in the enclosure base.
6. Secure the enclosure base to the wall with screws.
7. Unscrew the element fastening the power cable (Fig. 146).

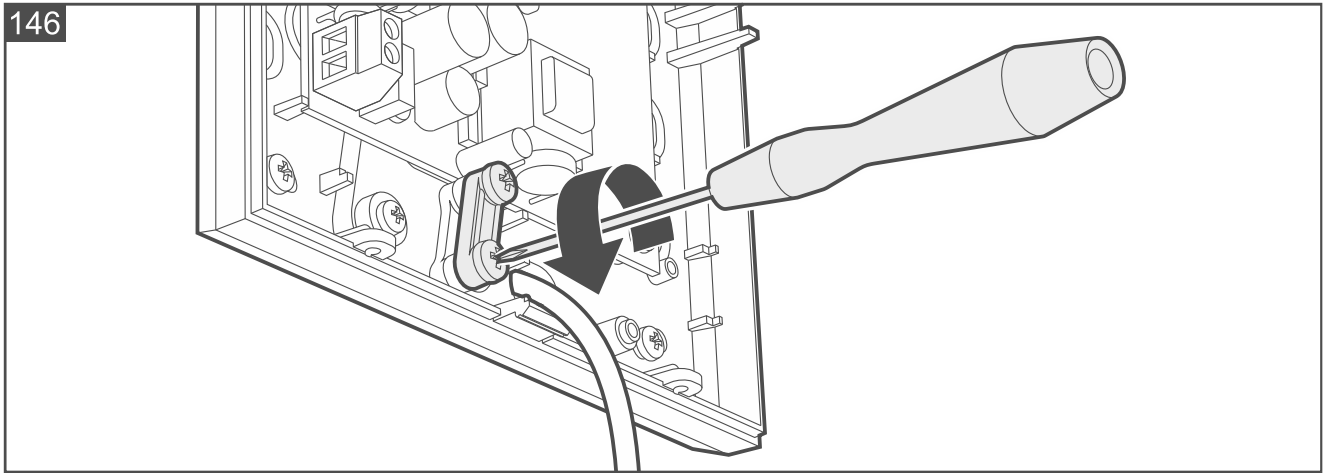

8. Screw the 230 VAC power wires to terminals: phase wire to L terminal, neutral wire to N terminal (Fig. 147).

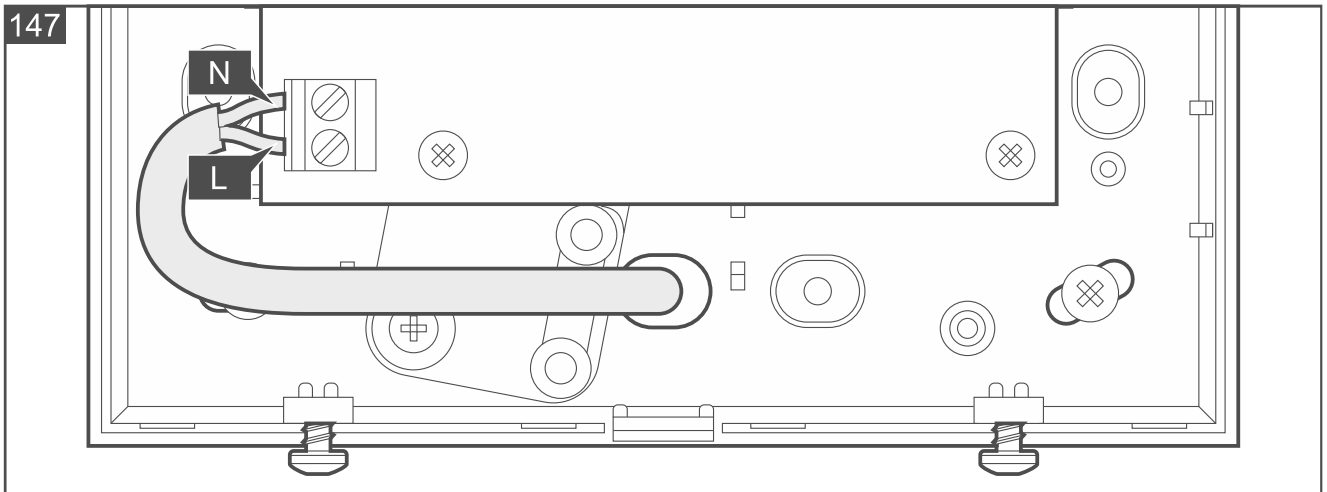

9. Screw the element fastening the power cable (Fig. 148).



10. Connect the battery to the connector (Fig. 149). The repeater will start up.

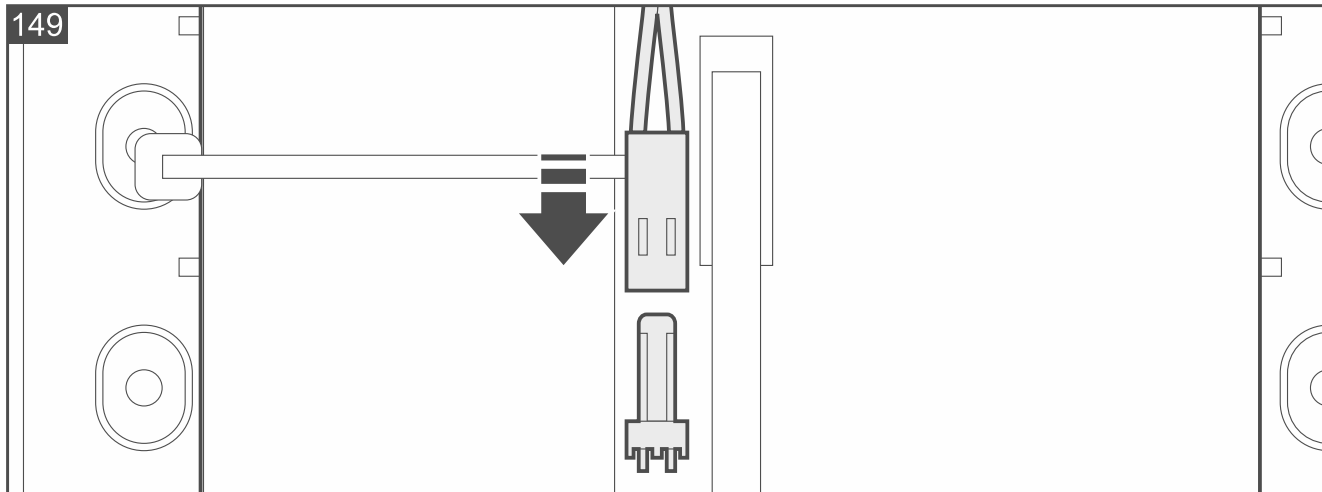

11. Replace the cover and lock it with a screw.

12. Power on the circuit to which the repeater is connected.

## 4.6 Adding the Smart Keyfob to the system

Start the Be Wave app and add the Smart Keyfob to the system. When a request to turn on the device will be displayed, press any button on the keyfob.



*If you want to add a keyfob that was previously used in another system, you need to restart it first:*

*APT-210: press and hold the ^ and v buttons for 10 seconds,*

*APT-200: press and hold the ○ and ● buttons for 10 seconds,*

*APT-200 / APT-210: remove the battery for 10 seconds.*

## 5. Testing

It is a good practice to test the devices after they are added to the system. We also recommend to periodically check if the devices work correctly. The diagnostic mode is available in the Be Wave app for the purpose of testing and maintenance (battery replacement, cleaning the smoke chamber of the Fire Detector Plus / Fire Detector Pro, etc.). When the diagnostic mode is enabled:

- detector LED indicators are ON (the indicators are normally OFF) – e.g. you can check if motion detectors detect motion,
- the Outdoor Motion Detector and the Outdoor Dusk Detector react quicker to changes in light intensity – you can cover the detector with a cardboard box, a thick, dark fabric, etc. The detector should detect dusk after 3 seconds,
- the Glass Break Detector reacts to the sound of breaking glass alone (high-frequency sound),
- tamper signaling in the sirens is blocked – you can open the siren enclosure without starting the signaling.



*After the diagnostic test is enabled, automatic calibration of the microwave sensor is carried out in the Motion Detector Plus, Outdoor Motion Detector and Outdoor Curtain Detector. For 10 seconds after the diagnostic mode is enabled, there should be no moving object in the detection area of the microwave sensor, as this will prevent proper calibration of the sensor.*

## 5.1 Enabling the diagnostic mode

---

1. Tap the  icon.
2. Tap *Diagnostics > Enable diagnostic mode*.



*All devices will enter the diagnostic mode after some time (up to 24 seconds).*

*According to requirements of the EN 50131 standard, the level of radio signals sent by wireless devices is reduced when the diagnostic mode is enabled.*

*Remember to disable the diagnostic mode when testing and maintenance of the BE WAVE devices is complete.*

## 6. Maintenance

---

### 6.1 Firmware update

---

1. Tap the  icon.
2. Tap *Smart HUB configuration > Update the system*.
3. Tap Yes to update firmware for the controller and the BE WAVE devices.



*The Update the system button is available when new firmware version is available.*

*When the firmware update is complete, the controller will be restarted.*

*Sending out the update file to the BE WAVE device may take some time. The update itself takes only several seconds. The device does not execute its normal functions then.*

### 6.2 Replacing the (rechargeable) battery

---



**Be particularly careful when replacing the battery. The manufacturer is not liable for the consequences of incorrect installation of the battery.**

**The used batteries must not be discarded, but should be disposed of in accordance with the existing rules for environment protection.**

**The Smart HUB Plus / Smart HUB / Smart HUB Plus LV rechargeable battery will not be charged in temperatures below 0°C.**

#### 6.2.1 Replacing the rechargeable battery in the Smart HUB Plus / Smart HUB / Smart HUB Plus LV controller



**The rechargeable battery in the controller should be replaced by qualified personnel.**

The Be Wave app will notify you that the rechargeable battery is low. The battery should then be replaced as soon as possible.



*The figures show how to replace the battery in the Smart HUB Plus / Smart HUB controller.*

1. Enable the diagnostic mode in the Be Wave app.

2. Open the controller enclosure.
3. Remove the old battery (Fig. 150).
4. Install the new battery (Fig. 151).
5. Close the enclosure and secure it with screws.
6. Disable the diagnostic mode in the Be Wave app.

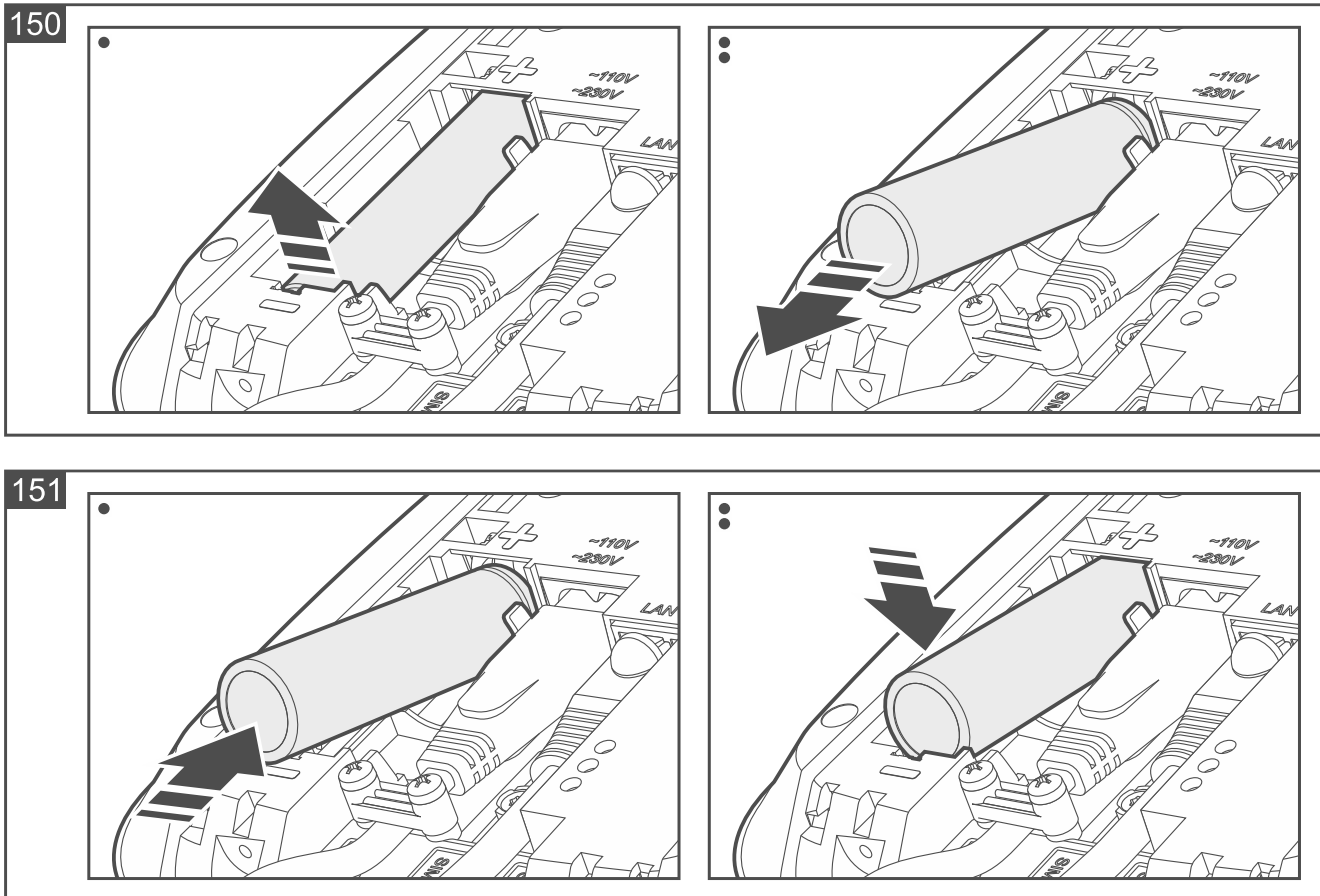

### 6.2.2 Replacing the battery in the BE WAVE device

The Be Wave app will indicate that the battery in the BE WAVE device is low. The battery should then be replaced as soon as possible.

The Fire Detector Plus, Fire Detector Pro and Carbon Monoxide Detector additionally produce a series of 3 LED flashes and 3 beeps every 30 seconds to indicate low battery.

1. On the Be Wave home screen tap the room in which the low battery device is installed.
2. Tap the name of the low battery device.
3. Tap *Battery replacement*.
4. Open the device enclosure.
5. Remove the low battery.
6. Install the new battery.
7. Close the device enclosure.
8. Tap *Unbypass device* in the Be Wave app.

### Replacing the battery in the Outdoor Siren



The new battery must be installed as described below to run the battery initialization procedure. The required power supply parameters are only possible with the properly initialized battery.

1. On the Be Wave home screen tap the room in which the low battery siren is installed.

2. Tap the name of the low battery siren.
3. Tap *Battery replacement*.
4. After the leftmost LED on the siren starts flashing every 3 seconds, you can open the siren enclosure.
5. Remove the low battery.
6. Press and hold down the tamper switch.
7. Install the new battery.
8. When the leftmost LED on the siren starts flashing every second, release the tamper switch. The flashing LED indicates that the battery is being initialized. As long as the LED keeps flashing, the siren is not ready for normal work.
9. Start the “Unbypass device” function in the Be Wave app.

### Opening the Smart Keyfob enclosure

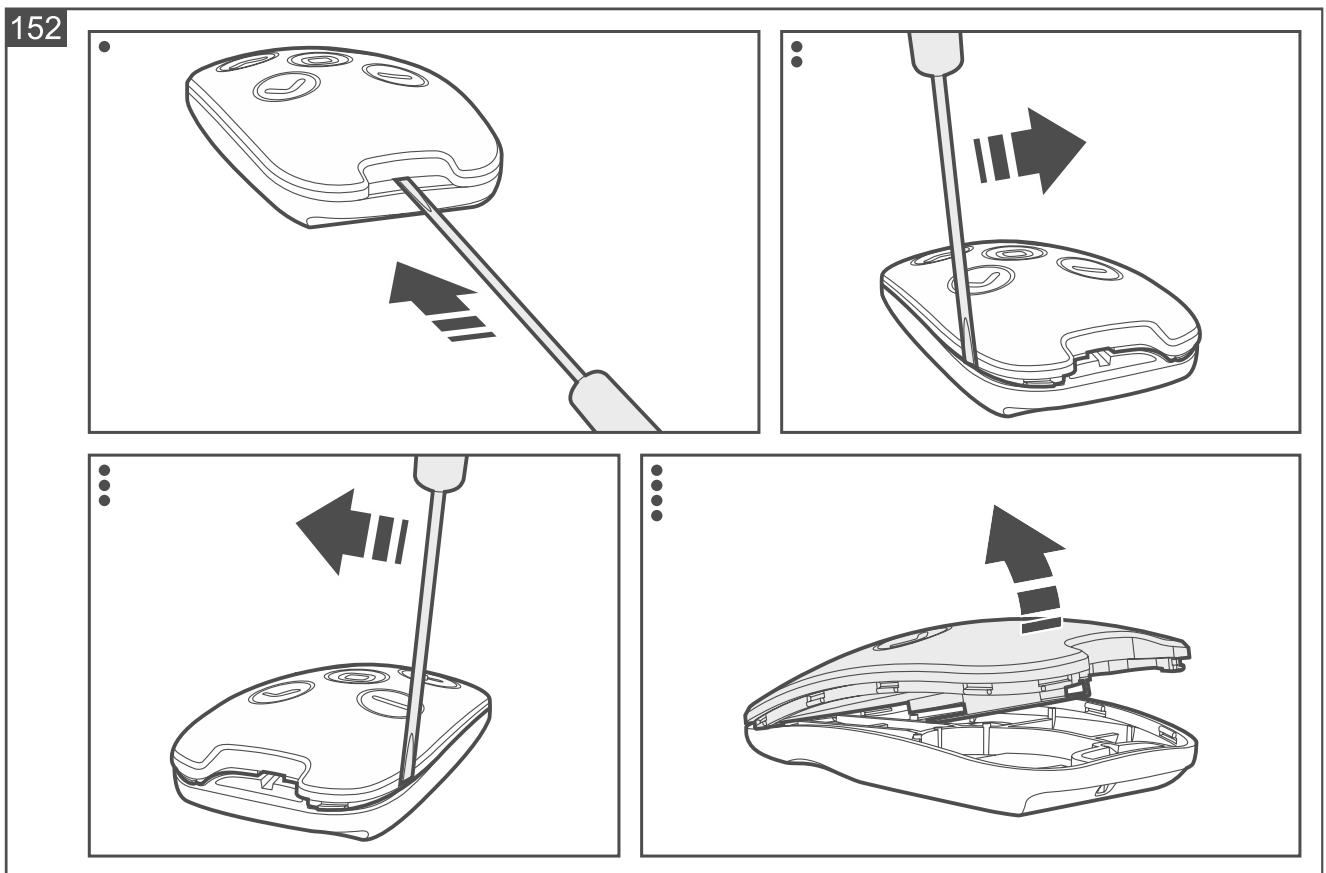

### 6.3 Cleaning the Fire Detector Plus / Fire Detector Pro smoke chamber



*The Be Wave app will notify you that the smoke chamber needs to be cleaned.*

*The figures show the Fire Detector Plus.*

1. Enable the diagnostic mode in the Be Wave app.
2. Remove the cover locking screw and open the detector enclosure.
3. Remove the battery.
4. Pull the release lever (Fig. 153) to unlock the electronics module and turn it counter-clockwise (Fig. 154).
5. Remove the electronics module with the smoke chamber (Fig. 155).

6. For the Fire Detector Plus, remove the plastic element with the thermistor from the smoke chamber cover (Fig. 156).
7. Release the mounting catch (Fig. 157) and remove the smoke chamber cover (Fig. 158).

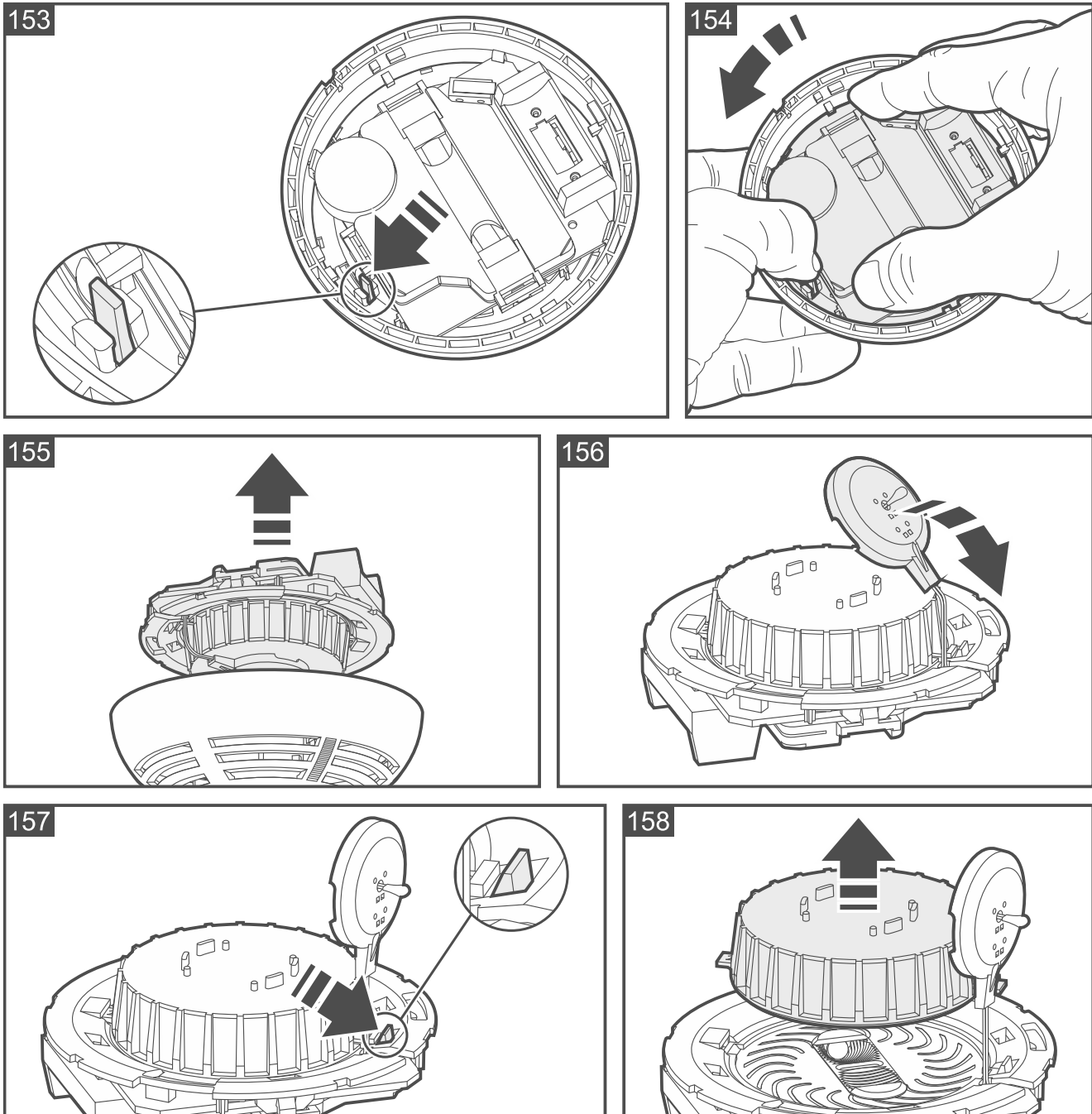

8. Using a soft brush or compressed air, clean the labyrinth in the cover, as well as the base of the smoke chamber. Pay attention to the recesses where LEDs are installed.
9. Replace the smoke chamber cover.
10. For the Fire Detector Plus, replace the plastic element with the thermistor on the smoke chamber.
11. Secure the electronics module with the smoke chamber in the cover and turn it clockwise.
12. Install the battery.
13. Replace the detector cover and lock it with a screw.
14. Press the test / reset button. A fire alarm should be generated soon after. The alarm will be signaled by the detector (continuous sound, LED indicator ON). You will receive a notification from the Be Wave app.

15. Press again the test / reset button to clear the alarm.
16. Disable the diagnostic mode in the Be Wave app.

## **6.4 Restoring the controller factory settings**

---

### **6.4.1 Restoring the factory settings from the Be Wave app**

1. Tap the  icon.
2. Tap *Smart HUB configuration* > *Restore factory settings*.
3. Tap Yes to restore the factory settings.

### **6.4.2 Hardware factory restore**

1. Enable the diagnostic mode in the Be Wave app.
2. Open the controller enclosure.
3. Insert a pin in hole marked ⑥ (Fig. 2) and hold for 5 seconds.

## **6.5 Turning off the Smart HUB Plus / Smart HUB controller**

---

1. Disconnect the power cable from the power outlet.
2. Remove the cover locking screws.
3. Open the controller enclosure.
4. Remove the battery.

## **6.6 Turning off the Smart HUB Plus LV controller**

---

1. Turn off the controller DC power.
2. Remove the cover locking screws.
3. Open the controller enclosure.
4. Remove the battery.

## 7. Using the Smart Keypad

159

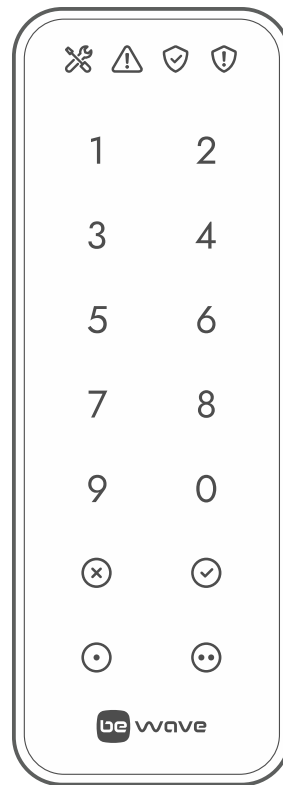

### 7.1 LED indicators

LED	Color	Description
	blue	<b>ON</b> – diagnostic mode is enabled
	yellow	<b>flashing</b> – trouble or trouble memory
	green	<b>ON</b> – system is armed <b>flashing</b> – exit delay countdown
	red	<b>ON</b> – alarm or alarm memory



If the Grade 2 mode is enabled in the system, the LED is OFF.

If the system is armed, the LED is OFF.

## 7.2 Keys

### Functions of keys

1 ... 0	touch to enter a digit (for access code)
⊗	touch to clear the entered code
⊙	enter access code and touch to arm the system / disarm the system / clear alarm
⊙	touch to start action 1 enter access code and touch to start action 2
⊙	touch to start action 3 enter access code and touch to start action 4



*Availability of the actions depends on the keypad settings.*

## 7.3 Sound signaling



*The sound signaling can be disabled.*

### 7.3.1 Beeps generated when keypad is in use

**1 short beep** – key touched.

**4 short beeps** – function started.

**2 long beeps** – function cannot be started (wrong access code or function unavailable) / entered access code cleared.

### 7.3.2 Event signaling

**1 long beep every 3 seconds** – exit delay countdown – longer than 10 seconds.

**1 short beep every second** – exit delay countdown – shorter than 10 seconds.

**1 very long beep** – end of exit delay.

**2 short beeps every second** – entry delay countdown.

**Continuous beep** – alarm. The signaling goes on for up to 60 seconds.

## 7.4 Operating modes of battery-powered keypad

When the keypad is powered by the batteries, it operates in one of the two modes:

**Wake-up mode** – LED indicators, backlight and sound signaling are enabled. The keypad is woken up:

- after you touch and hold any key for 1 second,
- when exit delay is signaled,
- when entry delay is signaled,
- when alarm is signaled.



*In case of signaling, the keypad is woken up with a delay of several seconds. This is caused by the specific nature of the radio communication in the system.*

*If the ECO mode is enabled for the keypad, it is woken up only after you touch and hold any key for 1 second.*

**Sleep mode** – LED indicators, backlight and sound signaling are disabled. The purpose of this mode is to save battery. The sleep mode is started:

- after 60 seconds since the last key touch,
- when exit delay signaling is over,
- when entry delay signaling is over,
- after 60 seconds of alarm signaling.



*The keypad will not go to sleep if it is powered from a power supply (SATEL APS-055 power supply). The LED indicators, backlight and sound signaling are enabled all the time.*

## 8. Using the Smart Keyfob

160



*Assign actions to the keyfob buttons in the Be Wave app.*

Press a button to start an action. All LED indicators will start flashing. The LEDs will stop flashing when:

- when transmission from the keyfob is received: there will be 2 beeps (3 beeps if the battery is low) and a flash of:
  - green indicator – action started,
  - red indicator – action not started / no action assigned to the button.
- transmission from the keyfob has not been received for several seconds: there will be 1 long beep.

## 9. Manual control of the devices

### 9.1 Manual control of the Smart Thermostat

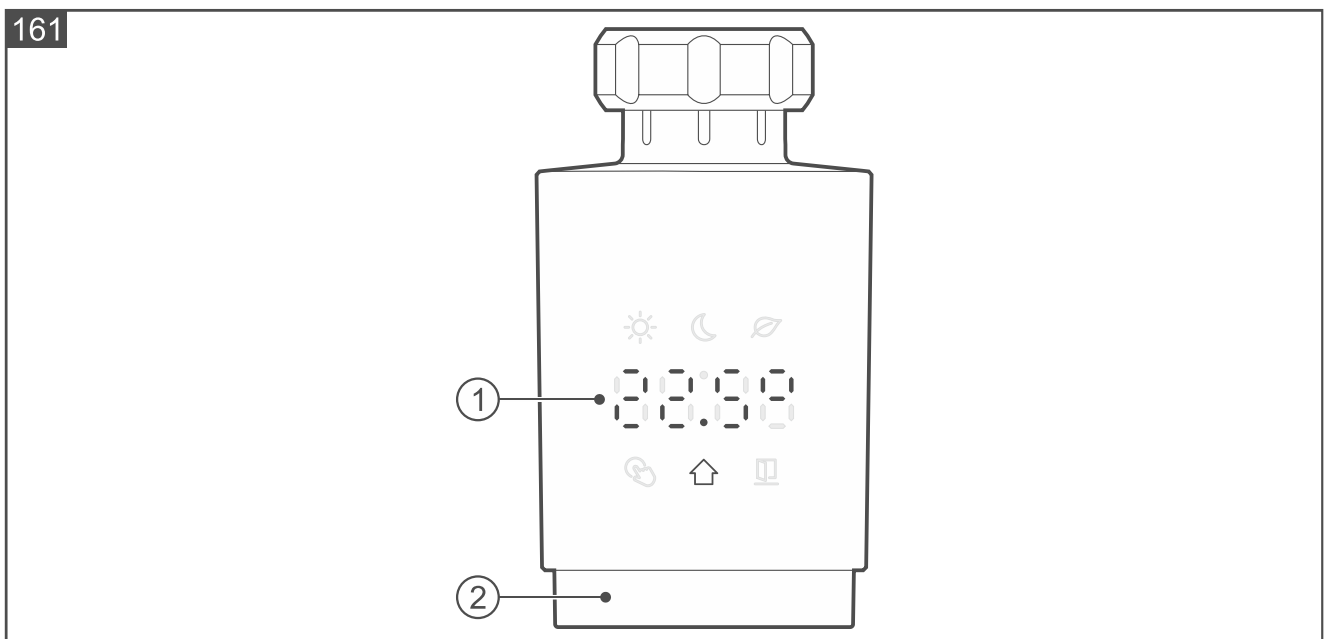

① LED display.

② knob.







#### 9.1.1 LED display

Normally, the display is off. Touch the knob (Fig. 119) to turn on the display.





After turning on, the display shows temperature in degrees Celsius from the selected sensor (Fig. 154). Symbols and messages are also displayed.









The display will be turned off after 20 seconds since your last activity using the knob.

#### Symbols on the display

-  temperature set for the day is displayed.
-  temperature set for the night is displayed.
-  temperature set for the *ECO* operating mode is displayed.
-  temperature set manually is displayed.
-  temperature from the sensor is displayed.
-  open window has been detected and the valve is closed.

#### Messages on the display

-  thermostat ready for calibration to be started. Press the knob to start the calibration.
-  thermostat adaptation in progress.
-  the knob is blocked. Press and hold the knob for 3 seconds to unblock it. The knob can be unblocked if it has been blocked manually. If the Child Lock option is enabled in the Be Wave app, then knob cannot be unblocked manually.
-  low batteries (battery voltage dropped below 2.3 V). Replace the batteries.
-  anti-freeze protection is enabled.

-  Boost Heat is enabled (number at the end is the minutes remaining until the end of the function). If you want to stop the Boost Heat, press and hold the knob for 3 seconds.
-  valve is closed. Press or turn the knob to open the valve.
-  trouble with changing the valve position. Make sure the thermostat is mounted correctly on the valve and check the valve operation or restart the thermostat (remove the batteries and insert them again).
-  incorrect operating range of the thermostat (calibration failure). Make sure the thermostat is mounted correctly on the valve or restart the thermostat (remove the batteries and insert them again).
-  valve control disabled to protect against complete battery discharge (battery voltage dropped below 2.2 V). Replace the batteries.
-  problem with the knob.
-  motor error.
-  internal error.
-  unable to fully close the valve (calibration failure). Make sure the thermostat is mounted correctly on the valve or restart the thermostat (remove the batteries and insert them again).

### Rotating the temperature / messages on the display by 180°

1. Remove the thermostat cover (Fig. 117).
2. Remove the batteries.
3. Install the batteries again. The  message will be displayed.
4. Press and hold the knob for 5 seconds (Fig. 119). The message on the display will be rotated by 180°.
5. Replace the thermostat cover (Fig. 118).

#### 9.1.2 Knob

**Press** (Fig. 119) – turn on the display / change the operating mode / confirm new temperature settings.

**Press and hold for 3 seconds** – block the knob / unblock the knob / edit temperature for the selected operating mode / stop the Boost Heat.

**Turn right** – temperature up.

**Turn left** – temperature down.

**Press and turn right** – start the Boost Heat.

**Press and turn left** – fully close the valve.

#### 9.1.3 Changing the operating mode manually

1. Press the knob to turn on the display.
2. Keep pressing the knob until the temperature for the operating mode you want to enable is displayed.
3. Wait 10 seconds. The temperature from the selected sensor will be displayed.

#### 9.1.4 Temporarily setting other temperature



*This temporary temperature will be used until the operating mode is changed.*

*This function is not available when the ECO operating mode is enabled. First change the operating mode, then change the temperature.*

1. Press the knob to turn on the display.
2. Press the knob to display the currently set temperature.
3. Turn the knob to set the new temperature.
4. Press the knob to confirm the change.

### 9.1.5 Changing the temperature setting for the selected operating mode

1. Press the knob to turn on the display.
2. Keep pressing the knob until the temperature for the operating mode you want to edit is displayed.
3. Press and hold the knob for 3 seconds. The temperature on the display will start flashing.
4. Turn the knob to set the new temperature.
5. Press the knob to confirm the change.
6. Keep pressing the knob until the temperature for the operating mode you want to enable is displayed.

## 9.2 Manual control of the Smart Plug

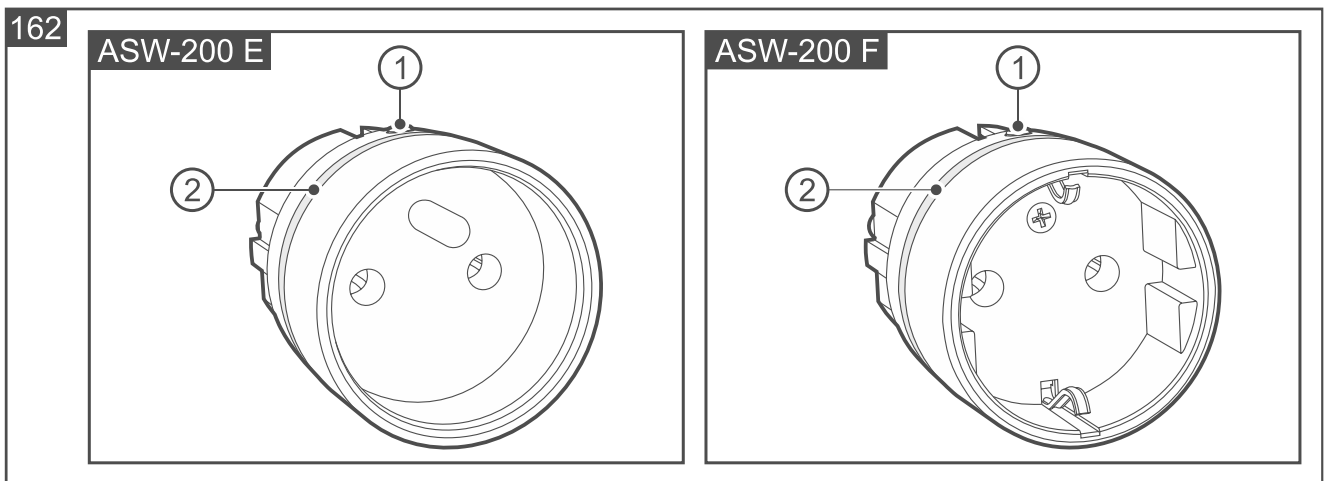

- ① LED indicator.  
 ② button.

### 9.2.1 LED indicator

You can configure the LED indicator in the Be Wave app. When enabled, the LED indicator indicates:

**ON** – plug is turned on. In the app you can select whether the color should be dependent on the power consumption or it should be one color.

**flashing in yellow** – plug is turned off due to overload. The power consumption of the appliance connected to the plug exceeds 2300 W and the plug cannot control it.

**flashing in red** – plug is turned off due to overheating. The plug will go back to work when it cools down.

### 9.2.2 Button

**Press** – turn on / off the plug (device connected to the plug).

**Press and hold for 10 seconds** – block / unblock the capability to add the plug to the system.

## 10. Specifications

---

### 10.1 Smart HUB Plus / Smart HUB

---

Operating frequency band.....	868.0 MHz ÷ 868.6 MHz
Radio communication range (in open area) .....	up to 2000 m
Supply voltage .....	230 VAC, 50 Hz
Rechargeable battery.....	18650 3.6 V / 3200 mAh
Standby power consumption	
Smart HUB Plus .....	1.85 W
Smart HUB .....	1.82 W
Maximum power consumption	
Smart HUB Plus .....	2.8 W
Smart HUB .....	2.65 W
Standby current consumption from battery	
Smart HUB Plus .....	272 mA
Smart HUB .....	252 mA
Battery charging current.....	185 mA
Low battery voltage threshold .....	3.2 V
Battery cut-off voltage .....	2.7 V
Battery operating temperature	
discharging .....	-10°C...+60°C
charging.....	0°C...+45°C
Supported memory cards.....	microSD, micro SDHC
Security grade according to EN 50131-1 .....	Grade 2
Complied with standards. EN 50130-4, EN 50130-5, EN 50131-1, EN 50131-3, EN 50131-5-3	
Environmental class according to EN 50130-5 .....	II
Operating temperature range.....	-10°C...+55°C
Maximum humidity .....	93±3%
Dimensions .....	158 x 158 x 30 mm
Weight	
Smart HUB Plus .....	411 g
Smart HUB .....	406 g

### 10.2 Smart HUB Plus LV

---

Operating frequency band.....	868.0 MHz ÷ 868.6 MHz
Radio communication range (in open area) .....	up to 2000 m
Supply voltage .....	9...28 VDC
Rechargeable battery.....	18650 3.6 V / 3200 mAh
Standby current consumption	
9 VDC power .....	113 mA
28 VDC power .....	42 mA
Maximum current consumption	
9 VDC power .....	240 mA

28 VDC power .....	60 mA
Standby current consumption from battery .....	220 mA
Battery charging current.....	205 mA
Low battery voltage threshold .....	3.2 V
Battery cut-off voltage .....	2.7 V
Battery operating temperature	
discharging .....	-10°C...+60°C
charging.....	0°C...+45°C
Supported memory cards.....	microSD, micro SDHC
Security grade according to EN 50131-1 .....	Grade 2
Complied with standards..EN 50130-4, EN 50130-5, EN 50131-1, EN 50131-3, EN 50131-5-3	
Environmental class according to EN 50130-5 .....	II
Operating temperature range.....	-10°C...+55°C
Maximum humidity .....	93±3%
Dimensions .....	158 x 158 x 30 mm
Weight.....	324 g

### 10.3 Smart Keypad (AKP-200)

Operating frequency band .....	868.0 MHz ÷ 868.6 MHz
Radio communication range (in open area) .....	up to 1100 m
Batteries.....	2 x LR6 AA 1.5 V
Standby current consumption from battery .....	155 µA
Low battery voltage threshold .....	2.45 V
Supply voltage (external power supply) .....	5... 12 VDC
Standby current consumption from APS-055 power supply.....	27 mA
Maximum current consumption from APS-055 power supply .....	50 mA
Security grade according to EN 50131-1 .....	Grade 2
Complied with standards.....	EN 50131-1, EN 50130-4, EN 50130-5
Environmental class according to EN50130-5 .....	II
Operating temperature range.....	-10°C...+50°C
Maximum humidity .....	93±3%
Dimensions .....	45 x 128 x 21 mm
Weight.....	75 g

**Hereby, SATEL sp. z o.o. declares that the radio equipment type AKP-200 is in compliance with Directive 2014/53/EU. The full text of the EU declaration of conformity is available at the following internet address: [www.satel.pl/ce](http://www.satel.pl/ce)**

### 10.4 Motion Detector (APD-200)

Operating frequency band .....	868.0 MHz ÷ 868.6 MHz
Radio communication range (in open area) .....	up to 1800 m
Battery .....	CR123A 3 V
Battery life.....	up to 2 years

Standby current consumption .....	70 $\mu$ A
Low battery voltage threshold .....	2.75 V
Temperature measurement range .....	-10°C...+55°C
Temperature measurement accuracy .....	$\pm$ 1°C
Detectable speed .....	0.3...3 m/s
Warm-up period .....	35 s
Recommended installation height .....	2 m...2.4 m
Maximum coverage area.....	15 m x 24 m, 90°
Complied with standards.....	EN 50131-1, EN 50130-4, EN 50130-5
Security grade according to EN 50131-2-2 (detector mounted directly to the wall).....	Grade 2
Environmental class according to EN 50130-5 .....	II
Operating temperature range.....	-10°C...+55°C
Maximum humidity .....	93 $\pm$ 3%
Dimensions .....	62 x 137 x 42 mm
Weight.....	132 g

**Hereby, SATEL sp. z o.o. declares that the radio equipment type APD-200 is in compliance with Directive 2014/53/EU. The full text of the EU declaration of conformity is available at the following internet address: [www.satel.pl/ce](http://www.satel.pl/ce)**

## **10.5 Motion Detector Pet (APD-200 Pet)**

Operating frequency band.....	868.0 MHz $\div$ 868.6 MHz
Radio communication range (in open area) .....	up to 1800 m
Battery.....	CR123A 3 V
Battery life .....	up to 2 years
Standby current consumption .....	70 $\mu$ A
Low battery voltage threshold .....	2.75 V
Temperature measurement range .....	-10°C...+55°C
Temperature measurement accuracy .....	$\pm$ 1°C
Detectable speed .....	0.3...3 m/s
Warm-up period .....	35 s
Recommended installation height .....	2.4 m
Maximum coverage area.....	14 m x 16 m, 83°
Complied with standards.....	EN 50131-1, EN 50130-4, EN 50130-5
Security grade according to EN 50131-2-2 .....	Grade 2
Environmental class according to EN 50130-5 .....	II
Operating temperature range.....	-10°C...+55°C
Maximum humidity .....	93 $\pm$ 3%
Dimensions .....	62 x 137 x 42 mm
Weight.....	107 g

**Hereby, SATEL sp. z o.o. declares that the radio equipment type APD-200 Pet is in compliance with Directive 2014/53/EU. The full text of the EU declaration of conformity is available at the following internet address: [www.satel.pl/ce](http://www.satel.pl/ce)**

## 10.6 Motion Detector Cam (APCAM-200)

Operating frequency band .....	868.0 MHz ÷ 868.6 MHz
Radio communication range (in open area) .....	up to 1800 m
Battery .....	CR123A 3 V
Battery life .....	up to 2 years
Standby current consumption from battery .....	90 µA
Low battery voltage threshold .....	2.75 V
Supply voltage (external power supply) .....	5...12 VDC
Standby current consumption from APS-055 power supply .....	16 mA
Maximum current consumption from APS-055 power supply .....	710 mA
Temperature measurement range .....	-10°C...+55°C
Temperature measurement accuracy .....	±1°C
Detectable speed .....	0.3...3 m/s
Warm-up period .....	35 s
Camera	
Image resolution .....	640 x 480 pixels
Image file format .....	JPG
Number of photos after alarm .....	3
Recommended installation height .....	2 m...2.4 m
Maximum coverage area .....	15 m x 24 m, 90°
Complied with standards .....	EN 50131-1, EN 50130-4, EN 50130-5
Security grade according to EN 50131-2-2 .....	Grade 2
Environmental class according to EN 50130-5 .....	II
Operating temperature range .....	-10°C...+55°C
Maximum humidity .....	93±3%
Dimensions .....	62 x 137 x 43 mm
Weight .....	159 g

**Hereby, SATEL sp. z o.o. declares that the radio equipment type APCAM-200 is in compliance with Directive 2014/53/EU. The full text of the EU declaration of conformity is available at the following internet address: [www.satel.pl/ce](http://www.satel.pl/ce)**

## 10.7 Motion Detector Plus (APMD-250)

Operating frequency band .....	868.0 MHz ÷ 868.6 MHz
Radio communication range (in open area) .....	up to 1800 m
Battery .....	CR123A 3 V
Battery life .....	up to 2 years
Standby current consumption .....	75 µA

Low battery voltage threshold .....	2.75 V
Temperature measurement range .....	-10°C...+55°C
Temperature measurement accuracy .....	±1°C
Microwave frequency .....	24.125 GHz
Detectable speed .....	0.3...3 m/s
Warm-up period .....	40 s
Recommended installation height .....	2 m...2.4 m
Maximum coverage area.....	15 m x 24 m, 90°
Complied with standards.....	EN 50131-1, EN 50130-4, EN 50130-5
Security grade according to EN 50131-2-4 (detector mounted directly to the wall).....	Grade 2
Environmental class according to EN 50130-5 .....	II
Operating temperature range.....	-10°C...+55°C
Maximum humidity .....	93±3%
Dimensions .....	62 x 137 x 42 mm
Weight.....	152 g

**Hereby, SATEL sp. z o.o. declares that the radio equipment type APMD-250 is in compliance with Directive 2014/53/EU. The full text of the EU declaration of conformity is available at the following internet address: [www.satel.pl/ce](http://www.satel.pl/ce)**

## **10.8 Outdoor Motion Detector (AOD-210)**

Operating frequency band.....	868.0 MHz ÷ 868.6 MHz
Radio communication range (in open area) .....	up to 1500 m
Battery.....	CR123A 3 V
Battery life .....	up to 2 years
Standby current consumption .....	75 µA
Low battery voltage threshold .....	2.75 V
Light intensity measurement range .....	2 lx...250 lx
Temperature measurement range .....	-40°C...+55°C
Temperature measurement accuracy .....	±1°C
Microwave frequency .....	24.125 GHz
Detectable speed .....	0.3...3 m/s
Warm-up period .....	40 s
Recommended installation height .....	2.4 m
Maximum coverage area.....	16 m x 16 m, 90°
Complied with standards.....	EN 50131-1, EN 50130-4, EN 50130-5
Security grade according to EN 50131-2-4 .....	Grade 2
Environmental class according to EN 50130-5 .....	IIla
Operating temperature range.....	-40°C...+55°C
Maximum humidity .....	93±3%
IP code.....	IP54
Dimensions .....	65 x 138 x 58 mm
Weight.....	182 g

**Hereby, SATEL sp. z o.o. declares that the radio equipment type AOD-210 is in compliance with Directive 2014/53/EU. The full text of the EU declaration of conformity is available at the following internet address: [www.satel.pl/ce](http://www.satel.pl/ce)**

## 10.9 Curtain Detector (ACD-220)

Operating frequency band .....	868.0 MHz ÷ 868.6 MHz
Radio communication range (in open area) .....	up to 1300 m
Battery .....	CR123A 3 V
Battery life.....	up to 2 years
Standby current consumption .....	70 µA
Low battery voltage threshold .....	2.75 V
Temperature measurement range .....	-10°C...+55°C
Temperature measurement accuracy .....	±1°C
Detectable speed .....	0.3...1 m/s
Warm-up period .....	5 s
Maximum coverage area .....	5 m x 1 m, 15°
Complied with standards.....	EN 50130-4, EN 50130-5
Environmental class according to EN 50130-5 .....	II
Operating temperature range.....	-10°C...+55°C
Maximum humidity .....	93±3%
Dimensions .....	20 x 102 x 25 mm
Weight.....	43 g

**Hereby, SATEL sp. z o.o. declares that the radio equipment type ACD-220 is in compliance with Directive 2014/53/EU. The full text of the EU declaration of conformity is available at the following internet address: [www.satel.pl/ce](http://www.satel.pl/ce)**

## 10.10 Outdoor Curtain Detector (AOCD-260)

Operating frequency band .....	868.0 MHz ÷ 868.6 MHz
Radio communication range (in open area) .....	up to 1300 m
Battery .....	CR123A 3 V
Battery life.....	up to 2 years
Standby current consumption .....	70 µA
Low battery voltage threshold .....	2.75 V
Temperature measurement range .....	-40°C...+55°C
Temperature measurement accuracy .....	±1°C
Microwave frequency .....	24.125 GHz
Detectable speed .....	0.3...3 m/s
Warm-up period .....	45 s
Recommended installation height.....	2.4 m
Maximum coverage area .....	10 m x 0.6 m, 6°

Complied with standards.....	EN 50131-1, EN 50130-4, EN 50130-5
Security grade according to EN 50131-2-4 (detector mounted directly to the wall).....	Grade 2
Environmental class according to EN 50130-5 .....	IIIa
Operating temperature range.....	-40°C...+55°C
Maximum humidity .....	93±3%
IP code.....	IP54
Dimensions .....	44 x 105 x 40 mm
Weight.....	118 g

**Hereby, SATEL sp. z o.o. declares that the radio equipment type AOCD-260 is in compliance with Directive 2014/53/EU. The full text of the EU declaration of conformity is available at the following internet address: [www.satel.pl/ce](http://www.satel.pl/ce)**

### **10.11 Glass Break Detector (AGD-200)**

Operating frequency band.....	868.0 MHz ÷ 868.6 MHz
Radio communication range (in open area) .....	up to 1300 m
Battery.....	CR123A 3 V
Battery life .....	up to 2 years
Standby current consumption .....	90 µA
Low battery voltage threshold .....	2.75 V
Temperature measurement range .....	-10°C...+55°C
Temperature measurement accuracy .....	±1°C
Detection range.....	up to 6 m
Complied with standards.....	EN 50130-4, EN 50130-5, EN 50131-5-3
Environmental class according to EN 50130-5 .....	II
Operating temperature range.....	-10°C...+55°C
Maximum humidity .....	93±3%
Dimensions .....	20 x 102 x 23 mm
Weight.....	39 g

**Hereby, SATEL sp. z o.o. declares that the radio equipment type AGD-200 is in compliance with Directive 2014/53/EU. The full text of the EU declaration of conformity is available at the following internet address: [www.satel.pl/ce](http://www.satel.pl/ce)**

### **10.12 Multipurpose Detector (AXD-200)**

Operating frequency band.....	868.0 MHz ÷ 868.6 MHz
Radio communication range (in open area) .....	up to 1300 m
Battery.....	CR123A 3 V
Battery life .....	up to 2 years
Standby current consumption .....	55 µA
Low battery voltage threshold .....	2.75 V
M1 input (NC) sensitivity .....	240 ms

Temperature measurement range .....	-10°C...+55°C
Temperature measurement accuracy .....	±1°C
Complied with standards	EN 50130-4, EN 50130-5, EN 50131-1, EN 50131-2-6, EN 50131-5-3
Security grade according to EN 50131-2-6 .....	Grade 2
Environmental class according to EN 50130-5 .....	II
Operating temperature range.....	-10°C...+55°C
Maximum humidity .....	93±3%
Enclosure dimensions.....	20 x 102 x 23 mm
Surface mounted magnet enclosure dimensions .....	15 x 52 x 6 mm
Surface mounted magnet spacer dimensions.....	15 x 52 x 6 mm
Flush mounted magnet enclosure dimensions.....	∅10 x 28 mm
Weight.....	59 g

### Opening detector / Shock and opening detector

Maximum gap

surface magnet .....	20 mm
flush magnet .....	18 mm

### Shock detector / Shock and opening detector

Shock detection range (depending on the surface type)..... up to 3 m



*This range is for reference only. Please test the actual range when mounting the detector.*

**Hereby, SATEL sp. z o.o. declares that the radio equipment type AXD-200 is in compliance with Directive 2014/53/EU. The full text of the EU declaration of conformity is available at the following internet address: [www.satel.pl/ce](http://www.satel.pl/ce)**

## 10.13 Opening Detector (AXD-200 Lite)

Operating frequency band .....	868.0 MHz ÷ 868.6 MHz
Radio communication range (in open area).....	up to 1300 m
Battery .....	CR123A 3 V
Battery life.....	up to 2 years
Standby current consumption .....	48 µA
Low battery voltage threshold .....	2.75 V
Maximum gap	
surface magnet .....	20 mm
flush magnet .....	18 mm
M1 input (NC) sensitivity .....	240 ms
Complied with standards.....	EN 50130-4, EN 50130-5, EN 50131-1, EN 50131-2-6, EN 50131-5-3
Security grade according to EN 50131-2-6 .....	Grade 2
Environmental class according to EN 50130-5 .....	II
Operating temperature range.....	-10°C...+55°C
Maximum humidity .....	93±3%
Enclosure dimensions.....	20 x 102 x 23 mm

Surface mounted magnet enclosure dimensions .....	15 x 52 x 6 mm
Surface mounted magnet spacer dimensions .....	15 x 52 x 6 mm
Flush mounted magnet enclosure dimensions .....	ø10 x 28 mm
Weight.....	59 g

**Hereby, SATEL sp. z o.o. declares that the radio equipment type AXD-200 Lite is in compliance with Directive 2014/53/EU. The full text of the EU declaration of conformity is available at the following internet address: [www.satel.pl/ce](http://www.satel.pl/ce)**

### 10.14 Flood Detector (AFD-200)

Operating frequency band.....	868.0 MHz ÷ 868.6 MHz
Radio communication range (in open area) .....	up to 1300 m
Battery.....	CR123A 3 V
Battery life .....	up to 5 years
Standby current consumption .....	45 µA
Low battery voltage threshold .....	2.75 V
Temperature measurement range .....	-10°C...+55°C
Temperature measurement accuracy .....	±1°C
Environmental class according to EN 50130-5 .....	II
Operating temperature range.....	-10°C...+55°C
Maximum humidity .....	93±3%
IP code.....	X4
Dimensions .....	65 x 65 x 24 mm
Weight.....	47 g

**Hereby, SATEL sp. z o.o. declares that the radio equipment type AFD-200 is in compliance with Directive 2014/53/EU. The full text of the EU declaration of conformity is available at the following internet address: [www.satel.pl/ce](http://www.satel.pl/ce)**

### 10.15 Fire Detector Plus (ASD-200)

Operating frequency band.....	868.0 MHz ÷ 868.6 MHz
Radio communication range (in open area) .....	up to 1200 m
Battery.....	CR123A 3 V
Battery life .....	up to 2 years
Standby current consumption .....	30 µA
Low battery voltage threshold .....	2.75 V
Static response temperature .....	54°C
Temperature measurement range .....	0°C...+55°C
Temperature measurement accuracy .....	±1°C
Operating temperature range.....	0°C...+55°C
Maximum humidity .....	93±3%
Enclosure dimensions.....	ø108 x 61 mm

Weight..... 172 g

**Hereby, SATEL sp. z o.o. declares that the radio equipment type ASD-200 is in compliance with Directive 2014/53/EU. The full text of the EU declaration of conformity is available at the following internet address: [www.satel.pl/ce](http://www.satel.pl/ce)**

## 10.16 Fire Detector Pro (ASD-250)

Operating frequency band .....868.0 MHz ÷ 868.6 MHz  
 Radio communication range (in open area) ..... up to 1200 m  
 Battery ..... CR123A 3 V  
 Battery life..... up to 2 years  
 Standby current consumption .....90 µA  
 Low battery voltage threshold.....2.75 V  
 Operating temperature range..... 0°C...+55°C  
 Maximum humidity ..... 93±3%  
 Dimensions ..... ø108 x 54 mm  
 Weight..... 172 g

**Hereby, SATEL sp. z o.o. declares that the radio equipment type ASD-250 is in compliance with Directive 2014/53/EU. The full text of the EU declaration of conformity is available at the following internet address: [www.satel.pl/ce](http://www.satel.pl/ce)**

The ASD-250 wireless smoke detector conforms to the essential requirements of the EU Regulations and Directives:

**CPR** 305/2011 Regulation of the European Parliament and of the Council of 9 March 2011 laying down harmonized conditions for the marketing of construction products and repealing the Council Directive 89/106/EEC on construction products;

**RED** Directive 2014/53/EU of the European Parliament and of the Council of 16 April 2014 on the harmonization of the laws of the Member States relating to the making available on the market of radio equipment and repealing Directive 1999/5/EC.

The CNBOP-PIB Certification Body in Józefów issued the Certificate of Constancy of Performance 1438-CPR-0645 for the construction product ASD-250 Wireless Smoke Detector, confirming its compliance with the requirements of EN 14604:2006.

The CNBOP-PIB Certification Body in Józefów has tested the ASD-250 Wireless Smoke Detector confirming its compliance with the EN 14604 Standard, within the scope of Appendix L (approved for the use in caravans and camper vans).

The Certificate and the Declaration of Performance can be downloaded from the [www.satel.pl](http://www.satel.pl) website.



SATEL Sp. z o.o. • ul. Budowlanych 66 • 80-298 Gdańsk • POLAND

1438

1438-CPR-0645

DOP/CPR/0645

EN 14604

**Fire safety. ASD-250 wireless smoke detector, stand-alone, capable of interacting over the air with the intruder alarm system, based on scattered light principle, designed for indoor use.**

Declaration of Performance DOP/CPR/0645

Application – fire safety.

Technical specifications – see this manual.

### 10.17 Carbon Monoxide Detector (ACMD-200)

Operating frequency band.....	868.0 MHz ÷ 868.6 MHz
Radio communication range (in open area) .....	up to 1500 m
Battery.....	CR123A 3 V
Battery life .....	up to 2 years
Standby current consumption .....	62 µA
Low battery voltage threshold .....	2.75 V
Temperature measurement range .....	0°C...+55°C
Temperature measurement accuracy .....	±1°C
Operating temperature range.....	0°C...+55°C
Maximum humidity .....	93±3%
Dimensions .....	ø108 x 54 mm
Weight.....	153 g

**Hereby, SATEL sp. z o.o. declares that the radio equipment type ACMD-200 is in compliance with Directive 2014/53/EU. The full text of the EU declaration of conformity is available at the following internet address: [www.satel.pl/ce](http://www.satel.pl/ce)**

### 10.18 Outdoor Dusk Detector (ADD-200)

Operating frequency band.....	868.0 MHz ÷ 868.6 MHz
Radio communication range (in open area) .....	up to 1300 m
Battery.....	CR123A 3 V
Battery life .....	up to 2 years
Standby current consumption .....	20 µA
Low battery voltage threshold .....	2.75 V
Light intensity measurement range .....	2 lx...250 lx
Temperature measurement range .....	-20°C...+55°C
Temperature measurement accuracy .....	±1°C

Warm-up period .....	5 s
Environmental class according to EN 50130-5 .....	III
Operating temperature range.....	-20°C...+55°C
Maximum humidity .....	93±3%
IP code.....	IP65
Dimensions .....	58 x 115 x 34 mm
Weight.....	95 g

**Hereby, SATEL sp. z o.o. declares that the radio equipment type ADD-200 is in compliance with Directive 2014/53/EU. The full text of the EU declaration of conformity is available at the following internet address: [www.satel.pl/ce](http://www.satel.pl/ce)**

### 10.19 Multi Sensor (ATPH-200)

Operating frequency band .....	868.0 MHz ÷ 868.6 MHz
Radio communication range (in open area) .....	up to 1300 m
Battery .....	CR123A 3 V
Battery life.....	up to 5 years
Standby current consumption .....	48 µA
Low battery voltage threshold .....	2.75 V
Temperature measurement range .....	-10°C...+55°C
Temperature measurement accuracy .....	±0.2°C
Temperature measurement resolution .....	0.1°C
Pressure measurement range .....	260...1260 hPa
Pressure measurement accuracy .....	±0.1 hPa
Pressure measurement resolution .....	0.1 hPa
Humidity measurement range.....	0%RH...93%RH
Humidity measurement accuracy.....	±1.5%RH
Humidity measurement resolution .....	0.1%RH
Environmental class according to EN 50130-5 .....	II
Operating temperature range.....	-10°C...+55°C
Maximum humidity .....	93±3%
Dimensions .....	20 x 102 x 23 mm
Weight.....	43 g

**Hereby, SATEL sp. z o.o. declares that the radio equipment type ATPH-200 is in compliance with Directive 2014/53/EU. The full text of the EU declaration of conformity is available at the following internet address: [www.satel.pl/ce](http://www.satel.pl/ce)**

### 10.20 Outdoor Siren (ASP-200)

Operating frequency band .....	868.0 MHz ÷ 868.6 MHz
Radio communication range (in open area) .....	up to 2000 m
Battery .....	ER34615 3.6 V

Battery life .....	up to 2.5 years
Standby current consumption .....	650 $\mu$ A
Sound pressure level (at 1 m distance).....	up to 105 dB
Complied with standards. EN 50130-4, EN 50130-5, EN 50131-1, EN 50131-4, EN 50131-5-3	
Security grade according to EN 50131-1 .....	Grade 2
Environmental class according to EN 50130-5 .....	IIIA
Operating temperature range.....	-40°C ...+55°C
Maximum humidity .....	93 $\pm$ 3%
Dimensions .....	148 x 254 x 64 mm
Weight.....	762 g

**Hereby, SATEL sp. z o.o. declares that the radio equipment type ASP-200 is in compliance with Directive 2014/53/EU. The full text of the EU declaration of conformity is available at the following internet address: [www.satel.pl/ce](http://www.satel.pl/ce)**

## 10.21 Indoor Siren (ASP-215)

Operating frequency band.....	868.0 MHz $\div$ 868.6 MHz
Radio communication range (in open area) .....	up to 1500 m
Battery.....	CR123A 3 V
Battery life .....	up to 2 years
Standby current consumption .....	70 $\mu$ A
Low battery voltage threshold .....	2.75 V
Temperature measurement range .....	-10°C...+55°C
Temperature measurement accuracy .....	$\pm$ 1°C
Sound pressure level (at 1 m distance).....	up to 105 dB
Complied with standards. EN 50130-4, EN 50130-5, EN 50131-1, EN 50131-4, EN 50131-5-3	
Security grade according to EN 50131-1 .....	Grade 2
Environmental class according to EN 50130-5 .....	II
Operating temperature range.....	-10°C...+55°C
Maximum humidity .....	93 $\pm$ 3%
Dimensions .....	87 x 133 x 37 mm
Weight.....	180 g

**Hereby, SATEL sp. z o.o. declares that the radio equipment type ASP-215 is in compliance with Directive 2014/53/EU. The full text of the EU declaration of conformity is available at the following internet address: [www.satel.pl/ce](http://www.satel.pl/ce)**

## 10.22 Mini Multi Extender (ACX-210)

Operating frequency band.....	868.0 MHz $\div$ 868.6 MHz
Radio communication range (in open area) .....	up to 1400 m
Supply voltage .....	4...24 VDC
Standby current consumption .....	30 mA

Maximum current consumption .....	35 mA
OC type low-current outputs .....	50 mA / 12 VDC
Complied with standards.....	EN 50130-4, EN 50130-5
Environmental class according to EN50130-5 .....	II
Operating temperature range.....	-10°C...+55°C
Maximum humidity .....	93±3%
Dimensions .....	21 x 41 x 13 mm
Weight.....	10 g

**Hereby, SATEL sp. z o.o. declares that the radio equipment type ACX-210 is in compliance with Directive 2014/53/EU. The full text of the EU declaration of conformity is available at the following internet address: [www.satel.pl/ce](http://www.satel.pl/ce)**

### **10.23 Multi Extender (ACX-220)**

Operating frequency band .....	868.0 MHz ÷ 868.6 MHz
Radio communication range (in open area) .....	up to 1300 m
Supply voltage .....	12 VDC ±15%
Standby current consumption .....	35 mA
Maximum current consumption .....	120 mA
Relay outputs (resistive load).....	1000 mA / 24 VDC
Complied with standards.....	EN 50130-4, EN 50130-5, EN 50131-1, EN 50131-3, EN 50131-5-3
Environmental class according to EN50130-5 .....	II
Operating temperature range.....	-10°C...+55°C
Maximum humidity .....	93±3%
Enclosure dimensions.....	126 x 158 x 32 mm
Weight.....	204 g

**Hereby, SATEL sp. z o.o. declares that the radio equipment type ACX-220 is in compliance with Directive 2014/53/EU. The full text of the EU declaration of conformity is available at the following internet address: [www.satel.pl/ce](http://www.satel.pl/ce)**

### **10.24 Smart Dimmer (ADC-200)**

Operating frequency band .....	868.0 MHz ÷ 868.6 MHz
Radio communication range (in open area) .....	up to 800 m
Supply voltage .....	230 VAC, 50 Hz
Standby power consumption.....	0.6 W
Maximum power consumption .....	1 W
Minimum load .....	1 W / 230 VAC
Maximum load .....	0.7 A / 150 W / 230 VAC
Complied with standards.....	EN 50130-4, EN 50130-5
Environmental class according to EN 50130-5 .....	II
Operating temperature range.....	-10°C...+55°C

Maximum humidity .....	93±3%
Dimensions .....	47 x 47 x 22 mm
Weight.....	33 g

**Hereby, SATEL sp. z o.o. declares that the radio equipment type ADC-200 is in compliance with Directive 2014/53/EU. The full text of the EU declaration of conformity is available at the following internet address: [www.satel.pl/ce](http://www.satel.pl/ce)**

## **10.25 Smart RGBW LED Driver (ARC-200)**

Operating frequency band.....	868.0 MHz ÷ 868.6 MHz
Radio communication range (in open area) .....	up to 1200 m
Supply voltage .....	12...48 VDC
Standby power consumption.....	0.2 W
Maximum power consumption .....	1 W
Maximum output load	
4 outputs used .....	4 A / 125 W / 12...48 VDC
2 outputs used .....	8 A / 192 W / 12...24 VDC
Complied with standards.....	EN 50130-4, EN 50130-5
Environmental class according to EN50130-5 .....	II
Operating temperature range.....	-10°C...+55°C
Maximum humidity .....	93±3%
Dimensions .....	47 x 47 x 22 mm
Weight.....	34 g

**Hereby, SATEL sp. z o.o. declares that the radio equipment type ARC-200 is in compliance with Directive 2014/53/EU. The full text of the EU declaration of conformity is available at the following internet address: [www.satel.pl/ce](http://www.satel.pl/ce)**

## **10.26 Smart Blinds (ARSC-200)**

Operating frequency band.....	868.0 MHz ÷ 868.6 MHz
Radio communication range (in open area) .....	up to 1000 m
Supply voltage .....	230 VAC, 50 Hz
Standby power consumption.....	0.45 W
Maximum power consumption .....	1 W
Maximum load.....	1.7 A / 350 W / 230 VAC
Complied with standards.....	EN 50130-4, EN 50130-5
Environmental class according to EN 50130-5 .....	II
Operating temperature range.....	-10°C...+55°C
Maximum humidity .....	93±3%
Dimensions .....	47 x 47 x 22 mm
Weight.....	41 g

**Hereby, SATEL sp. z o.o. declares that the radio equipment type ARSC-200 is in compliance with Directive 2014/53/EU. The full text of the EU declaration of conformity is available at the following internet address: [www.satel.pl/ce](http://www.satel.pl/ce)**

## 10.27 Smart Thermostat (ART-210)

Operating frequency band .....	868.0 MHz ÷ 868.6 MHz
Radio communication range (in open area) .....	up to 1000 m
Batteries.....	2 x LR6 AA 1.5 V
Battery life.....	up to 2 years
Standby current consumption .....	74 µA
Low battery voltage threshold.....	2.3 V
Temperature measurement range .....	-10°C...+50°C
Temperature measurement accuracy .....	±0.1°C
Temperature adjustment range.....	5°C...30°C
Temperature adjustment accuracy .....	±0.5°C
Operating temperature range.....	-10°C...+50°C
Maximum humidity .....	93±3%
Enclosure dimensions.....	ø56 x 97 mm
Weight.....	166 g

**Hereby, SATEL sp. z o.o. declares that the radio equipment type ART-210 is in compliance with Directive 2014/53/EU. The full text of the EU declaration of conformity is available at the following internet address: [www.satel.pl/ce](http://www.satel.pl/ce)**

## 10.28 Smart Plug (ASW-200)

Operating frequency band .....	868.0 MHz ÷ 868.6 MHz
Radio communication range (in open area) .....	up to 1300 m
Supply voltage .....	230 VAC, 50 Hz
Standby power consumption.....	0.73 W
Maximum power consumption .....	1.37 W
Rated current (resistive load).....	10 A
Complied with standards.....	EN 50130-4, EN 50130-5
Environmental class according to EN 50130-5 .....	II
Operating temperature range.....	-10°C...+55°C
Maximum humidity .....	93±3%
Dimensions:	
ASW-200 E.....	ø45 x 67 mm
ASW-200 F.....	ø45 x 70 mm
Weight:	
ASW-200 E.....	60 g
ASW-200 F.....	61 g

**Hereby, SATEL sp. z o.o. declares that the radio equipment type ASW-200 is in compliance with Directive 2014/53/EU. The full text of the EU declaration of conformity is available at the following internet address: [www.satel.pl/ce](http://www.satel.pl/ce)**

### 10.29 Smart 2-CH Relay (ASW-210)

Operating frequency band.....	868.0 MHz ÷ 868.6 MHz
Radio communication range (in open area) .....	up to 1300 m
Supply voltage .....	230 VAC, 50 Hz
Standby power consumption.....	0.47 W
Maximum power consumption .....	1 W
Rated switching voltage .....	250 VAC
Relay outputs rated load – AC1 .....	5 A / 250 VAC
Minimum switching current.....	10 mA
Rated switching current.....	5 A
Maximum breaking capacity – AC1.....	1250 VA
Minimum breaking capacity.....	50 mW
Contact resistance .....	≤ 100 mΩ
Electrical life (number of cycles) – AC1 (360 cycles/hour) .....	> 10 <sup>5</sup>
Complied with standards.....	EN 50130-4, EN 50130-5
Environmental class according to EN 50130-5 .....	II
Operating temperature range.....	-10°C...+55°C
Maximum humidity .....	93±3%
Dimensions .....	47 x 47.4 x 22 mm
Weight.....	40 g

**Hereby, SATEL sp. z o.o. declares that the radio equipment type ASW-210 is in compliance with Directive 2014/53/EU. The full text of the EU declaration of conformity is available at the following internet address: [www.satel.pl/ce](http://www.satel.pl/ce)**

### 10.30 Smart Keyfob (APT-210)

Operating frequency band.....	868.0 MHz ÷ 868.6 MHz
Radio communication range (in open area) .....	up to 1300 m
Battery.....	CR 2032 3 V
Low battery voltage threshold .....	2.6 V
Environmental class according to EN 50130-5 .....	II
Operating temperature range.....	-10°C...+55°C
Maximum humidity .....	93±3%
Dimensions .....	37 x 66 x 14 mm
Weight.....	25 g

**Hereby, SATEL sp. z o.o. declares that the radio equipment type APT-210 is in compliance with Directive 2014/53/EU. The full text of the EU declaration of conformity is available at the following internet address: [www.satel.pl/ce](http://www.satel.pl/ce)**

### 10.31 Smart Switch Controller (ATX-200)

Operating frequency band .....	868.0 MHz ÷ 868.6 MHz
Radio communication range (in open area) .....	up to 1700 m
Battery .....	CR14250 3 V
Battery life .....	up to 3 years
Standby current consumption .....	7 µA
Low battery voltage threshold .....	2.75 V
Complied with standards .....	EN 50130-4, EN 50130-5
Environmental class according to EN50130-5 .....	II
Operating temperature range .....	-10°C...+55°C
Maximum humidity .....	93±3%
Dimensions .....	47 x 47 x 22 mm
Weight .....	40 g

**Hereby, SATEL sp. z o.o. declares that the radio equipment type ATX-200 is in compliance with Directive 2014/53/EU. The full text of the EU declaration of conformity is available at the following internet address: [www.satel.pl/ce](http://www.satel.pl/ce)**

### 10.32 Smart Button (APB-210)

Operating frequency band .....	868.0 MHz ÷ 868.6 MHz
Radio communication range (in open area) .....	up to 1300 m
Battery .....	CR2032 3 V
Battery life .....	up to 3 years
Standby current consumption .....	5 µA
Low battery voltage threshold .....	2.6 V
Environmental class according to EN 50130-5 .....	II
Operating temperature range .....	-10°C...+55°C
Maximum humidity .....	93±3%
Dimensions .....	ø50 x 13 mm
Weight .....	17 g

**Hereby, SATEL sp. z o.o. declares that the radio equipment type APB-210 is in compliance with Directive 2014/53/EU. The full text of the EU declaration of conformity is available at the following internet address: [www.satel.pl/ce](http://www.satel.pl/ce)**

### 10.33 Smart Repeater (ARU-200)

Operating frequency band .....	868.0 MHz ÷ 868.6 MHz
--------------------------------	-----------------------

Radio communication range (in open area) .....	up to 2000 m
Supply voltage .....	230 VAC, 50 Hz
Standby current consumption .....	8 mA
Maximum current consumption .....	15 mA
Battery (lithium-ion) .....	3.7 V / 1800 mAh
Environmental class according to EN 50130-5 .....	II
Operating temperature range .....	-10°C...+55°C
Maximum humidity .....	93±3%
Electronics board dimensions .....	87 x 104 mm
Enclosure dimensions .....	126 x 158 x 32 mm
Weight .....	265 g

**Hereby, SATEL sp. z o.o. declares that the radio equipment type ARU-200 is in compliance with Directive 2014/53/EU. The full text of the EU declaration of conformity is available at the following internet address: [www.satel.pl/ce](http://www.satel.pl/ce)**