

*perfecta*

Alarm control panel

# PERFECTA 64 M

Firmware version 2.04

EN

CE



QUICK INSTALLATION GUIDE

perfecta\_64\_M\_sii\_en 06/25

**Satel**®

SATEL sp. z o.o. • ul. Budowlanych 66 • 80-298 Gdańsk • POLAND  
tel. +48 58 320 94 00  
[www.satel.pl](http://www.satel.pl)

## IMPORTANT

Full manual is available on [www.satel.pl](http://www.satel.pl). Scan the QR code to go to our website and download the manual.



The security alarm system should be installed by qualified personnel.

Prior to installation, please read carefully this manual.

Changes, modifications or repairs not authorized by the manufacturer shall void your rights under the warranty.

SATEL aims to continually improve the quality of its products, which may result in changes in their technical specifications and software. Current information about the changes being introduced is available on our website.

Please visit us at:  
<https://support.satel.pl>

Hereby, SATEL sp. z o.o. declares that the radio equipment type PERFECTA 64 M is in compliance with Directive 2014/53/EU. The full text of the EU declaration of conformity is available at the following internet address: [www.satel.pl/ce](http://www.satel.pl/ce)

### Signs in this manual



Caution – information on the safety of users, devices, etc.



Note – suggestion or additional information.

## CONTENTS

1. Installation in short.....	2
2. Installing the control panel.....	2
2.1 Description of the mainboard .....	3
3. Installing the MICRA wireless system module.....	4
4. Connecting devices to the communication bus .....	5
4.1 Setting the device address.....	5
4.2 Connecting the keypads.....	6
4.2.1 Installing the PRF-LCD keypad .....	6
4.3 Connecting the Ethernet communication module.....	7
4.4 Connecting the ABAX 2 wireless system controller .....	7
4.5 Connecting the 433 MHz keyfobs receiver expansion module.....	8
4.6 Connecting the hardwired zone expanders.....	9
4.7 Connecting the hardwired output expanders.....	9
4.8 Connecting the proximity card arm/disarm devices.....	10
5. Connecting detectors and other devices to the zones .....	11
6. Connecting the sirens.....	12
7. Connecting the microphone.....	12
8. Connecting the power and starting the control panel .....	12
8.1 Main power source.....	12
8.2 Backup power source.....	13
8.3 Control panel power-up / start-up procedure.....	13
8.4 Starting the service mode .....	14
8.5 Emergency procedure of the control panel start-up .....	14
8.6 First steps after starting-up the control panel .....	14
8.6.1 Control panel with wired keypads .....	14
8.6.2 Control panel without wired keypads .....	14
9. Programming addresses for the hardwired keypads .....	14
9.1 Programming the address by means of the service function.....	15
9.2 Programming the address without entering the service mode .....	15
10. Identifying devices .....	15
10.1 Identifying devices by means of the keypad.....	15
10.2 Identifying devices by means of the PERFECTA SOFT program.....	16
11. Installing the SIM card .....	16
12. Connecting the computer to the control panel.....	16
13. Installing ABAX 2 wireless devices.....	17
14. Installing MICRA wireless devices.....	17

The manual contains basic information on the PERFECTA 64 M control panel installation. For more information, please refer to the full installation manual available at [www.satel.pl](http://www.satel.pl).



**Disconnect power before making any electrical connections.**

## 1. Installation in short

---

### Planning the alarm system

Place the devices that you want to install in the alarm system on the site plan.

### Cabling

Run the 230 VAC power cable and the cables for connecting other devices (keypads, expansion modules, detectors and sirens) to the control panel installation place. To connect the devices, use an unshielded non-twisted cable.

### Installing the control panel

Install the control panel in the enclosure. Run the cables inside the enclosure and secure the control panel enclosure to the wall using wall plugs (anchors) and screws.

### Connecting the wires

Connect all the wires to the control panel: to the communication bus connect keypads and expansion modules, to the zones – detectors, to the outputs – sirens, to the power input – 40 VA transformer. Connect the transformer to 230 VAC power.

### Turning on the power and starting the control panel

Connect the 12 V lead-acid battery to the control panel, then turn on the AC power.

### Programming addresses for the hardwired keypads

Use the keypad to start the address programming function. If there is only one hardwired keypad in the system or only wireless keypads are to be used, you can skip this step.

### Identifying devices connected to the control panel

Use the keypad or the PERFECTA SOFT program to identify the devices connected to the communication bus or the communication connector (PERFECTA-RF).

### Installing the SIM card

If the SIM card requires entering the PIN code, first program the PIN code in the control panel using the keypad or the PERFECTA SOFT program. You can install one or two nano-SIM cards in the control panel.

### Installing wireless devices

Wireless devices can be installed if the ACU-220 / ACU-280 controller (for ABAX 2 wireless devices) or the PERFECTA-RF module (for MICRA wireless devices) is connected to the control panel.

### Programming the alarm system

Use the keypad or the PERFECTA SOFT program to configure the alarm system settings.

### Testing the alarm system

Test the system to make sure that all devices and functions operate correctly. You will find the system testing functions in the keypad user menu.

## 2. Installing the control panel

---



**The control panel mainboard contains electronic components sensitive to electric charges.**

**Before connecting the mainboard to power source (battery, alternating voltage from transformer), you must first complete all the installation work with hardwired devices (connection of keypads, expansion modules, detectors etc.).**

The control panel should be installed indoors, in spaces with normal air humidity. A 230 VAC power circuit with protective grounding must be available at the installation place. The control panel must be protected against unauthorized access. It is recommended to install the control panel in a plastic enclosure.



*Do not install the control panel in a metal enclosure if the PERFECTA-RF module is to be used or another radio device is to be installed in the control panel enclosure.*

## 2.1 Description of the mainboard

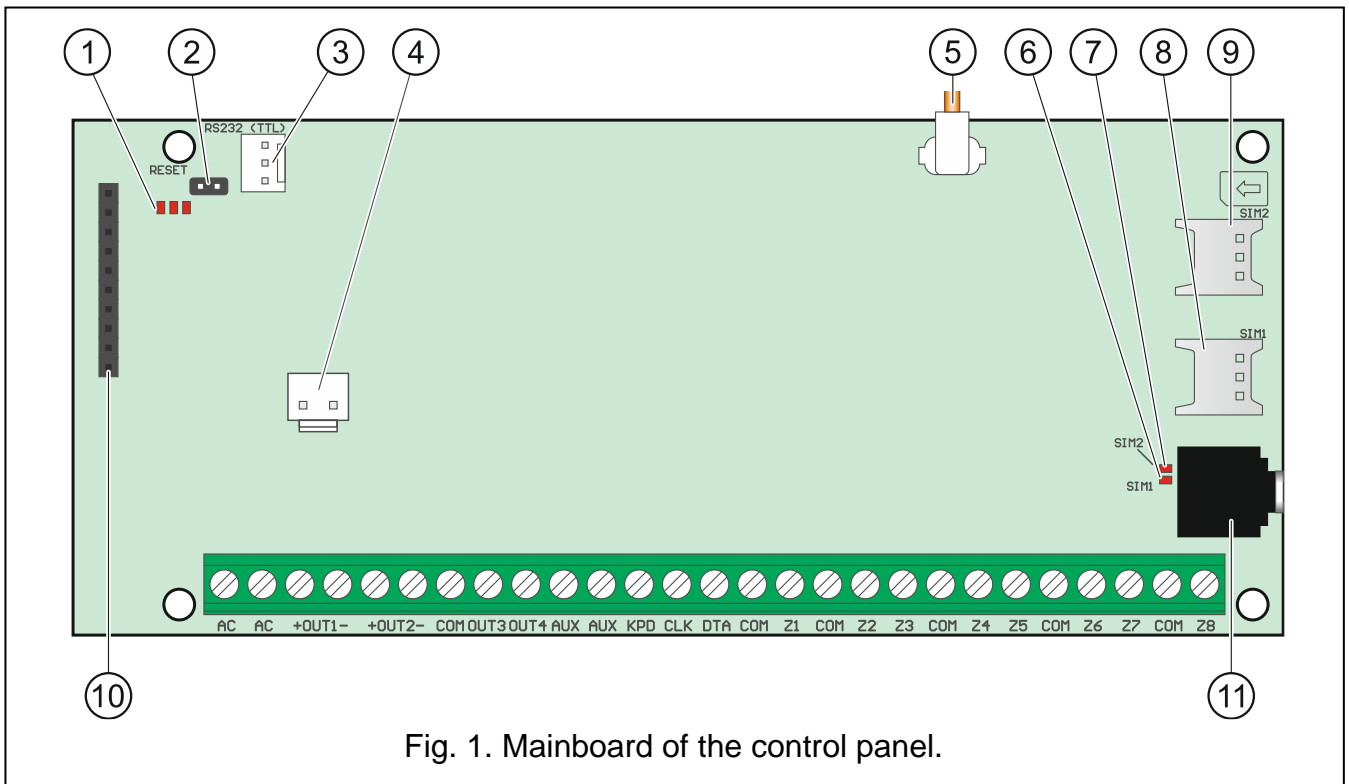

Fig. 1. Mainboard of the control panel.

- ① LED indicators:  
left – ON when the listen-in function is in use.  
center – ON when the battery is being tested.  
right – ON when the cellular communicator is on.
- ② RESET pins for emergency starting the control panel (see: “Emergency procedure of the control panel start-up” p. 14).
- ③ RS-232 (TTL) port.
- ④ connector for battery connection wires. The wires are included in the set (Fig. 2).
- ⑤ cable terminated with an antenna connector. If the control panel is installed in a plastic enclosure, you can use an antenna that can be installed inside the enclosure. If the control panel is installed in a metal enclosure, use an antenna that can be installed on the enclosure or at a certain distance from the enclosure.
- ⑥ SIM1 LED. The LED is on, when the card installed in the SIM 1 slot is active.
- ⑦ SIM2 LED. The LED is on, when the card installed in the SIM 2 slot is active.

**i** | The SIM1 or SIM2 LED is on even if no card is installed.

⑧ SIM1 slot in which the first SIM card is to be installed.

⑨ SIM2 slot in which the second SIM card is to be installed.

**i** | Inserting the SIM card into its slot before programming the card PIN code in the control panel is not recommended.

⑩ communication connector for connecting the PERFECTA-RF module.

⑪ mini-jack socket for connecting microphone.

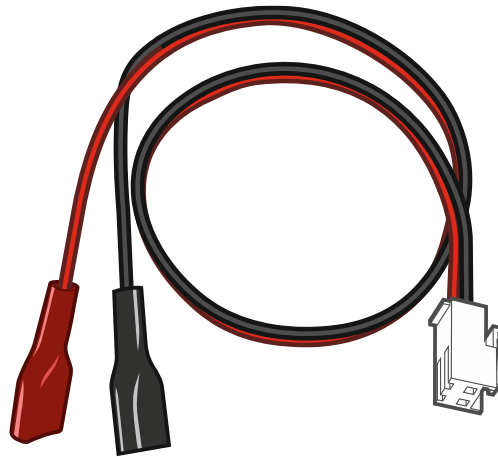

Fig. 2. Battery connection wires (red +, black -).

### Description of terminals

<b>AC</b>	- power input (18 VAC).
<b>+OUT1-, +OUT2-</b>	- programmable high-current outputs. +12 VDC voltage is always present at the “+” terminal. The “-” terminal is either shorted to or disconnected from the common ground, depending on the output status (active/inactive) and polarity.
<b>OUT3, OUT4</b>	- programmable low-current outputs, OC type (disconnected from common ground / shorted to common ground).
<b>COM</b>	- common ground.
<b>AUX</b>	- +12 VDC power output.
<b>KPD</b>	- +12 VDC power output.
<b>DTA</b>	- communication bus data.
<b>CLK</b>	- communication bus clock.
<b>Z1...Z8</b>	- zones.

## 3. Installing the MICRA wireless system module

**i** | If the PERFECTA-RF module is to be used, do not install the ACU-220 / ACU-280 controller or the INT-RX-S expander. These devices cannot be used simultaneously.

Install the PERFECTA-RF module in the slot on the electronics board as shown in Figure 3.

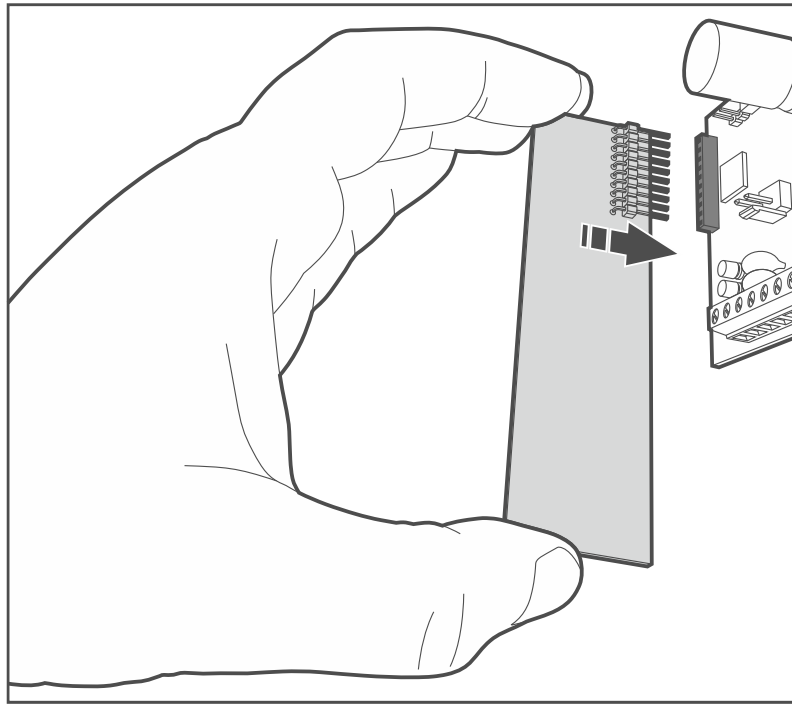

Fig. 3. Installing the PERFECTA-RF module.

## 4. Connecting devices to the communication bus



*The bus wires must be run in one cable.*

*The distance between the device and the control panel may be up to 600 m.*

*The device can be powered directly from the control panel, if the distance to the control panel does not exceed 300 m. Where the distance is greater, another power source must be provided for the device (additional power supply).*

### 4.1 Setting the device address

Setting of a suitable address is required for most devices connected to the communication bus. Two devices must not share the same address (otherwise their identification will be impossible). For most devices, use the DIP-switches to set the address. The switches have numbers assigned to them. In the OFF position, the number is 0. The numbers assigned to the switches in ON position are presented in the Table 1. The sum of these numbers is the address set.

Switch (ON position)	1	2	3	4	5
Number	1	2	4	8	16

Table 1.

For information on the requirements related to address setting, please refer to the sections describing how specific devices are to be connected.

## 4.2 Connecting the keypads

The control panel supports up to 4 keypads. These can be either wired or wireless keypads (the wireless ones can only be installed after starting the control panel). Addresses of the keypads must be set within the range from 0 to 3 (see “Programming addresses for the hardwired keypads” p. 14).

### 4.2.1 Installing the PRF-LCD keypad

The keypad is designed for indoor installation. The place of installation should be readily accessible to the system users.

1. Open the keypad enclosure (Fig. 4).

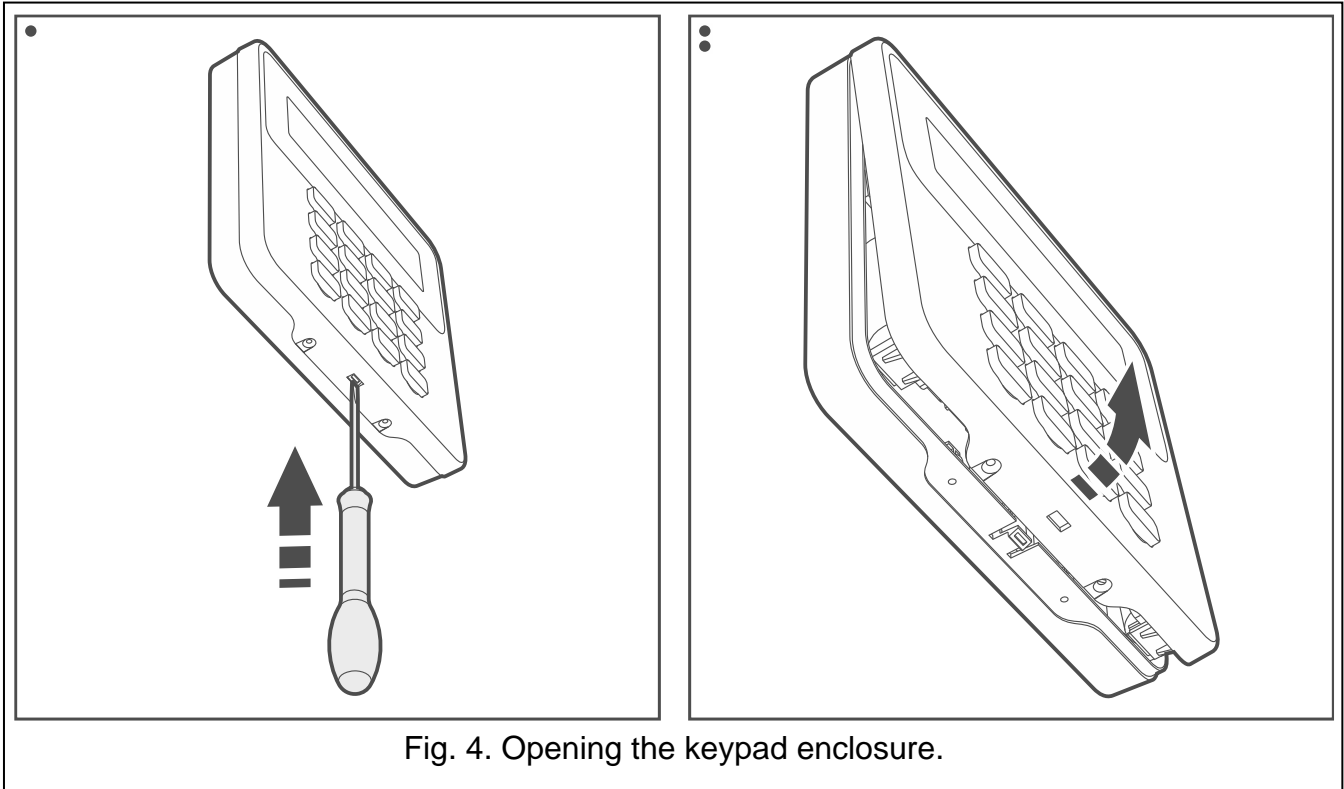
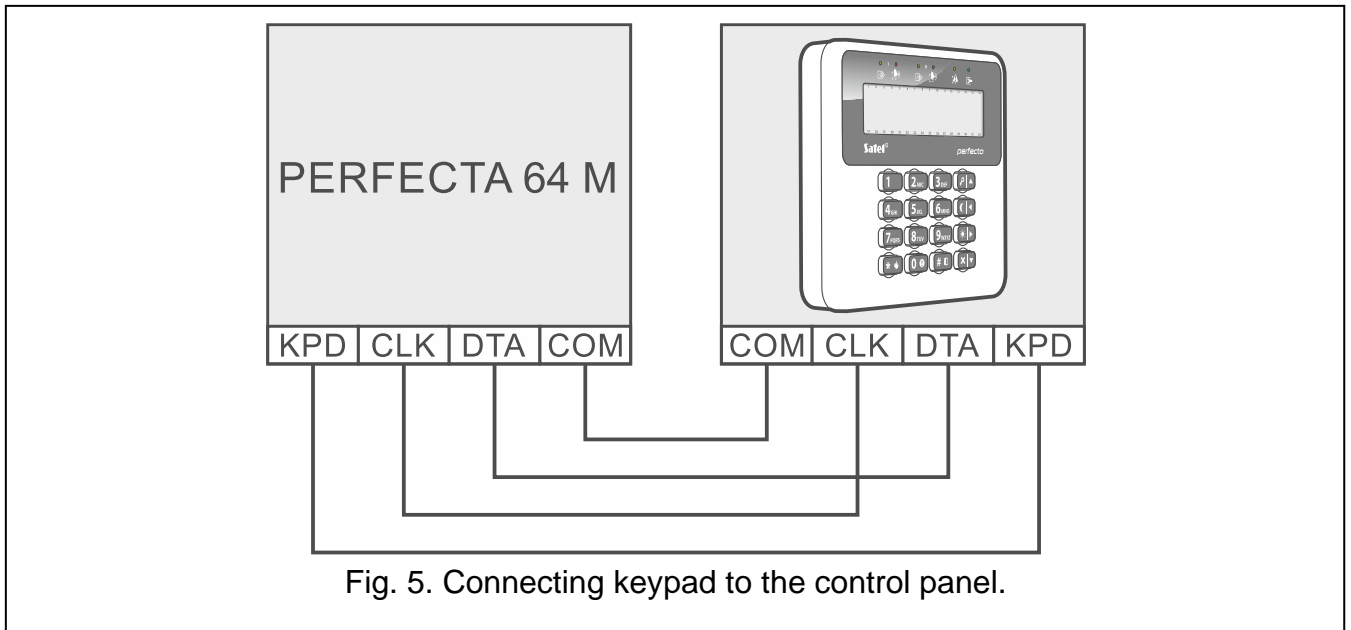

Fig. 4. Opening the keypad enclosure.

2. Place the enclosure base against the wall and mark location of the mounting holes.
3. Drill the holes in the wall for wall plugs (anchors).
4. Run wires through the opening in the enclosure base.
5. Using wall plugs (anchors) and screws, secure the enclosure base to the wall. Select wall plugs specifically intended for the mounting surface (different for concrete or brick wall, different for plaster wall, etc.).
6. Screw the wires to the keypad terminals (Fig. 5).
7. Put the cover on the catches and snap the enclosure shut.
8. Lock the cover with screws.



### 4.3 Connecting the Ethernet communication module

You can connect one ETHM-1 Plus module to the control panel. Set address 6 (06h) in the module.

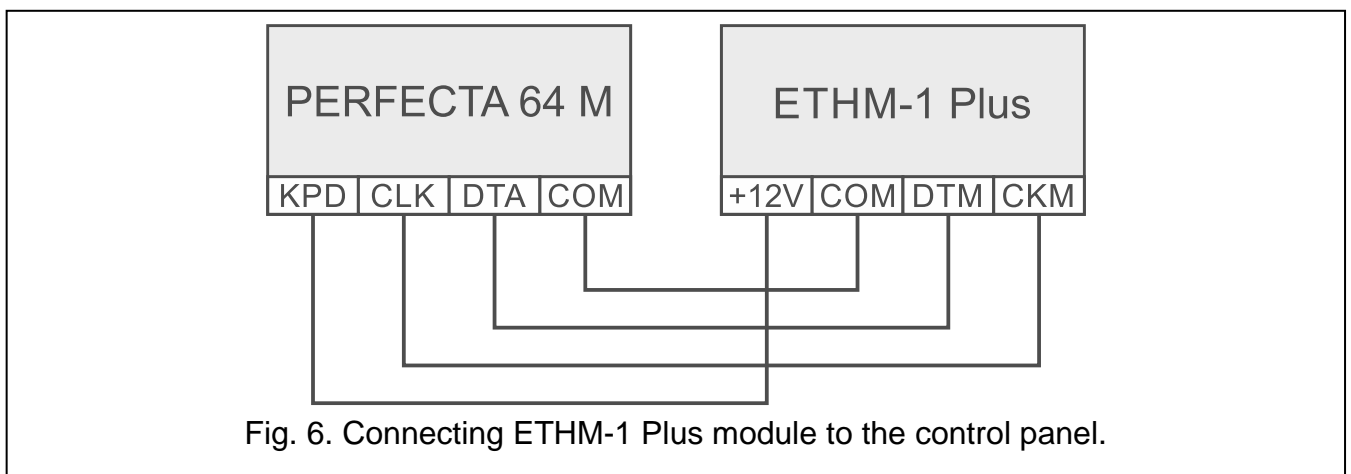

If the alarm system is to be programmed or operated via Ethernet, connect the control panel RS-232 (TTL) port to the module RS-232 port using the RS232-RSTTL converter.

### 4.4 Connecting the ABAX 2 wireless system controller



*If the ACU-220 / ACU-280 controller is to be used, do not install the PERFECTA-RF module or the INT-RX-S expander. These devices cannot be used simultaneously.*

You can connect one ABAX 2 controller to the control panel.

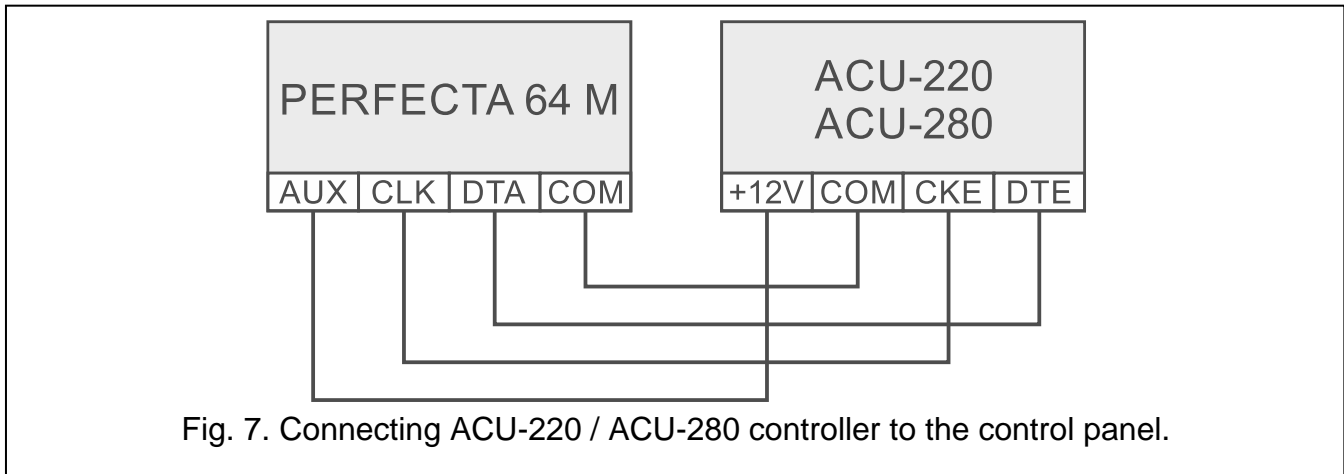

Fig. 7. Connecting ACU-220 / ACU-280 controller to the control panel.

Use the controller DIP-switches to select the correct operating mode:

- set switch 9 in OFF position,
- set switch 10 in ON position,
- you can set the remaining switches in any position (in the ACU-220 controller, switch 8 is used to select the transmitting antenna).

After devices have been identified (see: p. 15), the controller receives address 8. After wireless devices have been registered to the controller, the controller can occupy the following addresses (up to 6).



*The addresses to be occupied by the ABAX 2 controller cannot be used by the hardwired zone expanders.*

*Data of the wireless keypads, wireless devices and keyfobs are stored in the controller. If you connect a controller with registered devices to the control panel:*

- *keypads will be added to the alarm system,*
- *wireless devices will be assigned to the alarm system zones / outputs,*
- *keyfobs will be assigned to users.*

*This may cause problems (e.g. identification may be impossible due to conflicting addresses). For this reason, it is recommended not to connect a controller with registered devices to the control panel.*

#### 4.5 Connecting the 433 MHz keyfobs receiver expansion module



*If the INT-RX-S expander is to be used, do not install the ACU-220 / ACU-280 controller or the PERFECTA-RF module. These devices cannot be used simultaneously.*

You can connect one 433 MHz keyfobs receiver expansion module to the control panel. Set address 7 (07h) in the module. See: "Setting the device address" (p. 5).

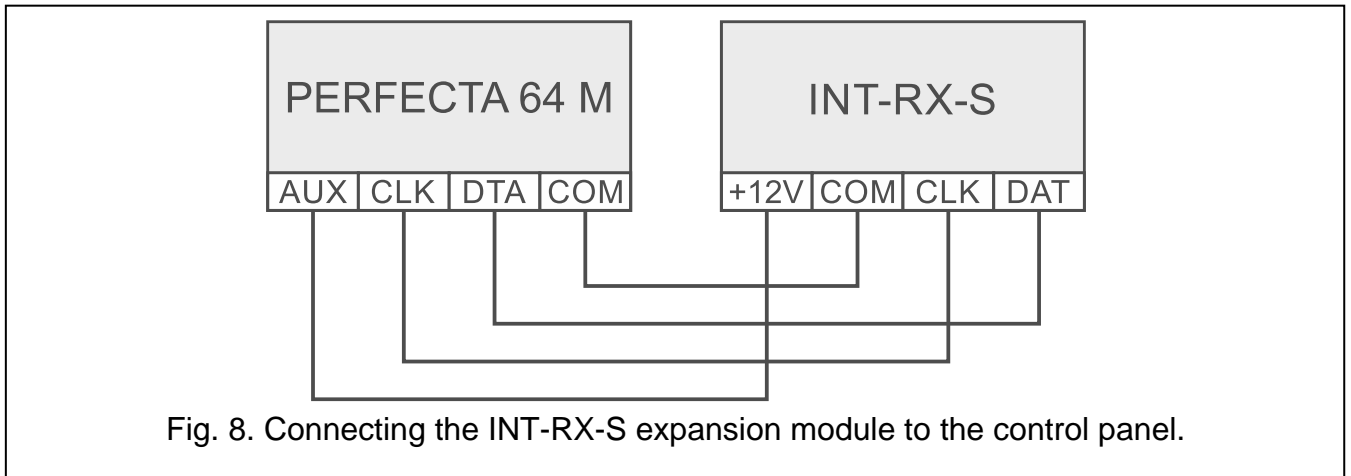

#### 4.6 Connecting the hardwired zone expanders

You can connect up to 7 zone expanders to the control panel.

In the expanders, set addresses in the range from 8 (8h) to 14 (0Eh). See: “Setting the device address” (p. 5).



*If the ABAX 2 controller is to be used in the alarm system, consider the number of addresses the controller will occupy after the wireless devices have been registered to the controller. Do not set an address in the expander that can be assigned to the ABAX 2 controller after the wireless devices have been registered.*

The DIP-switch 10 must be set in the OFF position.

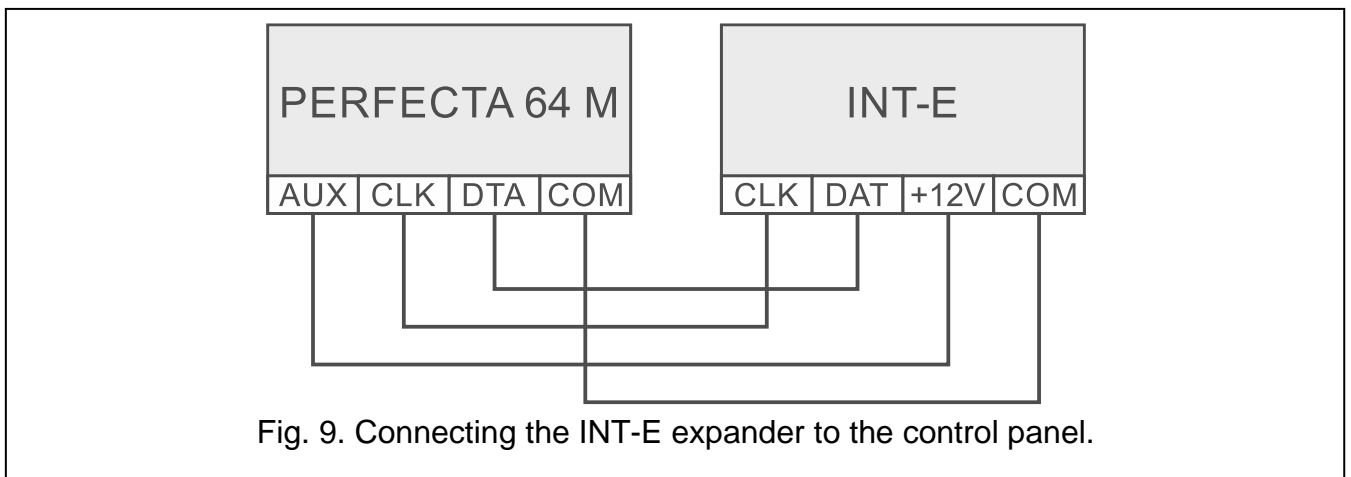

The INT-E expander will be identified as:

**INT-E** – power supply by SATEL is not connected to the expander connector,

**INT-EPS** – power supply by SATEL is connected to the expander connector.

#### 4.7 Connecting the hardwired output expanders

You can connect up to 7 output expanders to the control panel.

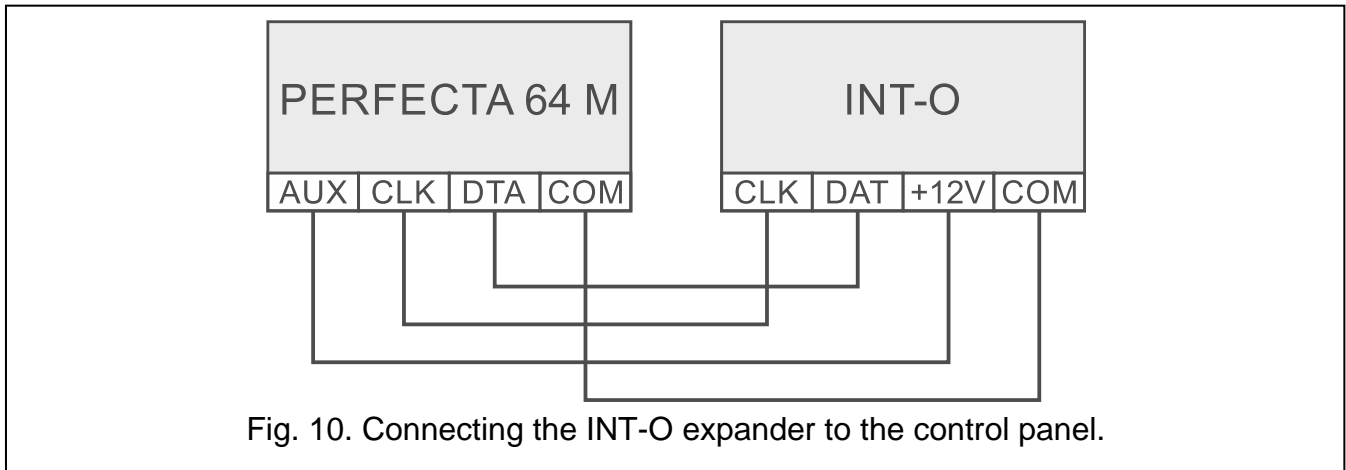

Fig. 10. Connecting the INT-O expander to the control panel.

In the expanders, set addresses in the range from 15 (0Fh) to 21 (15h). See: “Setting the device address” (p. 5). Additionally, in the INT-ORS expanders:

10-position DIP-switch: set switch 6 in OFF position and switch 10 in ON position,

6-position DIP-switch: set switch 6 in OFF position.

The INT-O / INT-ORS expander will be identified as:

**INT-O** – power supply by SATEL is not connected to the expander connector,

**INT-OPS** – power supply by SATEL is connected to the expander connector.

#### 4.8 Connecting the proximity card arm/disarm devices

You can connect up to 8 proximity card arm/disarm devices to the control panel. In the devices, set addresses in the range from 22 (16h) to 29 (1Dh). See: “Setting the device address” (p. 5).

The INT-CR device will be identified as INT-IT-2.

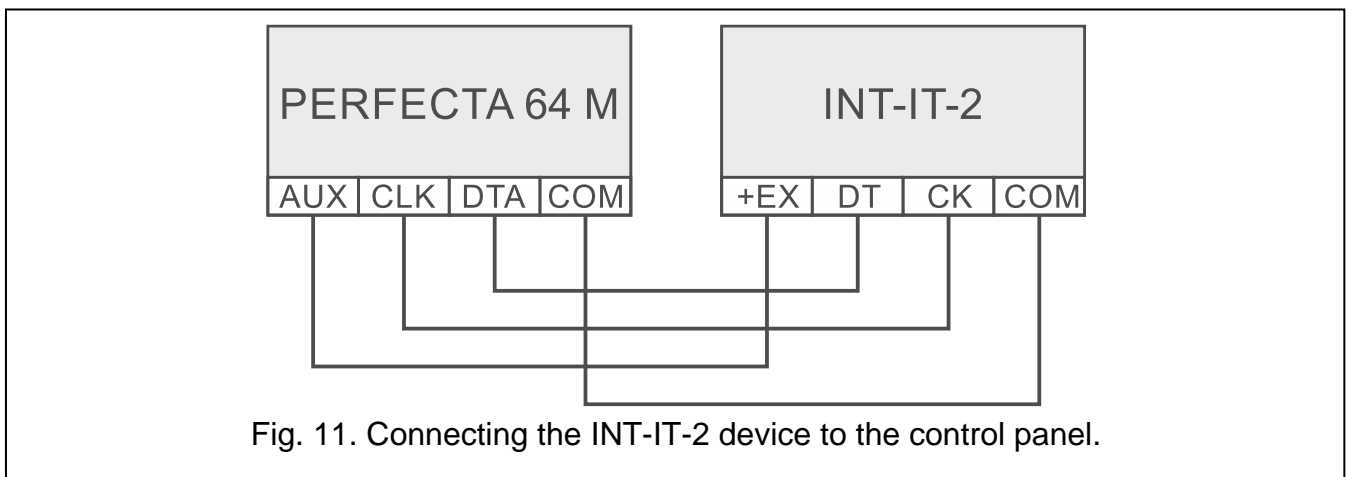

Fig. 11. Connecting the INT-IT-2 device to the control panel.





INT-CR wire	Description	Control panel terminal
 brown	power	AUX / KPD
 white	common ground	COM
 gray	clock	CLK
 green	data	DTA

Table 4. Connecting the INT-CR device to the control panel.

## 5. Connecting detectors and other devices to the zones

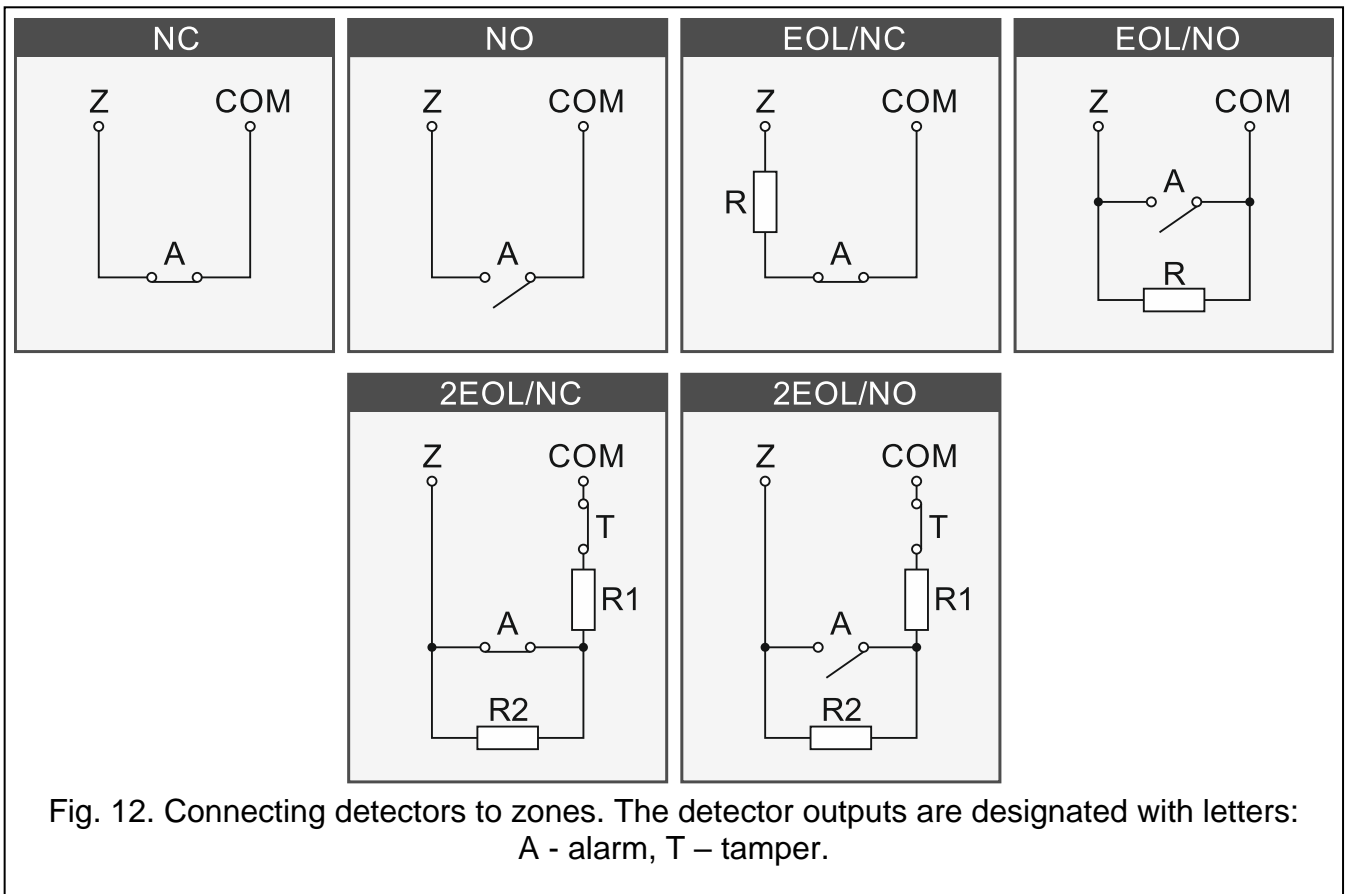

Zones of the control panel support the following wiring configurations:

**NC** – for connecting a detector with NC (normally closed) alarm output. Opening the circuit will trigger an alarm.

**NO** – for connecting a detector with NO (normally open) alarm output. Closing the circuit will trigger an alarm.

**EOL** – for connecting a detector with NC or NO alarm outputs. An EOL resistor must be used in the circuit. Alarm will be triggered by closing or opening the circuit.

**2EOL/NC** – for connecting a detector with NC alarm output and tamper output. Two EOL resistors must be used in the circuit. The zone can distinguish between 3 states: normal, alarm and tamper.

**2EOL/NO** – wiring configuration similar as 2EOL/NC, but for detectors with the NO alarm output.

**Roller** – for connecting a roller shutter detector.

**Vibration** – for connecting a shock detector. You can also connect to the zone a detector with NC alarm output (e.g. shock detector and magnetic contact can be connected in series).

### End-of-line resistors

The value of EOL resistors is programmable. According to the factory settings, depending on the wiring type:

- EOL – use one 2.2 k $\Omega$  resistor,
- 2EOL – use two 1.1 k $\Omega$  resistors.

## 6. Connecting the sirens



*It is recommended that the control panel be started without connected sirens. This will prevent accidental triggering of the signaling after the control panel is started.*

Depending on the siren type:

- sirens without own power source (e.g. SP-500, SP-4001, SP-4003, SPL-2010, SPW-100, SPW-210, SPW-220) – high-current outputs are to be used to trigger the signaling,
- sirens with own power source (e.g. SP-4002, SP-4004, SP-4006, SP-6500, SPLZ-1011, SD-3001, SD-6000) – it is recommended to use low-current outputs to trigger the signaling, and high-current ones – to supply power.

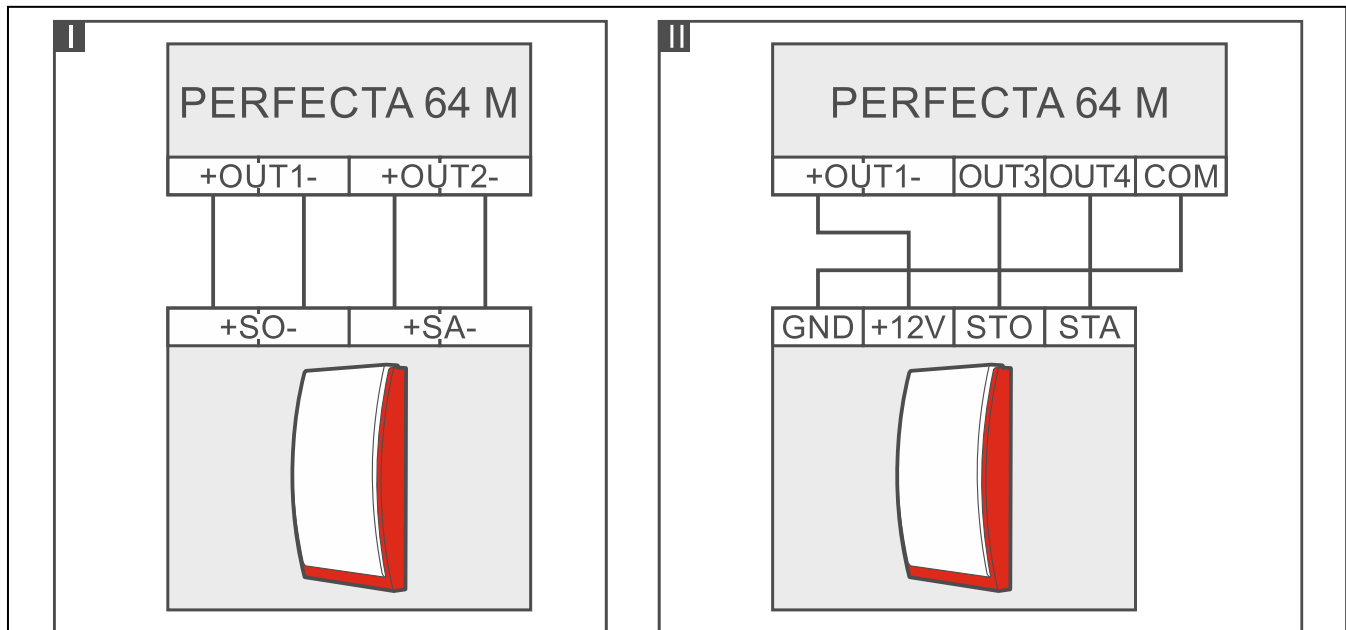

Fig. 13. Connecting sirens to the control panel outputs. I – siren without own power source. II - siren with own power source.

## 7. Connecting the microphone

SATEL offers the MIC-1 microphone, which can be connected to the mini-jack socket on the control panel. If you decide to use another type, it should be an electret microphone, e.g. a typical computer microphone.

When selecting the microphone installation place, bear in mind that curtains, drapes, upholstery, acoustic tiles, etc. absorb sound and, as a result, make it difficult, if not impossible, to use the listen-in feature. It is not advisable to install the terminal in the vicinity of equipment which generates noise during operation (e.g. fans, air conditioners, refrigerators).

## 8. Connecting the power and starting the control panel



**Do not connect power until all installation operations are completed.**

### 8.1 Main power source

The control panel requires 18 VAC ( $\pm 10\%$ ) power. It is recommended that a transformer with 40 VA rating be used.

The transformer should be permanently connected to the 230 VAC mains power. The electrical circuit to which the transformer is to be connected must have suitable protection (2-pole switch disconnecter and/or 16 A slow-blow fuse). Instruct the owner / user of the system on how to disconnect the transformer from the mains supply (e.g. indicate the fuse or circuit breaker protecting the transformer supply circuit).



**Do not connect two devices with power supply to one-section transformer.**

**Before connecting transformer to a circuit from which it will be powered, make sure the circuit is de-energized.**

## 8.2 Backup power source

---

For a backup power source, use a 12 V sealed lead-acid battery or other 12 V battery with similar charging characteristics. The battery capacity must be selected to match current consumption in the system. If the system is to meet the requirements of the EN 50131 standard for Grade 2, the battery must ensure operation of the system without mains power for 12 hours.

If the battery voltage drops below 11 V for longer than 12 minutes (3 battery tests), the control panel will indicate battery failure. When the voltage goes down to approx. 10.5 V, the battery will be disconnected.



**Do not connect deeply discharged battery to the control panel (with voltage across unloaded terminals below 11 V). The battery should be precharged with a proper charger.**

**The used batteries must not be discarded, but should be disposed of in accordance with the existing rules for environment protection.**

## 8.3 Control panel power-up / start-up procedure

---

1. De-energize the 230 VAC circuit to which the transformer is to be connected.
2. Connect the 230 VAC wires to the terminals of transformer primary winding.
3. Connect the terminals of transformer secondary winding to the control panel AC terminals. To make the connection, use flexible wires with a cross-section of 0.5-0.75 mm<sup>2</sup>.
4. Connect the battery wires (Fig. 2) to the connector on the electronics board.
5. Connect the battery to the dedicated wires (positive terminal to red wire, negative terminal to black wire). If the battery has screw-type cable lugs, use adapters delivered with the control panel (do not cut off the battery cable lugs). **The control panel will not start after connecting the battery alone.**
6. Turn on 230 VAC power in the circuit to which the transformer is connected. The control panel will start operating.



*The above mentioned power-up sequence (first the battery, then the 230 VAC mains) will ensure proper operation of the power supply and the electronic protection circuits, thus preventing damage to the alarm system components caused by installation mistakes, if any.*

*If it is necessary to de-energize the control panel, turn off the main power (AC) first, and the backup power (battery) afterwards. Observe the above described procedure when reconnecting the power.*





## 8.4 Starting the service mode

---

If, after starting the alarm control panel, you want to perform any operations that do not require power-off (e.g. to adjust sensitivity in wired detectors), enter the service mode.



**When the control panel is running in service mode, tamper alarms are not generated.**

1. Enter the **service code** (by default: 12345) and press .
2. User menu will be displayed.
3. Press .
4. When the  cursor shows the SERVICE MODE function, press .
5. Service mode menu will be displayed (the  cursor will show the END SM function).

## 8.5 Emergency procedure of the control panel start-up

---

If the control panel fails to start properly, keypads are not supported, codes are not accepted by the control panel etc., despite all connections having been made correctly, follow the steps below:

1. Power off the control panel (disconnect AC mains first, and the battery next).
2. Place a jumper across the RESET pins.
3. Power up the control panel (first connect the battery and then the AC power).
4. Wait a few seconds (until LEDs next to the RESET pins stop flashing) and remove the jumper from the RESET pins. The control panel will enter the service mode. The service mode menu will be displayed on the wired keypad with the lowest address.



*If there is no wired keypad in the alarm system or there is no communication with the wired keypads (e.g. when the communication bus is shorted), you can get access to the service mode menu from the wireless keypad with the lowest address. Press any key on this keypad within 30 seconds of removing jumper from the RESET pins.*

## 8.6 First steps after starting-up the control panel

---

### 8.6.1 Control panel with wired keypads

1. Set correct, individual addresses in the wired keypads.
2. Run the device identification function.

### 8.6.2 Control panel without wired keypads

1. Connect computer to alarm control panel.
2. Add wireless keypads in the PERFECTA SOFT program.
3. Run the device identification function.

## 9. Programming addresses for the hardwired keypads

---

An individual address from the 0 to 3 range must be set for each keypad. By default, address 0 is preset for all wired keypads.

Below, it is described how to program the address in the PRF-LCD keypads. The instructions for other wired keypads are described in their respective manuals.

## 9.1 Programming the address by means of the service function



*The address programming function can be started from either a wired or wireless keypad, but it will only allow setting addresses in the wired keypads.*

1. Start the service mode (see: “Starting the service mode” p. 14).
2. Press successively **2<sub>ABC</sub>** **0** **#** **0** to run the 20.KPD.ADDRESS function.
3. Information on the current address and permissible address range will be displayed on all wired keypads (see Fig. 14).

The image shows a rectangular LCD display with a pixelated font. The text on the screen is arranged in two lines: the first line reads "This LCD address" and the second line reads "(n: 0-3): \_". The underscore indicates a blank space for a digit.

Fig. 14. Programming keypad address (n = current address).

4. On the keypad the address of which you want to change, press the key whose digit corresponds to the new address.
5. Press **\* 🔥** to finish the function (the function will be finished automatically after 2 minutes since it was launched). The keypad will be restarted.

## 9.2 Programming the address without entering the service mode

This way of address programming is useful when the keypad operation is blocked and starting the service mode is impossible.

1. Power off the keypad.
2. Disconnect wires from the keypad CLK and DTA terminals.
3. Short the CLK and DTA keypad terminals.
4. Power on the keypad.
5. Information on the current address and permissible address range will be displayed on the keypad (see: Fig. 14).
6. Press the key whose digit corresponds to the new address (if you make a mistake, press **\* 🔥** to restart the keypad – current address information will be displayed again).
7. Power off the keypad.
8. Open the CLK and DTA keypad terminals.
9. Connect wires properly to the CLK and DTA keypad terminals.
10. Power on the keypad.

## 10. Identifying devices

Devices connected to the communication bus and the communication connector (PERFECTA-RF) will not be properly supported, unless they have been identified by the control panel.

### 10.1 Identifying devices by means of the keypad

1. Start the service mode (see: “Starting the service mode” p. 14).
2. Press successively **2<sub>ABC</sub>** **1** **#** **0** to run the 21.IDENTIFICAT. function.
3. “Please wait...” message will appear.

- After devices connected to the communication bus and the communication connector are identified, information on the number of such devices will be displayed.



*If information is displayed that there is a problem with a device with specific address, it means that a wrong address is set on the device (invalid for this type of device or the same address is set on at least two devices) or that the device is not supported.*

- Press **\* ↓** to quit the function.

## 10.2 Identifying devices by means of the PERFECTA SOFT program

- Click on the “Hardware” tab.
- Click on “Mainboard”.
- Click on “Detect connected modules”.
- After devices connected to the communication bus and the communication connector are identified, information on the number of such devices will be displayed.



*In the event of any problems with identification (e.g. an invalid address is set in the device), a message will be displayed to inform you about the problem.*

- Click on “READ DATA FROM PANEL”.

## 11. Installing the SIM card

Slots on the mainboard make it possible to install two nano-SIM cards.



*If the control panel is to transmit data over the cellular network, it is recommended that you use SIM cards with a dedicated tariff plan for M2M (machine-to-machine) communication.*

*If the SIM card requires entering the PIN code, program the PIN code before you install the card.*

*If you enter a wrong PIN code, a trouble will be reported. After 255 seconds the control panel will retry to use the PIN code. After the third attempt to use a wrong PIN code, the SIM card will be blocked. To unblock the card, enter the PUK code using the keypad (see: User manual).*

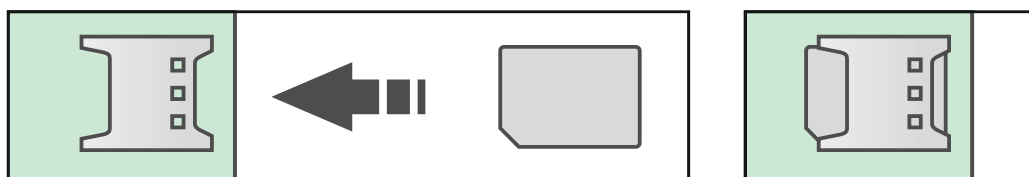

Fig. 15. Installing the nano-SIM card.

## 12. Connecting the computer to the control panel

You can connect the control panel RS-232 (TTL) port with the computer USB port. To make the connection, use the USB-RS converter offered by SATEL. Having connected the computer to the control panel, you can:

- configure the alarm system in the PERFECTA SOFT program (communication is encrypted),
- update the control panel firmware.

## 13. Installing ABAX 2 wireless devices

---

If you connected the ABAX 2 controller (ACU-220 / ACU-280) to the control panel, you can install ABAX 2 wireless devices in the alarm system. You can do it after starting the control panel and identifying the devices used in conjunction with the control panel.

Before installing a wireless device, check the level of radio signal received by the device from controller and by the controller from device at the planned installation place. You can check the radio signal level using the ARF-200 tester. It allows you to check the radio signal strength at the place of future installation without having to put the device there. The level of signal received by the device/controller may not be lower than 40%. If the radio signal level at the planned installation place is lower, select another installation place. It may be sufficient to shift the device ten or twenty centimeters. You can only install the device at the planned location after making sure that the level of the radio signal is correct. For detailed information about installation of individual devices, please refer to the manuals of the respective products.

The ABAX 2 wireless devices must be registered to the controller (only the ARF-200 tester can be supported when unregistered). You can do it in the PERFECTA SOFT program. For instructions on how to register devices to the controller, please refer to the full manual.



*Before adding a device that was previously registered to the ABAX / ABAX 2 system, you must restart it (remove the battery / power the device off for 30 seconds).*

## 14. Installing MICRA wireless devices

---

If you installed the PERFECTA-RF module on the control panel mainboard, you can install MICRA (433 MHz) wireless devices in the alarm system. You can do it after starting the control panel and identifying the devices used in conjunction with the control panel.

Before installing a wireless device, check if transmissions from the device positioned in the planned installation place reach the control panel. You can do it after you register the device to the control panel. To send a transmission, you can, for example, open the tamper switch on the device. If transmissions from the device in the expected place of installation do not reach the control panel, select another location. It may be sufficient to shift the device ten or twenty centimeters. Do not secure the device permanently until you make sure that the control panel receives transmissions from the device. For detailed information about installation of individual devices, please refer to the manuals of the respective products.

All MICRA wireless devices must be registered to the control panel. You can do it in the PERFECTA SOFT program or the LCD keypad. For instructions on how to register devices to the controller, please refer to the full manual.

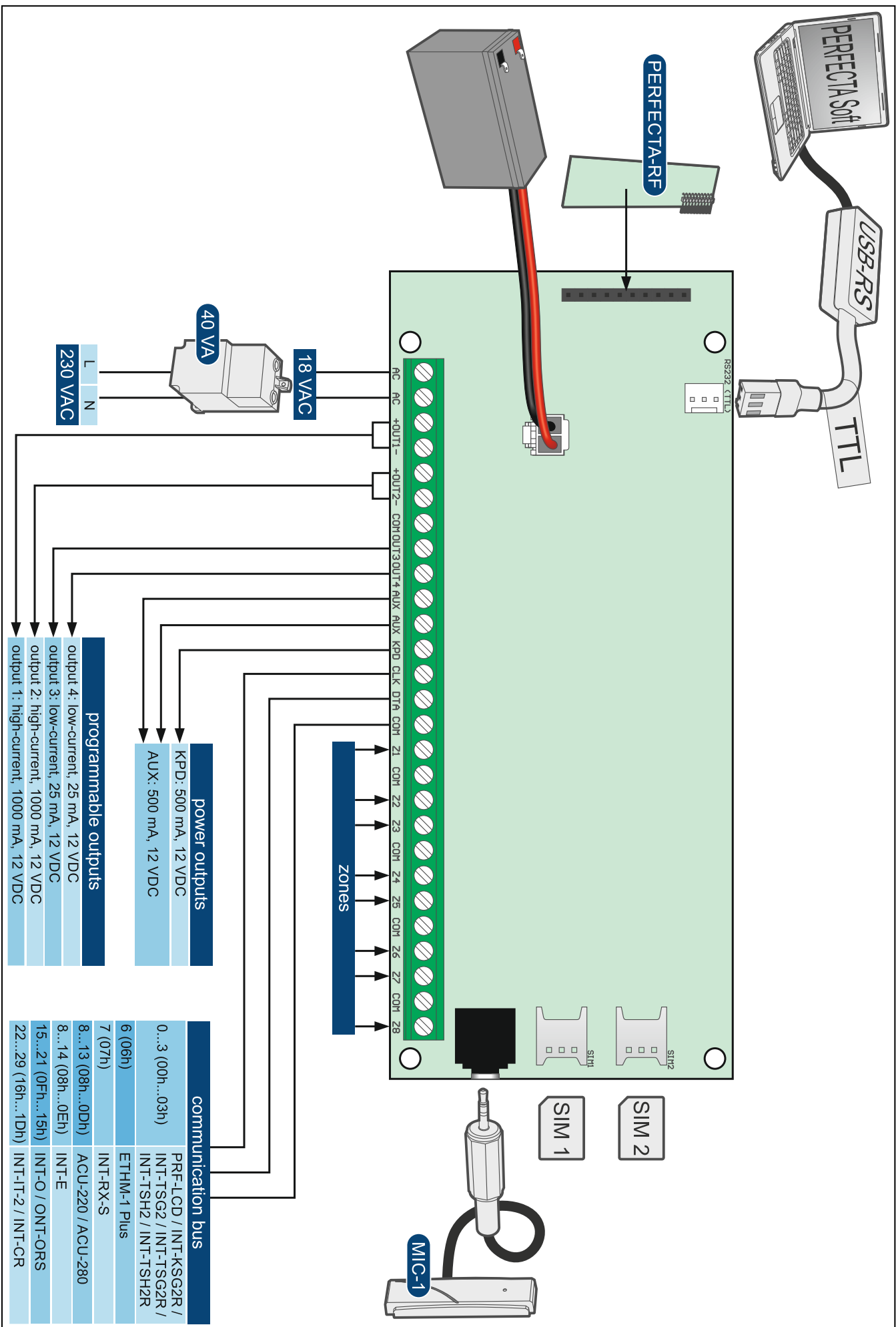

**programmable outputs**

- output 4: low-current, 25 mA, 12 VDC
- output 3: low-current, 25 mA, 12 VDC
- output 2: high-current, 1000 mA, 12 VDC
- output 1: high-current, 1000 mA, 12 VDC

**power outputs**

- KPD: 500 mA, 12 VDC
- AUX: 500 mA, 12 VDC

communication bus	
0...3 (00h...03h)	PRF-LCD / INT-KSG2R / INT-TSG2 / INT-TSG2R / INT-TSH2 / INT-TSH2R
6 (06h)	ETHM-1 Plus
7 (07h)	INT-RX-S
8...13 (08h...0Dh)	ACU-220 / ACU-280
8...14 (08h...0Eh)	INT-E
15...21 (0Fh...15h)	INT-O / ONT-ORS
22...29 (16h...1Dh)	INT-IT-2 / INT-CR