

MICRA

Wireless smoke and heat detector

MSD-300

Firmware version 2.00

EN

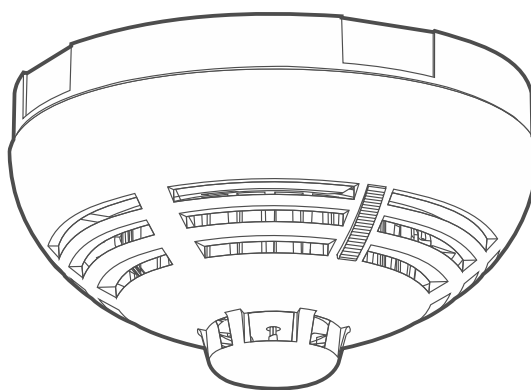

CE

msd-300_en 08/24

Satel ®

SATEL sp. z o.o. • ul. Budowlanych 66 • 80-298 Gdańsk • POLAND
tel. +48 58 320 94 00
www.satel.pl

IMPORTANT

The device should be installed by qualified personnel.

Prior to installation, please read carefully this manual in order to avoid mistakes that can lead to malfunction or even damage to the equipment.

Changes, modifications or repairs not authorized by the manufacturer shall void your rights under the warranty.

Description of symbols on the device:



The device meets the requirements of the applicable EU directives.



The device is designed for indoor installation.



The device must not be disposed of with other municipal waste. It should be disposed of in accordance with the existing rules for environment protection (the device was placed on the market after 13 August 2005).



The device meets the technical regulations of the Eurasian Customs Union.

SATEL aims to continually improve the quality of its products, which may result in changes in their technical specifications and software. The current information on the introduced modifications is available on our website.

Please visit us at:
<https://support.satel.pl>

Hereby, SATEL sp. z o.o. declares that the radio equipment type MSD-300 is in compliance with Directive 2014/53/EU. The full text of the EU declaration of conformity is available at the following internet address: www.satel.pl/ce

Signs in this manual



Caution – information on the safety of users, devices, etc.



Note – suggestion or additional information.

CONTENTS

1.	Features	2
2.	Description.....	2
	Fire alarm	2
	Tamper alarm	3
	Radio transmissions	3
	Detector test	3
	Test mode.....	3
	Detection of dirt in the optical chamber.....	3
	Battery status control.....	3
	LED indication	4
	Acoustic signaling.....	4
3.	Installation	4
	3.1 Tips for installation.....	4
	3.2 Installation	5
4.	Maintenance	7
5.	Cleaning the optical chamber	7
6.	Battery replacement.....	8
7.	Specifications	9

The MSD-300 multisensor detector can detect the early stages of fire development when there is some visible smoke and/or temperature rise. It is designed to work as a stand-alone device or within the MICRA wireless system. This manual applies to the detector with electronics version 1.2 (or newer). It is supported by:

- PERFECTA alarm control panels (WRL models),
- PERFECTA-RF module,
- VERSA-MCU controller,
- MTX-300 controller,
- MICRA alarm module (firmware version 2.02 or newer).

1. Features

- Visible smoke sensor.
- Detection of dirt in the optical chamber.
- Heat sensor.
- Encrypted radio transmissions in the 433 MHz frequency band.
- Red LED indicator.
- Built-in sounder.
- Detector test / reset button.
- Battery status control.
- Tamper protection against cover removal.

2. Description

Fire alarm

Smoke detection

The optical method is used for the detection of visible smoke. When the concentration of smoke in the optical chamber exceeds a given threshold, an alarm is generated. The smoke sensor operating parameters are modified depending on the temperature changes recorded by the heat sensor (thermistor). The detector automatically compensates for gradual changes in the optical chamber caused by deposition of dust.

Temperature detection

When the temperature exceeds 54°C or it rises too fast (see table 1), an alarm will be generated.

Air temperature rate of rise	Lower limit of response time	Upper limit of response time
1°C/min	29 min	40 min 20 s
3°C/min	7 min 13 s	13 min 40 s
5°C/min	4 min 9 s	8 min 20 s
10°C/min	1 min	4 min 20 s
20°C/min	30 s	2 min 20 s
30°C/min	20 s	1 min 40 s

Table 1. Rate-of-rise response time limits for the heat sensor.

Fire alarm signaling

The fire alarm is indicated by the LED indicator (ON) and the built-in sounder (continuous sound) for 5 minutes.

Resetting the fire alarm

Press the test / reset button (Fig. 1) to clear the alarm. The fire alarm signaling will be turned off for 5 minutes.

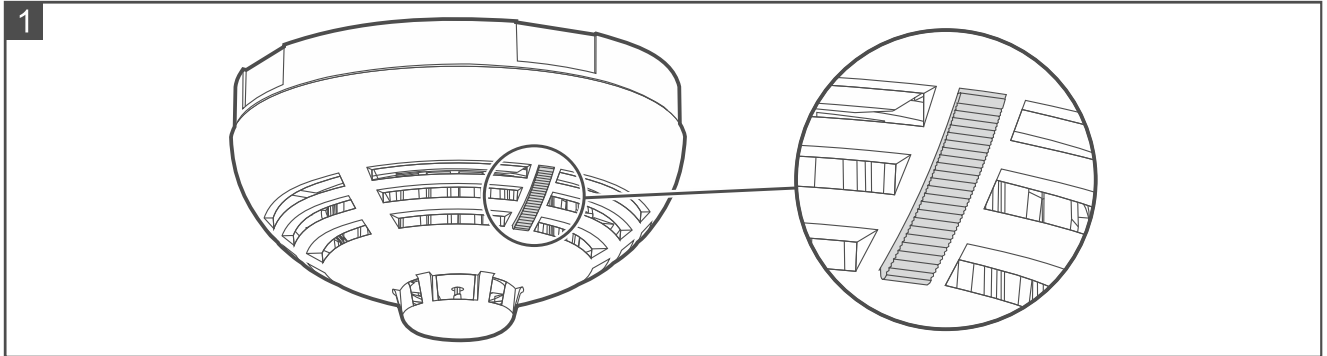

Tamper alarm

Opening the enclosure (opening the tamper switch) will generate a tamper alarm. It is indicated by the LED indicator (ON for 2 seconds).

Radio transmissions

Every 15 minutes, the detector sends information about its state (periodical transmission). Additional transmissions are sent in case of:

- fire alarm,
- fire alarm restore,
- tamper alarm,
- tamper alarm restore.

Detector test

If you want to test the detector operation, press the test / reset button (Fig. 1). You will hear a short beep. A fire alarm should be generated soon after.

Test mode

The test mode is turned on for 20 minutes after inserting the battery or opening the enclosure (tamper switch). When the detector is in the test mode, the LED indicator additionally indicates periodical transmission.

Detection of dirt in the optical chamber

The detector is monitoring the state of the optical chamber. Deposition of dust in it may lead to malfunctioning of the device. When the optical chamber requires cleaning:

- LED indicator flashes every 40 seconds,
- each radio transmission contains information about dirt in the optical chamber.

Battery status control

The detector is monitoring the battery voltage. When the battery voltage is lower than 2.75 V, i.e. the battery is low:

- the detector produces a single beep every 40 seconds,

- each radio transmission contains information about low battery.

LED indication

The LED indicator (Fig. 1) indicates:

- fire alarm – ON for 2 minutes,
- tamper alarm – ON for 2 seconds,
- dirt in the optical chamber – single flash every 40 seconds,
- periodical transmission – single flash (only in the test mode).

Acoustic signaling

Built-in sounder indicates:

- fire alarm – continuous beep sound for 2 minutes,
- low battery – single beep every 40 seconds,
- start of the detector test – single beep.

3. Installation

3.1 Tips for installation

- The detector should be installed indoors, in spaces with normal air humidity.
- Do not install the detector outdoors.
- The detector should be installed on the ceiling, as close as possible to the center of the room.
- Do not install the detector in places with high concentration of dust and/or formation and condensation of water steam.
- Do not install the detector near heaters, cookers, fans or air-conditioner outlets.
- Do not install the detector in places where there is no unobstructed movement of air (e.g. in recesses, niches, etc.).
- If the detector is to work within the wireless system, when selecting the place of installation, take into consideration the range of radio communication (so that radio transmissions from the detector can reach the receiver).
- Thick walls, metal partitions, etc. reduce the range of the radio signal.
- It is not advisable to install the detector in close vicinity of electrical systems, because it can adversely affect the range of radio signal.
- If you are using a double-sided mounting tape, remember to press it properly.

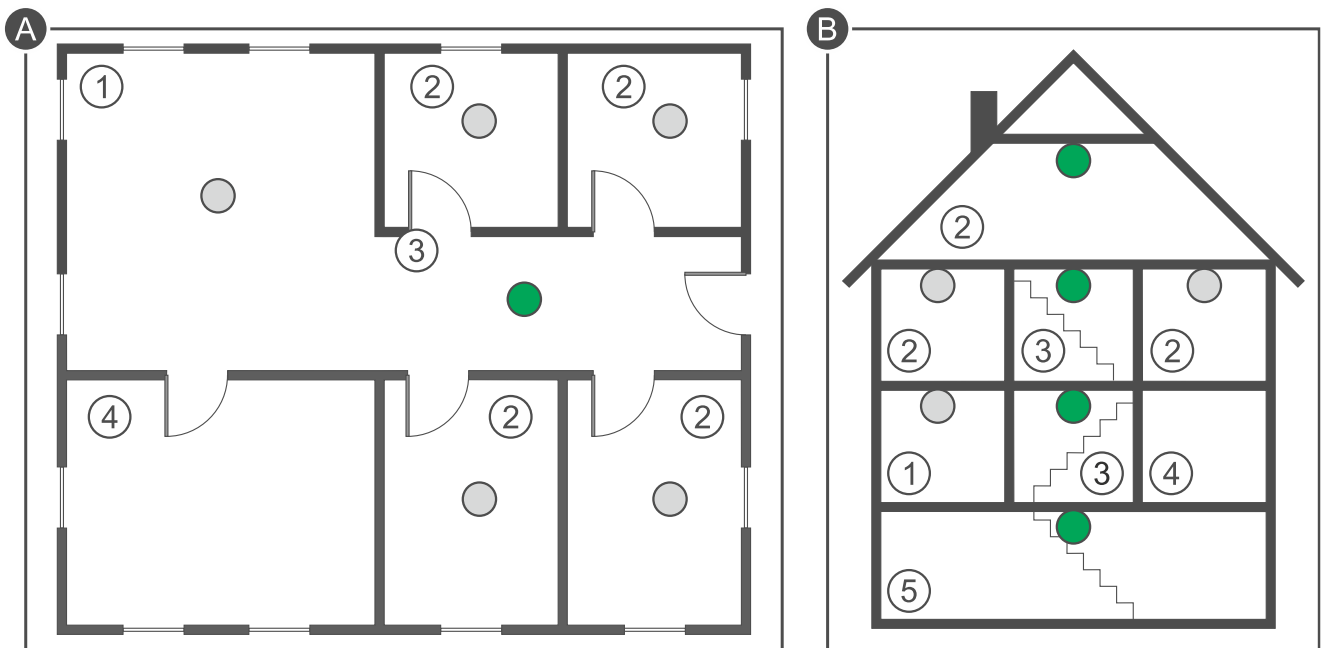

Explanations for figures A and B:

- ① living room.
- ② bedroom.
- ③ hall, lobby, etc.
- ④ kitchen.
- ⑤ basement.
- primary location for detector installation.
- additional location for detector installation.

3.2 Installation



The detector enclosure cannot be closed without the battery inserted.

There is a danger of battery explosion when using a different battery than recommended by the manufacturer, or handling the battery improperly.

Do not crush the battery, cut it or expose it to high temperatures (throw it into the fire, put it in the oven, etc.).

Do not expose the battery to very low pressure due to the risk of battery explosion or leakage of flammable liquid or gas.

Be particularly careful during installation and replacement of the battery. The manufacturer is not liable for the consequences of incorrect installation of the battery.

The following instructions describe how to install a detector that is to work within the wireless system. If the detector is to work as a stand-alone device, skip the steps 4-6.

1. Remove the plastic dust cup.
2. Turn the cover counter-clockwise (Fig. 2) and remove it (Fig. 3).

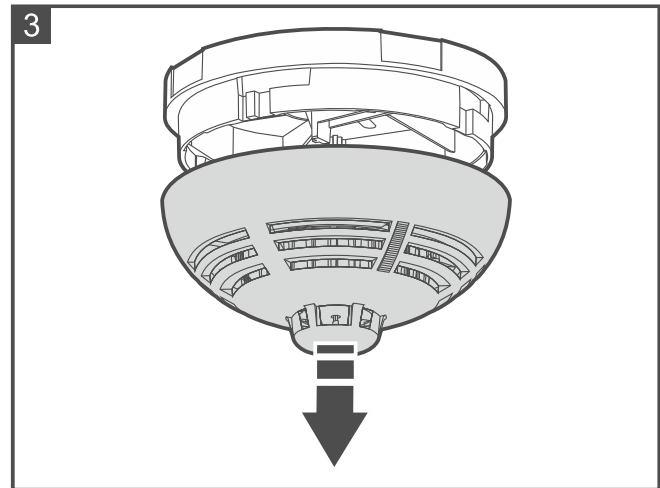
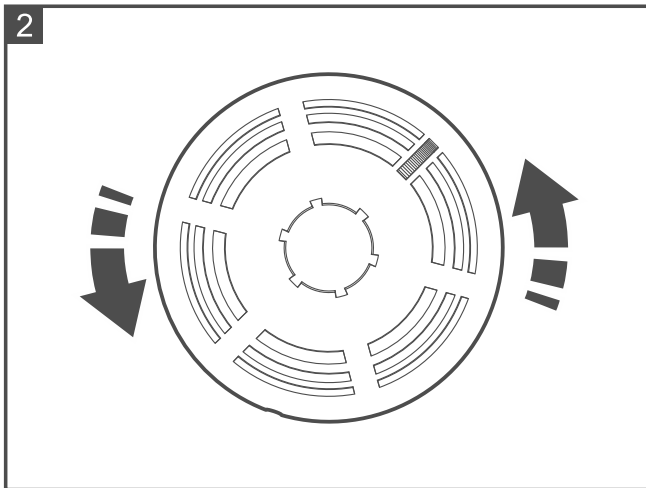

3. Install the battery.
4. Register the detector in the wireless system (see the manual for PERFECTA control panels / VERSA control panels / MTX-300 controller / VERSA-MCU controller / MICRA module).
5. Place the detector where you are planning to install it.
6. Close and open the tamper switch. If the transmission from the detector is received, continue with the installation. If the transmission from the detector is not received, select a different mounting location and repeat the test. It may be sufficient to shift the device ten or twenty centimeters.
7. If the detector is to be mounted on the ceiling using a double-sided mounting tape (Fig. 4):
 - stick the tape to the enclosure base and keep pressing for several seconds.
 - stick the enclosure base to the ceiling and keep pressing for several seconds.



The surfaces to be joined using a double-sided tape must be clean and dry. They must be free from dust and grease.

8. If the detector is to be mounted on the ceiling with screws (Fig. 5):
 - place the enclosure base against the ceiling and mark the location of the mounting holes.
 - drill the holes in the ceiling for wall plugs (anchors). The wall plugs provided with the detector are intended for concrete or brick. For other types of surface (drywall, styrofoam), use other appropriately selected wall plugs.
 - secure the enclosure base to the ceiling with screws.

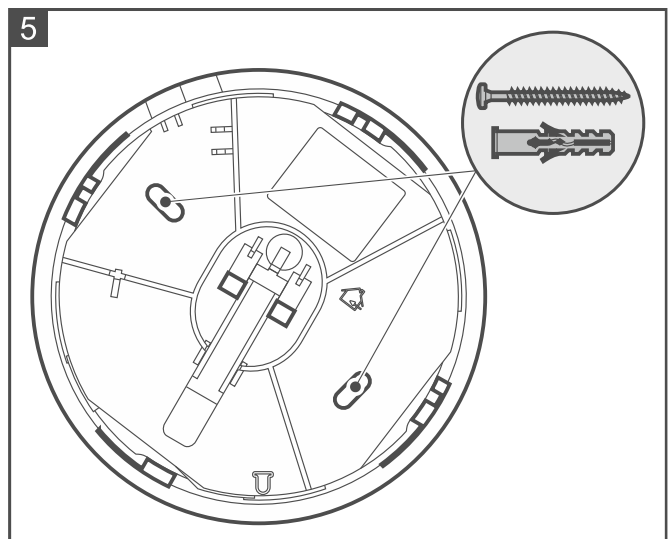
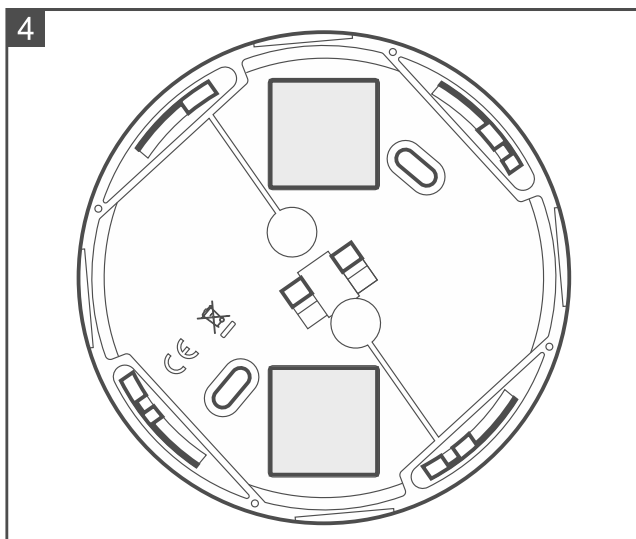

9. Replace the detector cover and lock it with a screw. The screw is provided in the bag together with the wall plugs and screws for mounting.
10. Press the test / reset button (Fig. 1). A fire alarm should be generated soon after.
11. Press again the test / reset button to clear the alarm.



If any work that may cause dirt to build up in the optical chamber is being carried out on the site, put a plastic dust cover on the detector. Remove it after the work is finished.

4. Maintenance

The detector should be subject to regular checks to ensure it is working correctly. The periodic checks should be carried out at least every 6 months. To check whether the detector is working correctly, press the test / reset button (Fig. 1). A fire alarm should be generated.

5. Cleaning the optical chamber

It is recommended to clean the optical chamber at least once a year. Cleaning the chamber is necessary when the LED indicator indicates dirt in the chamber (single flash every 40 seconds).

1. Remove the cover locking screw and open the detector enclosure (Fig. 2 and 3).
2. Remove the battery.
3. Pull the release lever (Fig. 8) to unlock the electronics module and turn it counter-clockwise (Fig. 9).
4. Remove the electronics module with the optical chamber (Fig. 10).
5. Remove the element with the thermistor from the optical chamber cover (Fig. 11).
6. Release the mounting catch (Fig. 12) and remove the optical chamber cover (Fig. 13).
7. Using a soft brush or compressed air, clean the labyrinth in the cover, as well as the base of the optical chamber, paying attention to the recesses where LEDs are installed.
8. Replace the optical chamber cover.
9. Replace the element with the thermistor on the optical chamber.
10. Secure the electronics module with the optical chamber in the cover and turn it clockwise.
11. Install the battery.
12. Replace the detector cover and lock it with a screw.
13. Press the test / reset button (Fig. 1). A fire alarm should be generated soon after.
14. Press again the test / reset button to clear the alarm.

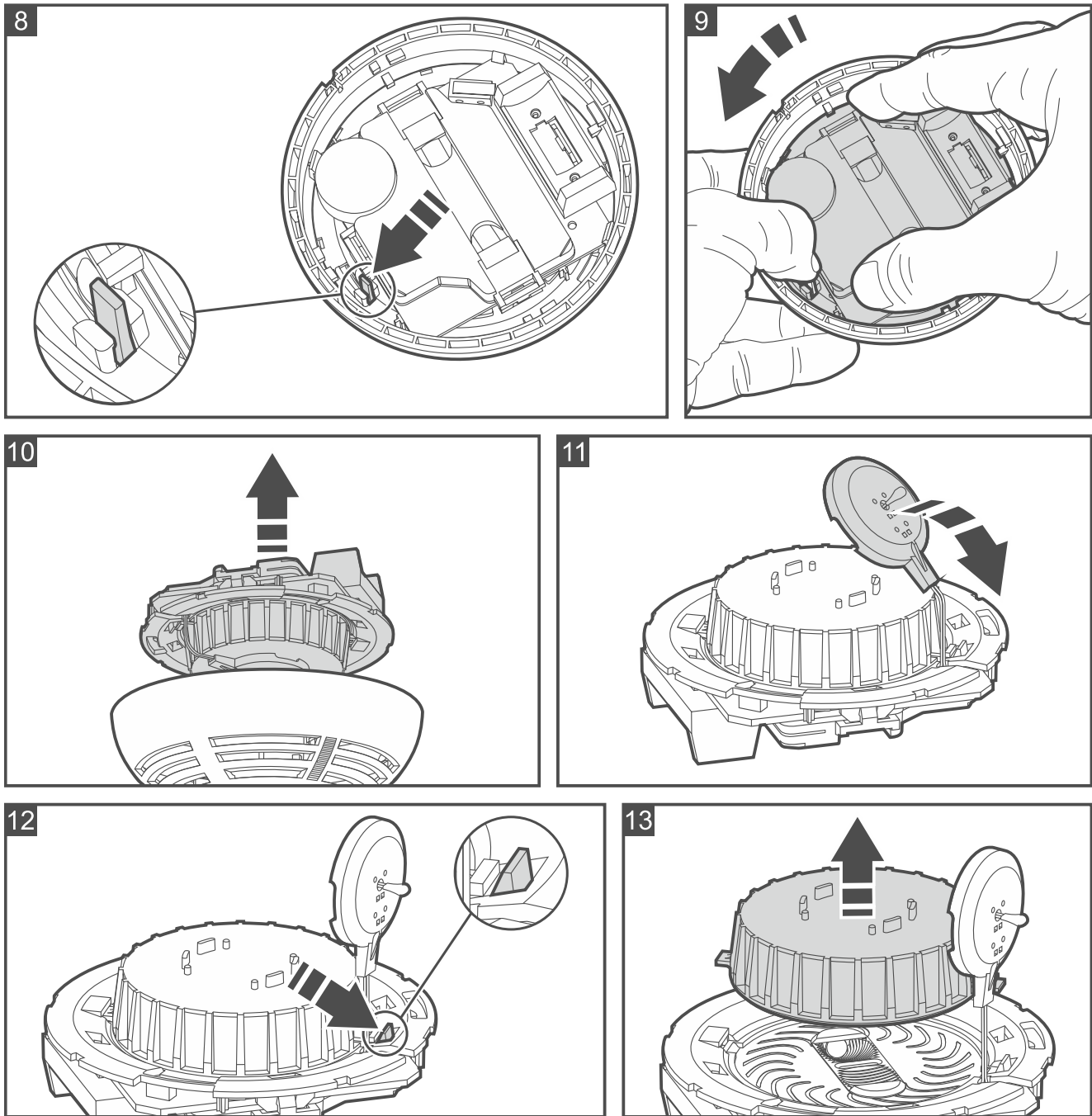

6. Battery replacement



The used batteries must not be discarded, but should be disposed of in accordance with the existing rules for environment protection.

When the detector indicates low battery (single beep every 40 seconds), replace the battery.

1. Remove the cover locking screw and open the detector enclosure (Fig. 2 and 3).
2. Remove the low battery.
3. Install a new CR123A 3 V lithium battery.
4. Replace the detector cover and lock it with a screw.
5. Press the test / reset button (Fig. 1). A fire alarm should be generated soon after.
6. Press again the test / reset button to clear the alarm.

7. Specifications

Operating frequency band	433.05 ÷ 434.79 MHz
Radio communication range (in open area)	up to 200 m
Battery	CR123A 3 V
Battery life expectancy	up to 3 years
Standby current consumption	50 µA
Maximum current consumption	20 mA
Static response temperature	54°C
Operating temperature range.....	0 °C...+55 °C
Maximum humidity	93±3%
Enclosure dimensions.....	ø108 x 61 mm
Weight.....	170 g