

integra

Alarm control panel

INTEGRA 128-WRL

Firmware version 1.21

EN

CE



INSTALLER MANUAL

integra-wrl_i_en 11/22

Satel®

SATEL sp. z o.o. • ul. Budowlanych 66 • 80-298 Gdańsk • POLAND
tel. +48 58 320 94 00
www.satel.pl

IMPORTANT

The security alarm system should be installed by qualified personnel.

Prior to installation, please read carefully this manual in order to avoid mistakes that can lead to malfunction or even damage to the equipment.

Disconnect power before making any electrical connections.

Changes, modifications or repairs not authorized by the manufacturer shall void your rights under the warranty.

SATEL aims to continually improve the quality of its products, which may result in changes in their technical specifications and software. Current information about the changes being introduced is available on our website.

Please visit us:
<https://support.satel.pl>

Hereby, SATEL sp. z o.o. declares that the radio equipment type INTEGRA 128-WRL is in compliance with Directive 2014/53/EU. The full text of the EU declaration of conformity is available at the following internet address: www.satel.pl/ce

The following symbols may be used in this manual:



- note;



- caution.

Changes made to the firmware version 1.21

Keypads	Support for INT-TSG2 and INT-TSH2 keypads with firmware version 2.01.
Expansion modules	Support for ACU-220 and ACU-280 controllers with firmware version 6.05 and 6.06.
Zones	The 82. ARM/DISARM type zone can control a group of partitions.
Outputs	<p>New output type: 120. THERMOSTAT.</p> <p>New parameters and options for the 120. THERMOSTAT type output:</p> <ul style="list-style-type: none">– TEMPERATURE DETECTOR,– TEMPERATURE T1,– TEMPERATURE T2,– HYSTERESIS,– OUTPUT FORCING T1,– TIMERS CONTROLLING T1/T2,– EDITION IN ART-200.
User functions	New function: TEMPERATURES.

CONTENTS

1.	General.....	3
2.	Features.....	3
3.	Keypads.....	5
3.1	Features of keypads with mechanical keys.....	6
4.	Expansion modules.....	6
4.1	Modules to be connected to the keypad bus.....	6
4.2	Modules to be connected to the expander bus.....	7
4.3	Wireless devices supported by the control panel.....	9
4.3.1	ABAX.....	9
4.3.2	ABAX 2.....	9
5.	System installation.....	10
5.1	Installation plan.....	10
5.2	Estimation of the system current consumption.....	11
5.3	Cabling.....	11
5.4	Installation of control panel mainboard.....	11
5.4.1	Description of the mainboard.....	12
5.5	Connecting devices to the keypad bus.....	14
5.5.1	Addressing devices connected to the keypad bus.....	15
5.5.2	Numeration of keypad zones.....	16
5.5.3	Connecting computer to the keypad RS-232 port.....	16
5.6	Connecting devices to the expander bus.....	17
5.6.1	Connecting the INT-VG or INT-AV module or CA-64 SM expander.....	18
5.6.2	Addressing devices connected to the expander bus.....	18
5.7	Connecting the detectors.....	18
5.7.1	End-of-line resistors.....	19
5.8	Connecting the sirens.....	20
5.9	Connecting power supply.....	20
5.9.1	Main power supply.....	20
5.9.2	Backup power supply.....	21
5.9.3	Control panel power-up / start-up procedure.....	21
5.10	First start-up of the control panel.....	21
5.11	Emergency procedure of the control panel start-up.....	22
5.12	GSM communicator start-up.....	23
5.13	Installation of wireless devices.....	24
5.13.1	Adding new wireless devices.....	25
5.13.2	Removing wireless devices.....	27
5.14	Connecting computer to the control panel.....	27
5.15	Connecting the external modem.....	28
5.15.1	Configuring settings of the modem to be connected to control panel.....	29
5.16	Connecting the printer.....	30
6.	Numeration of zones and outputs in the system.....	31
7.	Replacing the battery on control panel mainboard.....	32
8.	Specifications.....	32
8.1	Control panel.....	32
8.2	INT-KLCD keypad.....	33
8.3	INT-KLCDR keypad.....	33
8.4	INT-KLCDL keypad.....	33
8.5	INT-KLCDS keypad.....	34
8.6	INT-KLCDK keypad.....	34
8.7	INT-KLFR keypad.....	34
9.	Manual update history.....	34

1. General

This manual applies to the INTEGRA 128-WRL control panel. The manual also describes keypads compatible with the control panel and other devices that may be included in the security alarm system.

The INTEGRA 128-WRL control panels meet the requirements of the following standards:

- EN 50131-1 Grade 2,
- EN 50131-3 Grade 2,
- EN 50131-6 Grade 2,
- EN 50130-4,
- EN 50130-5 Class II.

2. Features

System structure

- 32 partitions.
- 8 objects (subsystems).

Zones

- 8 programmable hardwired zones on the control panel mainboard:
 - support for NO and NC type detectors, as well as roller shutter and shock detectors,
 - support for Single EOL and Double EOL configuration,
 - programmable value of end-of-line resistors,
 - several dozen zone types.
- Maximum number of programmable zones: 128.

Outputs

- 8 programmable hardwired outputs on the control panel mainboard:
 - 2 high-current outputs,
 - 6 low-current outputs, OC type,
 - over 100 functions,
 - execution of custom control functions due to the possibility of programming complex logic operations on the outputs.
- Maximum number of programmable outputs: 128.
- 3 high-current outputs on the control panel mainboard with power supply output functionality.

Communication buses

- Keypad bus for connecting up to 8 devices.
- Expander bus for connecting up to 32 devices.

Wireless devices

- Integrated wireless interface of the ABAX system to allow operation of:
 - up to 48 ABAX 2 / ABAX wireless devices,
 - up to 248 APT-200 / APT-100 keyfobs.
- Two-way encrypted radio communication in the 868 MHz frequency band

Communication

- GSM/GPRS communicator to allow:
 - events reporting,

- event messaging,
- checking the alarm system status by telephone (DTMF or SMS),
- remote control of the alarm system outputs by telephone (DTMF),
- remote control of the alarm system using SMS messages.
- Built-in GSM modem to allow remote operation and programming of the alarm system (300 bps or CSD transmission).

Reporting

- Reporting events to two monitoring stations:
 - several communication formats (including Contact ID and SIA),
 - 4 telephone numbers (2 main + 2 backup ones),
 - 9 identifiers.
- Several ways to send event codes to the monitoring station:
 - GPRS transmissions (encrypted) – TCP or UDP,
 - SMS messages,
 - GSM voice link.
- Capability of reporting events via the Ethernet (TCP or UDP), when the ETHM-1 / ETHM-1 Plus module is connected.

Messaging

- Event messaging to 16 phone numbers in the form of:
 - 16 voice messages played back by an additional module (INT-VG, CA-64 SM or SM-2),
 - 64 text messages defined by the installer (PAGER or SMS).

Event log

- 21503 events.
- A separate memory space to store events required by the EN 50131 standard for Grade 2.
- Saving the content of received SMS messages to the event log.
- Event log printing capability.

Users

- 8 master users (administrators).
- 240 users.
- Capability to assign to the user:
 - a code,
 - a proximity card (125 kHz passive transponder, which may be in the form of a card, tag, etc.),
 - DALLAS iButton (chip),
 - keyfob.
- Several user types.
- Authority level determining the scope of access to the system.

Additional features

- Access control functions realized by means of additional modules.
- 64 system timers to automatically:
 - arm/disarm the partitions,
 - control the outputs (switching the lights on/off, watering the garden, etc.).
- Partition timers (1 for each partition), to allow automatic arming/disarming.

Programming

- Local programming:
 - keypad,
 - computer with the DLOADX program installed, connected to the control panel RS-232 port.
- Remote programming by using a computer with the DLOADX program installed via:
 - telephone network (modem),
 - Ethernet (optionally, if the ETHM-1 / ETHM-1 Plus module is connected),
 - cellular data network (GPRS transmission).
- Remote programming from a web browser (optionally, after connecting the ETHM-1 / ETHM-1 Plus module).
- Remote programming from a mobile application (optionally, after connecting the ETHM-1 / ETHM-1 Plus module or installing the INT-GSM / INT-GSM LTE module in the system).

Mainboard

- RS-232 port (RJ type socket) to allow:
 - a computer to be connected for programming (DLOADX program), managing the system (GUARDX program) or update of the control panel firmware,
 - connecting to the RS-232 port of the ETHM-1 Plus / ETHM-1 / INT-GSM / INT-GSM LTE module (required for remote programming via these modules),
 - support for external analog, GSM or ISDN modem,
 - serial printer connection (for printing current events).
- Capability of the firmware updating without the need for disassembly of the control panel.
- Socket for connecting the INT-VG voice module, CA-64 SM voice synthesizers expander or SM-2 synthesizer.
- Real time clock with calendar and battery backup.
- LEDs indicating the status of outputs, battery charging system and telephone dialer.
- Electrical protection of all hardwired zones and outputs, and communication buses.
- Switching power supply with short-circuit protection, provided with a battery status supervision and low battery disconnect system.

3. Keypads

The INTEGRA 128-WRL control panel supports the following keypads:

INT-TSG – touchscreen keypad,

INT-TSG2 – touchscreen keypad,

INT-TSH – touchscreen keypad,

INT-TSH2 – touchscreen keypad,

INT-TSI – touchscreen keypad,

INT-KSG – LCD keypad with touch keys,

INT-KLCD – LCD keypad with mechanical keys,

INT-KLCDR – LCD keypad with mechanical keys and built-in proximity card reader,

INT-KLCDK – LCD keypad with mechanical keys,

INT-KLCDL – LCD keypad with mechanical keys,

INT-KLCDS – LCD keypad with mechanical keys,

INT-KLFR – LCD keypad with mechanical keys and built-in proximity card reader.

INT-KWRL – wireless LCD keypad with mechanical keys and built-in proximity card reader (connection of the ACU-120 / ACU-270 controller required).

INT-KWRL2 – wireless LCD keypad with mechanical keys and built-in proximity card reader (connection of the ACU-220 / ACU-280 / ACU-120 / ACU-270 controller required).



The recommended version of the keypad firmware (provides functionality consistent with the requirements of EN 50131 for Grade 2):

- INT-KLCD / INT-KLCDR – 1.08 (or later),
- INT-KLCDK / INT-KLCDL / INT-KLCDS – 6.08 (or later),
- INT-KSG – 1.02 (or later).

The keypads are available in a variety of color options for the enclosure, display and key backlight. The color variant is indicated by the additional designation in the keypad name (e.g. INT-KLCD-GR – green display and key backlight; INT-KLCD-BL – blue display and key backlight).



For information on INT-KSG, INT-KWRL, INT-KWRL2, INT-TSG, INT-TSG2, INT-TSH, INT-TSH2 and INT-TSI keypads, please refer to the manuals delivered with respective keypads.

3.1 Features of keypads with mechanical keys

- Display 2 x 16 characters with backlight.
- LEDs indicating the status of the partitions and the system.
- Backlit keys.
- Built-in sounder.
- 2 programmable hardwired zones:
 - support for NO and NC detectors,
 - support for Single EOL and Double EOL configuration.
- Tamper protection in 2 ways – cover removal and tearing enclosure from the wall.
- RS-232 port (PIN-5 socket) for administration of the security alarm system by means of a computer with the GUARDX program installed.

4. Expansion modules

The expansion modules allow you to not only increase the number of available zones and outputs (wired and wireless), but also enhance the system with additional functionality.



Not all of the following modules meet the requirements of EN 50131 for Grade 2.

4.1 Modules to be connected to the keypad bus

CA-64 PTSA. Mimic board. Enables visualization of the status of the alarm system partitions and zones. The control panels support the mimic boards with electronics version 1.4 (or later) and firmware version 4.0 (or later).

ETHM-1 Plus / ETHM-1. Ethernet communication module. Enables reporting events as well as operating and programming the control panel via the Ethernet network. The recommended module version: 1.06 (or later).

INT-GSM. GPRS communication module. Enables reporting events as well as operating and programming the alarm control panel via the cellular data network (GPRS).

INT-GSM LTE. LTE communication module. Enables reporting events as well as operating and programming the alarm control panel via the cellular data network (LTE/HSPA+/EDGE/GPRS).



The INT-GSM / INT-GSM LTE module can be connected to the keypad bus of the control panel or to the RS-485 bus of the ETHM-1 Plus module. If the ETHM-1 Plus module is connected to the control panel, it is recommended that the INT-GSM / INT-GSM LTE module be connected to the RS-485 bus of the ETHM-1 Plus module.

INT-RS / INT-RS Plus. Interface for systems integration. Makes it possible to connect the computer with the GUARDX program, report events through a special external device, or operate the control panel using software other than that offered by SATEL.

4.2 Modules to be connected to the expander bus

INT-RX / INT-RX-S. 433 MHz keyfobs receiver expansion module. Enables operation of the alarm system using the 433 MHz keyfobs.

INT-CR. Proximity card arm/disarm device. Enables arming / disarming and alarm clearing in many partitions by means of proximity cards, proximity tags and other passive transponders.

INT-S / INT-SF / INT-SK. Partition keypad. Enables arming / disarming and alarm clearing in one partition. Can perform access control functions.

INT-SCR. Multifunctional keypad. It can work as:

INT-S. Partition keypad.

INT-SCR. Partition keypad with reader. Functionality similar to that of the partition keypad.

INT-ENT. Entry keypad. It allows the user to activate delay for the 3. INTERIOR DELAYED type zones. After expiry of the time period preset on the keypad, unless the system is disarmed, the interior delayed zones will again act as instant ones.

INT-SZ / INT-SZK. Code lock. Enables performance of the access control functions.

INT-R. Universal expander for card / chip readers. Supports the proximity card readers manufactured by SATEL, readers with WIEGAND 26 interface or DALLAS chip readers. Enables performance of the access control functions.

INT-E / CA-64 E / CA-64 EPS. Ekspander wejść. Umożliwia rozbudowę systemu o 8 programowalnych wejść przewodowych.

INT-ADR / CA-64 ADR. Addressable zone expander. Adds 48 addressable zones to the security system. Control panels support the addressable zone expanders with firmware version 1.5 (or later).

INT-O / INT-ORS / CA-64 O / CA-64 OPS. Ekspander wyjść. Umożliwia rozbudowę systemu o 8 programowalnych wyjść przewodowych.

INT-PP / INT-IORS / CA-64 PP. Ekspander wejść i wyjść. Umożliwia rozbudowę systemu o 8 programowalnych wejść i wyjść przewodowych.

ACU-220 / ACU-280. ABAX 2 wireless system controller. Enables the alarm system to be operated using the ABAX 2 keyfobs and the ABAX 2 bidirectional wireless devices to be used in the alarm system.

ACU-120 / ACU-270 / ACU-100 / ACU-250. ABAX wireless system controller. Enables the alarm system to be operated using the ABAX 2 / ABAX keyfobs and the ABAX 2 / ABAX bidirectional wireless devices to be used in the alarm system.

INT-VG. Voice module. Allows remote operation of the control panel from the telephone keypad (interactive voice menu). It can store 16 voice messages for telephone messaging.

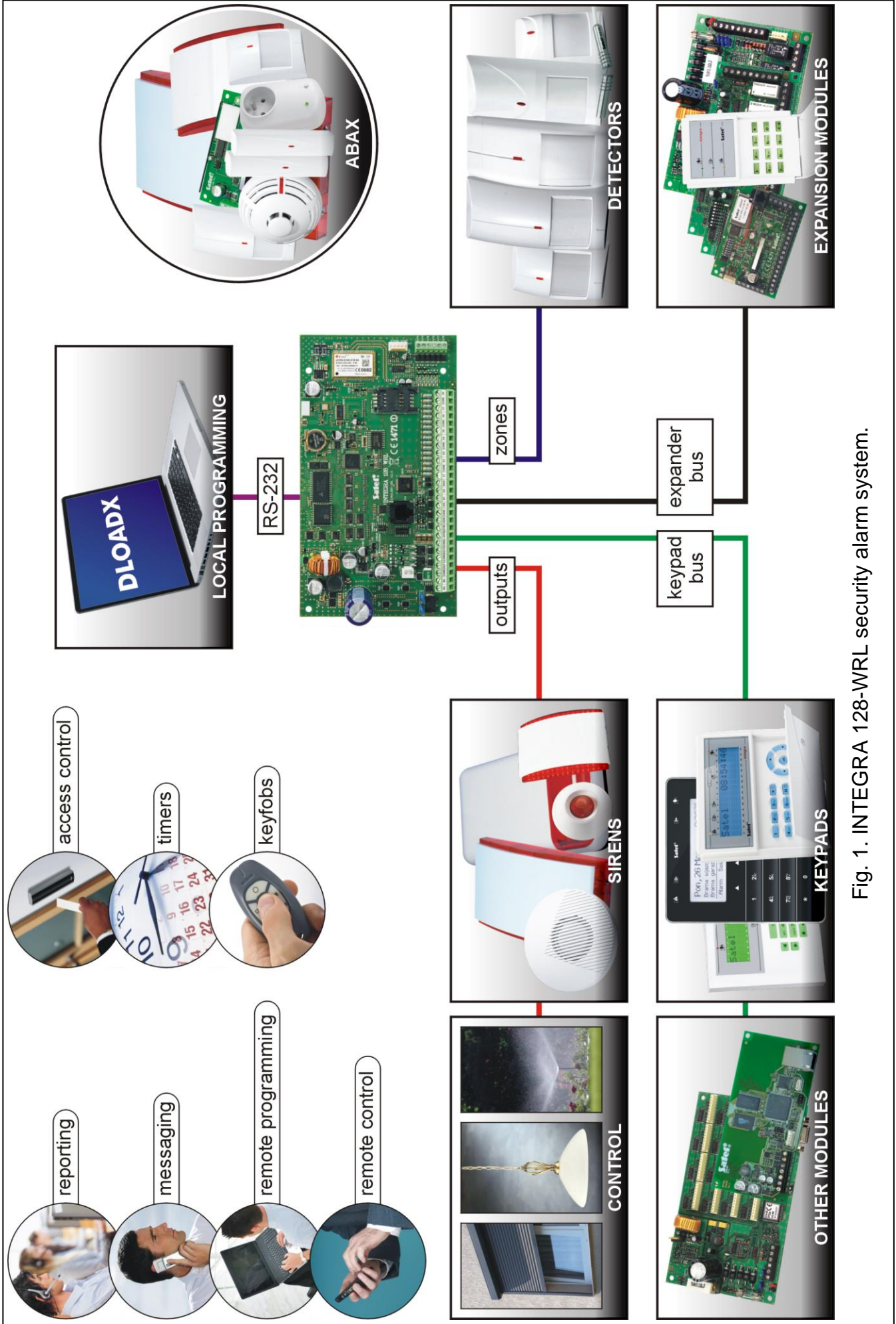

Fig. 1. INTEGRA 128-WRL security alarm system.

INT-VMG. Voice message generator. Plays back prerecorded messages when specified events occur in the system.

INT-AV. Audio alarm verification module. Enables remote audio alarm verification to eliminate false alarms.

INT-KNX / INT-KNX-2. KNX integration module. Enables interfacing of the control panel with the KNX system.

4.3 Wireless devices supported by the control panel

4.3.1 ABAX

Detectors

- AFD-100 – wireless water flood detector.
- AGD-100 – wireless glass-break detector.
- AMD-100 – wireless magnetic contact.
- AMD-101 – dual channel wireless magnetic contact.
- AMD-102 – wireless magnetic contact with input for roller shutter detector.
- AMD-103 – wireless magnetic contact.
- AOCD-250 – wireless outdoor dual technology curtain detector.
- AOD-200 – wireless outdoor dual technology motion detector.
- APD-100 – wireless passive infrared detector.
- APMD-150 – wireless dual motion detector.
- ARD-100 – wireless reorientation detector.
- ASD-110 – wireless smoke and heat detector.
- ASD-150 – wireless smoke detector.
- ATD-100 – wireless temperature detector.
- AVD-100 – wireless vibration detector and magnetic contact.

Sirens

- ASP-105 – wirelessly triggered outdoor siren.
- ASP-205 – wireless indoor siren.

Other

- ACX-200 – hardwired zone / output expander.
- ACX-201 – hardwired zone / output expander with power supply.
- ARF-100 – radio signal level tester.
- ASW-100 E / ASW-100 F – 230 V AC wireless controller.

4.3.2 ABAX 2

Detectors

- | | |
|--------------------|---|
| ADD-200 | - wireless outdoor dusk and temperature detector. |
| AGD-200 | - wireless glass-break detector. |
| AOCD-260 | - wireless outdoor dual technology curtain detector. |
| AOD-210 | - wireless outdoor dual technology motion detector. |
| APD-200 | - wireless passive infrared detector. |
| APD-200 Pet | - wireless passive infrared detector with pet immunity up to 20 kg. |
| APMD-250 | - wireless dual technology motion detector. |

- ASD-200** - wireless smoke and heat detector.
- ASD-250** - wireless smoke detector.
- AXD-200** - wireless multipurpose detector, which can work as:
 - AFD-200** - water flood detector,
 - AMD-200** - magnetic contact,
 - AMD-201** - dual channel magnetic contact,
 - AMD-202** - magnetic contact with input for roller shutter detector,
 - ARD-200** - reorientation detector,
 - ATD-200** - temperature detector,
 - AVD-200** - shock detector and magnetic contact.

Sirens

- ASP-215** - wireless indoor siren.

Hardwired zone / output expanders

- ACX-210** - miniature hardwired zone / output expander.
- ACX-220** - hardwired zone / output expander.

Controllers

- ASW-200** - smart plug.
- ASW-210** - flush-mounted wireless two-channel 230 V AC controller.

Other devices

- APB-200** - wireless panic button.

5. System installation



Disconnect power before making any electrical connections.

The following tools will be useful during installation:

- blade screwdriver 2.5 mm,
- Phillips screwdriver,
- precision pliers,
- flat nose pliers,
- driller c/w a set of drill bits.

5.1 Installation plan

The installation must be preceded by preparation of a plan of the security alarm system. It is advisable to draw up a sketch of the premises and mark on it all the devices that are to be included in the alarm system: control panel, keypads, detectors, sirens, expansion modules etc. When planning the installation location for the control panel and ABAX 2 / ABAX wireless devices, you must take into consideration the range of radio communication. Remember that thick masonry walls, metal partitions, etc. will reduce the range of radio signal. The control panel and other alarm system components should be installed within the protected area.



When writing data to FLASH memory and when the STARTER program is running (control panel firmware is being updated), the expander outputs are deactivated. The status of the control panel mainboard outputs remains unchanged. Keep that in mind when designing the system. It is recommended that devices whose operation must not

be disturbed as a result of writing data to FLASH memory or after launching the STARTER program be connected to the mainboard outputs.

5.2 Estimation of the system current consumption

At the security system planning stage you should sum up the currents consumed by all devices included in the system (control panel mainboard, keypads, additional modules, detectors, sirens, etc.). The calculation should take into account the battery charging current. If the sum of currents exceeds the maximum output current of the control panel power supply, expander with power supply or an additional power supply unit should be used.

The sum of currents consumed by the devices connected to the power supply unit (expander with power supply) must not exceed the power supply output current.

If you plan to connect devices to particular power outputs (of the control panel, expander with power supply, etc.), remember that the sum of currents consumed by these devices must not exceed the maximum current carrying capacity of those outputs.

5.3 Cabling

It is recommended that unscreened straight-through cable be used for making electric connections between devices included in the system.



If you use the twisted-pair type of cable, remember that the DTM and CKM / DT and CK (data and clock) signals must not be sent through one twisted-pair cable.

It is recommended that separate cables be used for keypad bus and expander bus.

Select cross-section of the power supply wires so that the supply voltage drop between the power supply and the supplied device should not exceed 1 V as against the output voltage.

In order to guarantee correct functioning of the system components it is important that resistance and capacitance of the signal wires be as low as possible. When the distances between the devices are greater, several wires connected in parallel may have to be used for each signal, in order to reduce conductor resistance. This, however, may lead in consequence to an increase in conductor capacitance. Too high resistance or capacitance of the cables connecting the control panel to keypads or expansion modules can prevent the devices from working correctly (e.g. the control panel will be unable to identify devices, absence of devices will be reported, etc.). When selecting the length of cables, follow recommendations set out in sections on connection of particular types of devices.

When making the cabling, remember that there must be sufficient distance between the low-voltage wires and the 230 V AC power supply wires. Avoid running the signal cables in parallel to and in close proximity of the 230 V AC supply cables.

5.4 Installation of control panel mainboard



The control panel mainboard contains electronic components sensitive to electric charges.

You must complete all wiring, connections and device installations before connecting the battery or applying AC mains to the control panel.

The control panel should be installed indoors, in spaces with normal humidity of air. The control panel must be protected against unauthorized access.

It is recommended that the control panel be mounted high above the floor. This will allow you to get a better range of radio communication and avoid the risk of the control panel being accidentally covered by people moving around the premises.

A 230 V AC power supply circuit with protective grounding must be available at the control panel installation place.

5.4.1 Description of the mainboard

Description of terminals:

AC	- power supply inputs (18 V AC)
COM	- common ground
OUT1...OUT2	- programmable high-current outputs (if output is not used, the 2.2 k Ω resistor should be connected between the output and common terminals)
+KPD	- power supply output for powering the devices connected to keypad bus (13.6...13.8 V DC)
DTM	- keypad bus data
CKM	- keypad bus clock
+EX	- power supply output for powering the devices connected to expander bus (13.6...13.8 V DC)
DT	- expander bus data
CK	- expander bus clock
AUX	- power supply output (13.6...13.8 V DC)
Z1...Z8	- zones
OUT3...OUT8	- programmable low-current outputs, OC type

Explanations for Fig. 2:

- ① battery connection cables (red +, black -).
- ② LEDs indicating the status of high-current outputs.
- ③ pins for setting battery charging current:
 - pins shorted (jumper on) – 400 mA
 - pins open (no jumper) – 800 mA
- ④ CHARGE LED indicating the battery charging.
- ⑤ RS-232 port (RJ type socket).
- ⑥ STTS LED indicating the operation status of the supervision circuit of ABAX wireless system.
- ⑦ RESET pins for emergency starting the control panel (see: EMERGENCY PROCEDURE OF THE CONTROL PANEL START-UP p. 22).
- ⑧ lithium battery for clock and RAM backup. Its removal will result in loss of the clock settings and all data stored in RAM.



Insert the battery in its socket just before starting the control panel (but not earlier).

After 5 years of operation, check the control panel battery status.

- ⑨ socket to connect antenna for communication with ABAX 2 / ABAX wireless devices.
- ⑩ SIM card socket. It is not recommended to insert the SIM card into its socket before the card PIN code has been programmed in the control panel.

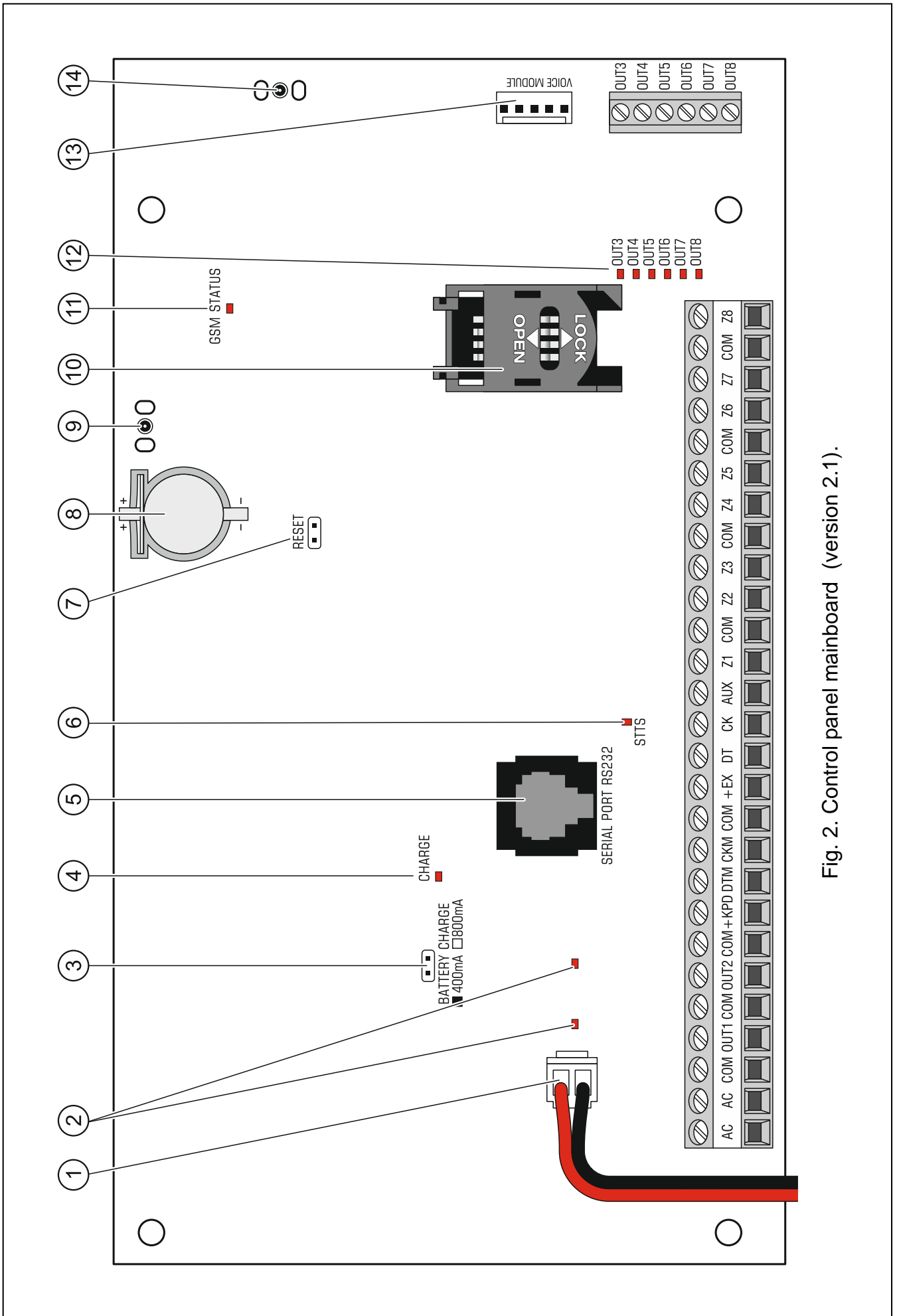

Fig. 2. Control panel mainboard (version 2.1).

- ⑪ GSM STATUS LED indicating the communicator and cellular network status:
- OFF – the communicator disabled,
 - ON – outgoing voice call,
 - lit, getting dimmed every 0.5 second – incoming voice call,
 - flashing slowly – CSD communication,
 - flashing rapidly – GPRS communication
 - 1, 2, 3 or 4 flashes every 2 seconds – communicator standby mode (the number of flashes indicates the cellular signal level).
- ⑫ LEDs indicating the status of low-current outputs.
- ⑬ socket for connecting the INT-VG voice module, INT-AV audio alarm verification module, CA-64 SM voice synthesizer expander or SM-2 synthesizer.
- ⑭ socket for GSM/GPRS communication antenna.

5.5 Connecting devices to the keypad bus

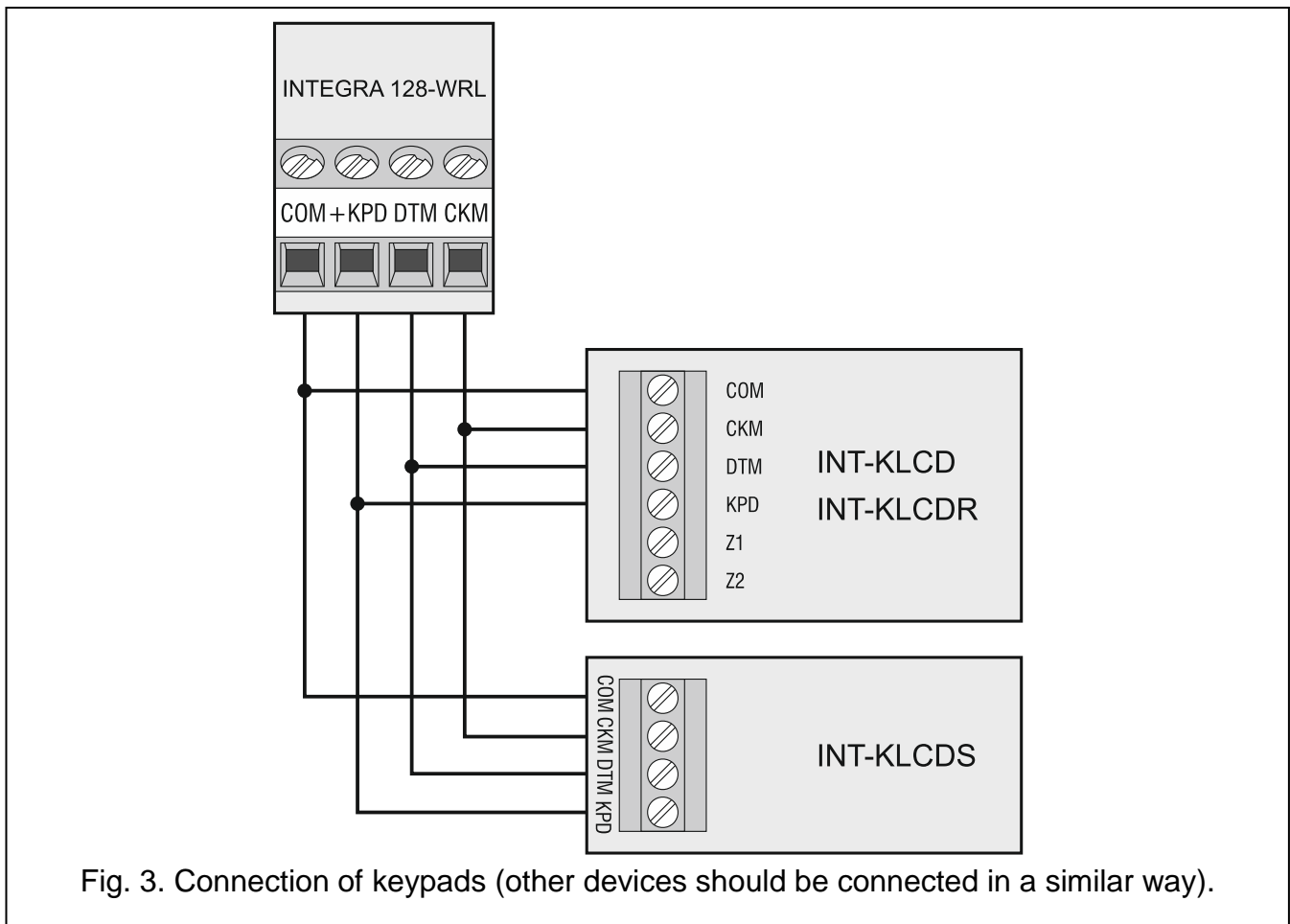

Fig. 3. Connection of keypads (other devices should be connected in a similar way).



The bus wires must be run in one cable.

*The distance between the keypad (or other device to be connected to keypad bus) and the control panel may be up to **300 m**.*

Devices installed far from the control panel may be supplied locally from a separate power source.

Supply voltage measured at the LCD keypad terminals, with the display and key backlight on, must not be lower than 11 V.

The Table 1 shows the number of wires required for correct connection of the device to the keypad bus if conductors with 0.5 mm diameter are used.

Distance	+KPD	COM	CKM	DTM
	Number of wires			
up to 100 m	1	1	1	1
100-200 m	2	2	1	1
200-300 m	4	4	2	2

Table 1.

5.5.1 Addressing devices connected to the keypad bus

Each device to be connected to the keypad bus must have its own individual address from the 0 to 7 range. Addresses must not repeat (the control panel does not support devices having identical addresses). It is recommended that consecutive addresses be assigned starting from 0.

In keypads, the address is set by software means. By default, address 0 is set. When started with factory default settings, the control panel will support all keypads connected to the bus, irrespective of what addresses are set in them. Thus it is possible to set correct individual addresses in the keypads and perform identification of all devices connected to the bus.

In other devices to be connected to the keypad bus, the address is to be set using the DIP-switches or the pins.

Programming keypad address by means of the service function

1. Enter the **service code** (by default 12345) and press the ***** key.
2. Using the **▲** or **▼** keys, find the SERVICE MODE item in the function list and press the **#** or **▶** key.
3. Start the KEYPADS ADDR. function (**▶**STRUCTURE **▶**HARDWARE **▶**IDENTIFICATION **▶**KEYPADS ADDR.).
4. The message shown in Fig. 4 will appear on display of all keypads connected to the control panel.

The image shows a rectangular LCD display with a black background and white pixelated text. The text reads: "This LCD address" on the first line, "(n, 0-7):" on the second line, and a single underscore "_" on the third line.

n=0...7, currently set keypad address

Fig. 4. Programming the keypad address with the service function.

5. Enter a proper address from the 0-7 range in the selected keypad(s). The address change will be confirmed by four short beeps followed by one long beep.
6. To terminate the address change function, press the ***** key. The function will be terminated automatically after 2 minutes from being started. Termination of the function is equivalent to restarting the keypad (return to the main service mode menu will follow in the keypad from which the function has been started).

Programming keypad address without entering the service mode

This method of address programming is particularly useful when – due to repeating addresses – the keypad support has been disabled and entering the service mode is impossible.

1. Disconnect the keypad power supply (KPD) and the CKM and DTM signal wires.
2. Short-circuit the keypad CKM and DTM terminals.
3. Switch on keypad power supply.
4. A message indicating the current address will appear on the display.
5. Enter a new address. The keypad will confirm execution of the function by four short beeps followed by one long beep. If it is necessary to change the entered address, press the * key (keypad restart will follow and a corresponding message will appear on the display).
6. Disconnect the keypad power supply.
7. Open the keypad CKM and DTM terminals.
8. Connect the keypad correctly to the control panel.

5.5.2 Numeration of keypad zones

The address set in the keypad defines which numbers in the system will be assigned to the keypad zones (see Table 2). You can define for each keypad whether or not its zones will be used in the system. If the zone numbers of keypad and expander coincide, the keypad zones have priority (in such a case, the corresponding expander zones will not be supported).

Keypad address	Zone number in the system	
	Z1	Z2
0	113	114
1	115	116
2	117	118
3	119	120
4	121	122
5	123	124
6	125	126
7	127	128

Table 2.

5.5.3 Connecting computer to the keypad RS-232 port

In some keypads, the RS-232 port makes it possible to connect a computer with the GUARDX program installed (see Fig. 5). It is recommended that the straight-through unshielded cable be used for making the connection (using the twisted-pair type of cable, e.g. UTP, STP, FTP, is not advisable). The distance between computer and keypad can be up to **10 m**.

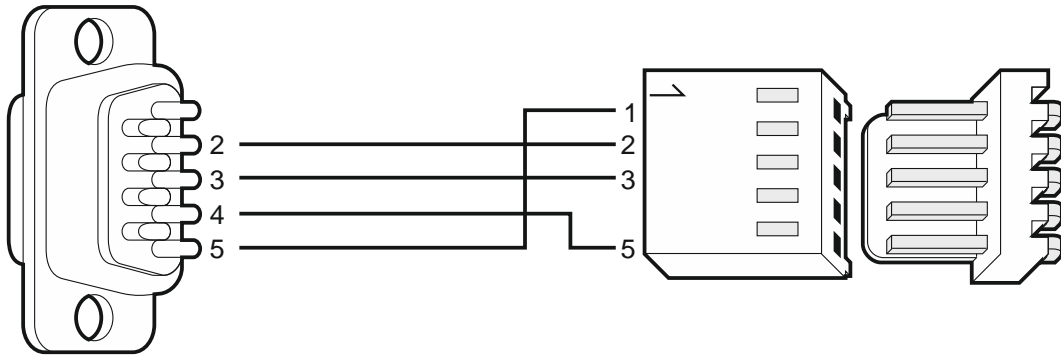

Fig. 5. Computer connection to the keypad RS-232 port. Shown on the right is the keypad interface. Shown on the left is the DB-9 female connector from soldering points side.



Activate the Communication RS option in keypads to which the computer with GUARDX program is connected. Data exchange with the computer will begin automatically as soon as the GUARDX program is started.

5.6 Connecting devices to the expander bus

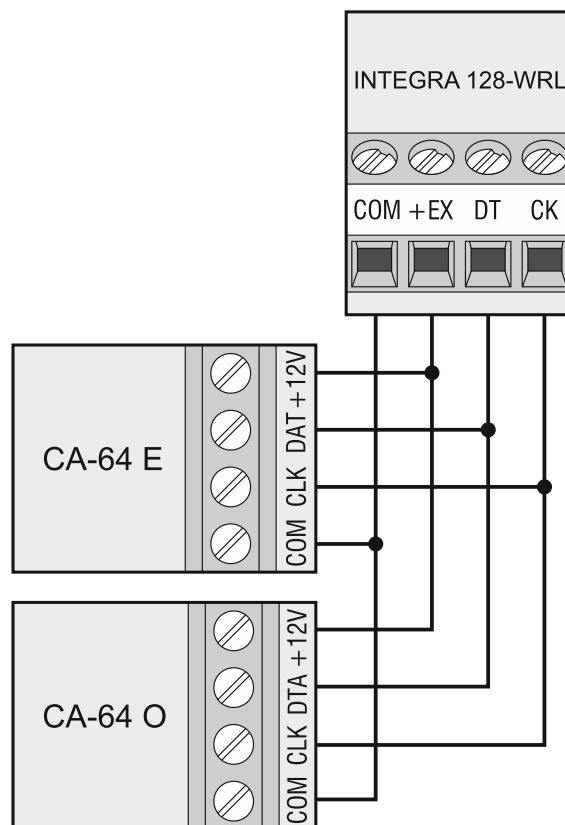

Fig. 6. Connection of modules without power supply.



The bus wires must be run in one cable.

The total length of the expander bus may not exceed **1000 m**.

The module may be powered directly from the control panel if the distance between control panel and module does not exceed 300 m. Where the distance is greater,

another source of power must be provided for the module (a power supply unit or an expander with power supply).

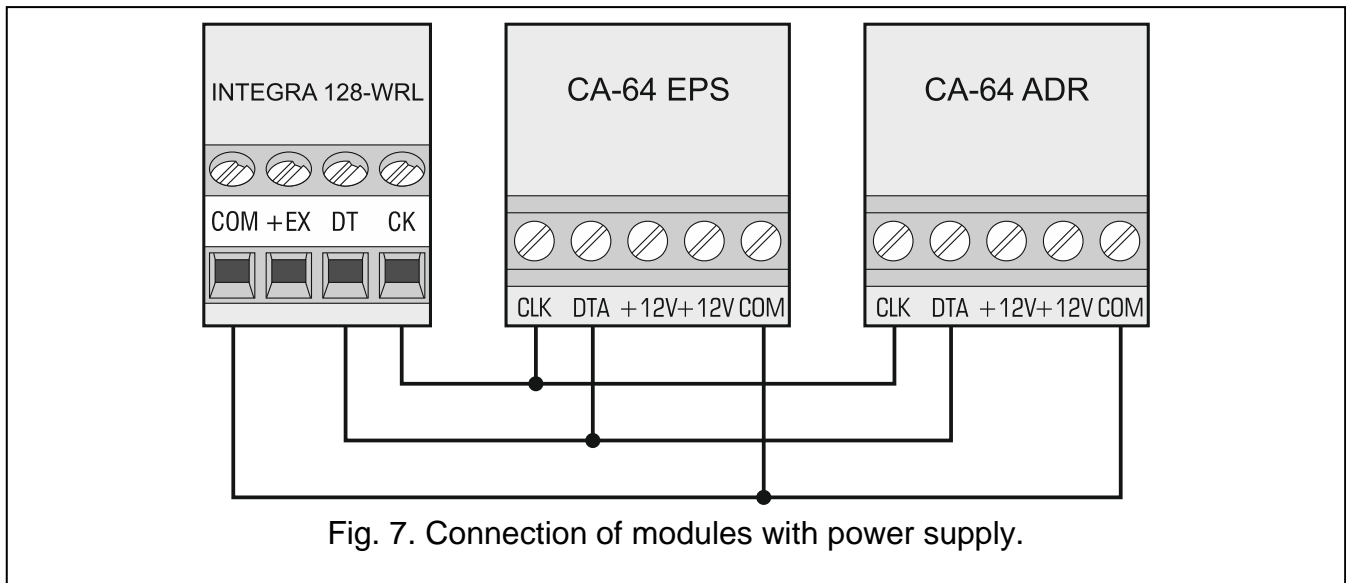

Fig. 7. Connection of modules with power supply.

The Table 3 shows the number of wires required for correct connection of the device to the expander bus if conductors with 0.5 mm diameter are used.

Distance	CK	DT	COM
	Number of wires		
up to 300 m	1	1	1
300 – 600 m	2	2	2
600 – 1000 m	2	2	4

Table 3.

5.6.1 Connecting the INT-VG or INT-AV module or CA-64 SM expander

When connecting the INT-VG voice module, INT-AV audio alarm verification module or the CA-64 SM voice synthesizer expander, the CLK and DTA wires only are to be connected to the bus. Each of these devices is additionally provided with the PIN5 connector, which is to be connected to the dedicated socket on the control panel electronics board.

5.6.2 Addressing devices connected to the expander bus

Each device to be connected to the expander bus must have its own individual address from the 0 to 31 range. The addresses of devices must not repeat (the control panel does not support devices having identical addresses). It is recommended that consecutive addresses be assigned starting from 0. In most devices, the address is set by means of DIP-switches.

i The address affects numeration of zones and outputs in the system (see section NUMERATION OF ZONES AND OUTPUTS IN THE SYSTEM p. 31).

5.7 Connecting the detectors

How the detector is connected to the zone must be suitable for the configuration chosen for that zone. The zones on the control panel mainboard support the following configurations:

NC – the wiring type dedicated to connecting devices with the NC (normally closed) alarm output. Opening the circuit will trigger an alarm.

NO – the wiring type dedicated to connecting devices with the NO (normally open) alarm output. Closing the circuit will trigger an alarm.

EOL – this wiring type may be used to connect devices having the NC or NO alarm output. Closing or opening the circuit will trigger an alarm.

2EOL/NC – the wiring type recommended to connect detectors having the NC alarm output and a tamper output. The zone can recognize 3 states: normal, alarm and tamper.

2EOL/NO – the wiring type similar as 2EOL/NC, but for detectors with the NO alarm output.

Roller – the wiring type dedicated to connecting roller shutter detectors.

Vibration – the wiring type dedicated to connecting shock detectors. The zone will also accept connection of a detector with the NC alarm output (e.g. a shock detector and a magnetic contact can be connected in series).

Follow output – in case of this configuration the detector should not be connected. The zone status depends only on that of the selected output (the output is not to be physically connected to the zone).

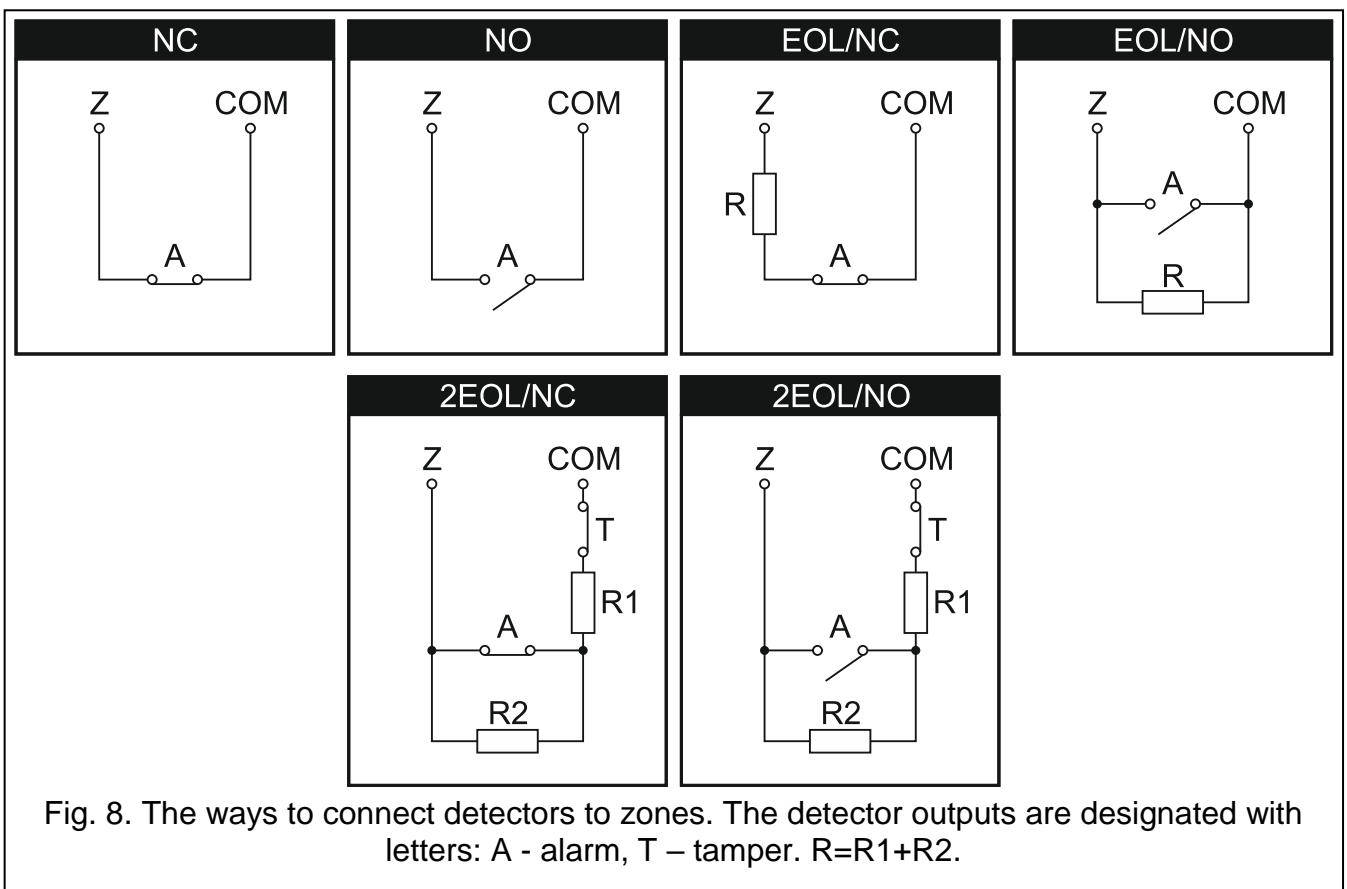

5.7.1 End-of-line resistors

The value of R1 and R2 resistors is programmable within the range from 500 Ω to 15 k Ω (the sum of preset values may not exceed 15 k Ω – see PROGRAMMING manual). The factory preset values are as follows:

R1 = 1.1 k Ω ,

R2 = 1.1 k Ω .



If the resistor value in the keypad or expander is not programmable, in Single EOL configuration, the 2.2 k Ω resistor is required, and in Double EOL (2EOL) configuration – two 1.1 k Ω resistors.

5.8 Connecting the sirens



If high-current output is not used, the 2.2 kΩ resistor should be connected between the output and common terminals.

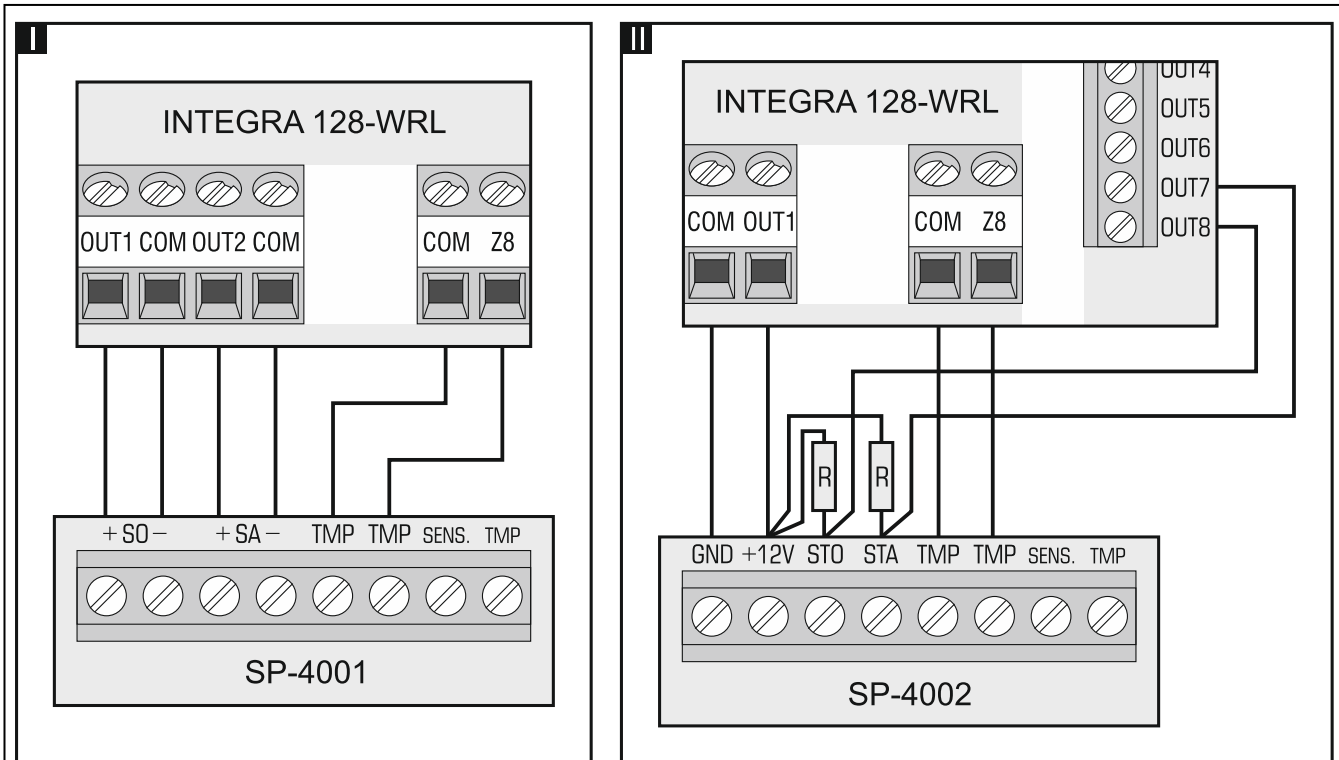

Fig. 9. The way of connecting sirens. I – siren without own power supply – alarm signaling triggered by high-current outputs. II - siren with own power supply – alarm signaling triggered by low-current outputs, the high-current serving as power supply output. The value of resistors R is 2.2 kΩ. In both cases, tamper circuit is connected to zone Z8.

5.9 Connecting power supply



Complete all wiring to the control panel before connecting AC power or the battery.

Before connecting power supply, insert the clock and RAM backup battery into its socket on the mainboard.

5.9.1 Main power supply

The control panel requires 18 V AC (±10%) power supply. Using a transformer of at least 40 VA power is recommended.



Do not connect two devices with power supply to one-section transformer.

Before connecting transformer to a circuit from which it will be powered, make sure the circuit is de-energized.

The transformer should be permanently connected to the 230 V AC mains supply. Before you make the cabling, familiarize yourself with the electrical installation of the facility. Make sure that the circuit you choose for powering the control panel will be always alive. The power supply circuit should be protected with a proper safety device. The owner or user of the alarm

system should be instructed on how to disconnect the transformer from the mains (e.g. by indicating the fuse which protects the control panel supply circuit).

5.9.2 Backup power supply

A 12 V lead-acid sealed battery should be connected to the control panel as a backup power source. The battery capacity must be adequately selected to match current consumption in the system. According to EN 50131 Grade 2, the battery must ensure operation of the system without mains supply for 12 hours.



Do not connect deeply discharged battery to the control panel (with voltage across unloaded terminals below 11 V). The battery should be precharged with a proper charger.

The used batteries must not be discarded, but should be disposed of in accordance with the existing rules for environment protection.

If the battery voltage drops below 11 V for longer than 12 minutes (3 battery tests), the control panel will indicate battery failure. When the voltage goes down to approx. 10.5 V, the battery will be disconnected.

5.9.3 Control panel power-up / start-up procedure

1. Deenergize the 230 V AC circuit to which the transformer is to be connected.
2. Connect the 230 V AC wires to the terminals of transformer primary winding.
3. Connect the terminals of transformer secondary winding to the AC terminals on control panel electronics board.
4. Connect the battery to the dedicated leads (positive terminal to RED lead, negative terminal to BLACK lead). **The control panel will not start after connecting the battery alone.** Included in the control panel set are adapters (matching connectors) for connection of battery with twisted cable ends, therefore the battery cable ends should not be cut off.
5. Turn on 230 V AC power supply in the circuit to which the transformer is connected. The control panel will start operating.



If you have any problems with starting the control panel, enter the service mode “from the pins” and restore the factory default settings (see EMERGENCY PROCEDURE OF THE CONTROL PANEL START-UP p. 22).

The above mentioned power-up sequence (first the battery, then the 230 V AC mains) will ensure proper operation of the power supply unit and the electronic protection circuits, thus preventing damage to the alarm system components caused by installation mistakes, if any.



If the control panel power supply has to be disconnected, disconnect the mains first and then the battery. When reconnecting the power supply, observe the above mentioned sequence.

5.10 First start-up of the control panel



After the first start-up of the control panel, it is advisable to restore the factory default settings using the CLEAR ALL function ([SERVICE CODE]* ►SERVICE MODE ►RESTARTS ►CLEAR ALL), and then quit the service mode. When a prompt appears on the keypad display, whether the data should be saved to the FLASH memory, press the “1” key on the keypad.

The control panel with factory settings supports all keypads connected to the bus, irrespective of the addresses set in them. However, it does not allow you to program the system. You will be able to start programming after carrying out the following operations:

1. Setting individual, correct addresses in keypads (see p. 15).
2. Identification by the control panel of devices connected to the keypad bus. The identification can be performed by means of:
 - the keypad ([SERVICE CODE]* ►SERVICE MODE ►STRUCTURE ►HARDWARE ►IDENTIFICATION ►LCD KEYPADS ID.),
 - DLOADX program (“Structure” window →“Hardware” tab →“Keypads” branch →“Keypads identification” button).
3. Identification by the control panel of devices connected to the expander bus. The identification can be performed by means of:
 - the keypad ([SERVICE CODE]* ►SERVICE MODE ►STRUCTURE ►HARDWARE ►IDENTIFICATION ►EXPANDERS ID.),
 - DLOADX program (“Structure” window →“Hardware” tab →“Expansion modules” branch →“Exp. modules identification” button).



The identification function must be run every time when a new device is connected to the bus or the address of a device connected to the bus is changed.

Disconnecting the identified device from the communication bus will trigger a tamper alarm.

Any attempt to replace the identified device with another one having the same address will trigger a tamper alarm.

5.11 Emergency procedure of the control panel start-up

If the control panel fails to start properly, keypads are not supported, codes are not accepted by the control panel etc., despite all connections having been made correctly, follow the steps below:

1. Turn off the control panel power supply (first disconnect the AC power, and then the battery).
2. Put a jumper on the RESET pins located on the control panel mainboard.
3. Turn on the control panel power supply (first connect the battery and then the AC power).
4. Wait about 10 seconds and remove the jumper from the pins. The control panel will enter the service mode. The service mode menu will be displayed on the keypad with the lowest address.



If a computer with the DLOADX program running is connected to the RS-232 port, the service mode will not start (it will be possible to program the control panel locally from the computer).

5. Restore the factory default settings using the CLEAR ALL function (►RESTARTS ►CLEAR ALL).
6. Start the KEYPADS ADDR. function (►STRUCTURE ►HARDWARE ►IDENTIFICATION ►KEYPADS ADDR.) and set individual addresses in the keypads (see p. 15).
7. Identify devices connected to the keypad bus (►STRUCTURE ►HARDWARE ►IDENTIFICATION ►LCD KEYPADS ID.).
8. Identify devices connected to the expander bus (►STRUCTURE ►HARDWARE ►IDENTIFICATION ►EXPANDERS ID.).
9. Exit the service mode using the END SERVICE function.

10. After a prompt appears on the keypad display whether to save the data to the FLASH memory, press the key with the number 1. By saving a copy of the settings to the FLASH memory, the control panel will be able to restore them from a backup copy if an error is detected in the data stored in the RAM memory.
11. After the data are saved to the FLASH memory, the control panel will restart (the keypad display will be blank for a moment). After the restart, the control panel should work properly and you can proceed to programming the system.

5.12 GSM communicator start-up



If the control panel is to transmit data over the cellular network, it is recommended that you use SIM cards with a dedicated tariff plan for M2M (machine-to-machine) communication.

Having started the control panel, you can start up the GSM communicator. A GSM antenna must be connected to the control panel. Support for the GSM communicator must be enabled in the control panel (SERVICE MODE ► STRUCTURE ► HARDWARE ► GSM ► USE GSM PHONE). In order to start up the GSM communicator, do the following:

1. Program the SIM card PIN code. You can do so using:
 - the keypad ([SERVICE CODE]* ► SERVICE MODE ► STRUCTURE ► HARDWARE ► GSM ► PIN CODE),
 - the DLOADX program (“Structure” window → “Hardware” tab → “GSM phone” branch → “PIN” field).
2. Insert the SIM card into the onboard socket (see: Fig. 10). Communicator logging into the cellular network may take a few minutes.

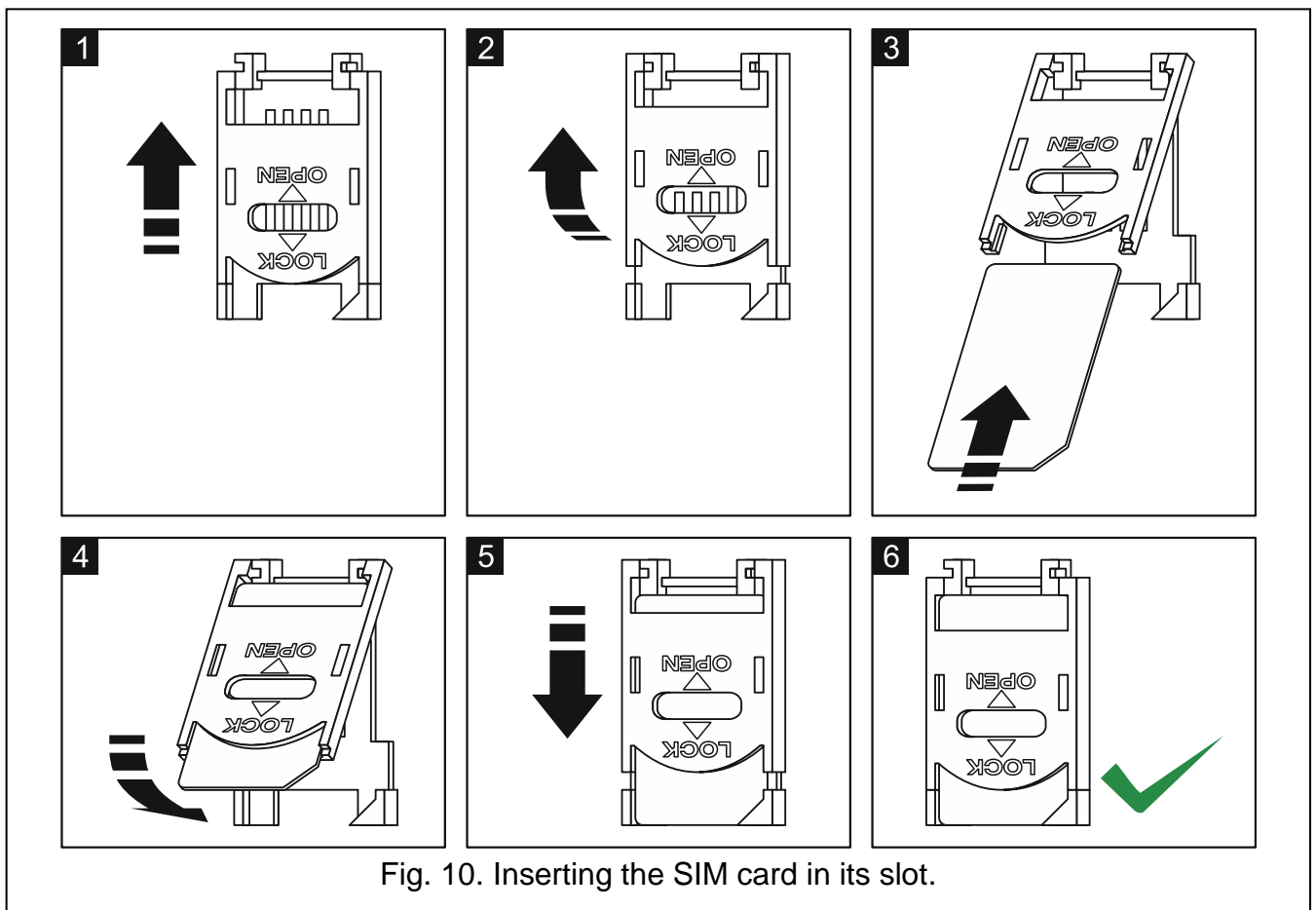

Fig. 10. Inserting the SIM card in its slot.

The user function GSM IMEI/V/SIG. ([CODE]* ► TESTS ► GSM IMEI/V/SIG.) makes it possible to check the level of signal received by the antenna, individual telephone identification number and telephone version. If the signal level is equal to 0, GSM/GPRS communication is impossible. The signal level may be equal to 0 in the following cases:

- antenna not connected or incorrectly connected,
- communicator does not start up properly (e.g. no SIM card, invalid PIN code, blocked SIM card) – in such a case, the control panel should report trouble,
- cellular network out of range.

5.13 Installation of wireless devices

Having started the control panel, you can proceed to installation of the ABAX 2 / ABAX wireless devices. Antenna for communication with the wireless devices must be connected to the control panel.

Before installing a wireless device, check the level of radio signal received by the device from control panel and by the control panel from device at the planned installation place. The ARF-100 tester is a useful tool to check the signal level. The level of signal received by device/control panel may not be lower than 40%. If the radio signal level at the planned installation place is too low, select another installation location. Sometimes it is sufficient to move the device ten or twenty centimeters to obtain a significant improvement of signal quality. You can install the device permanently only after reaching the optimum level of radio signal.

The wireless devices must be registered to the alarm system. This can be done using the LCD keypad or DLOADX program. The control panel can support up to 48 wireless devices, but some devices take up more than one position on the list. For example, after adding to the system the ACX-200 expander, which takes up 4 positions on the list of devices, the control panel will still be able to handle 44 more wireless devices. The number of positions on the list is at the same time the number of zones and, in case of some devices, also outputs which will be taken by the device in the system.

When adding and removing the wireless devices, remember that the identification function registers zones and outputs by groups of 8. Already after adding one wireless device which takes up 1 zone, the control panel will reserve 8 zones in the system for wireless devices. The LCD keypad makes it possible to select the zone to which that device will be assigned. Observe continuity, i.e. avoid leaving any gaps in the list, which will later reduce the number of available zones in the system. Remember to preserve continuity also when removing wireless devices. For example, if the devices registered in the control panel occupy 9 positions on the list, then 16 zones (2x8) are reserved in the system. After removal of the device which occupied position 7 on the list, there will still be 16 zones (2x8) reserved in the system for wireless devices, although 8 positions are actually taken up on the list of wireless devices (see: Table 4). In such a case, it is recommended that the last devices be removed from the list and then added to the system again, so as to fill up the gap in the list and reduce the number of zones reserved for wireless devices.

In case of devices which, in addition to zones, also take up outputs, it is recommended that you add them to the system first. This will allow you to maintain the continuity of use of not the zones alone, but the outputs as well. Table 4 shows a situation in which the siren first output occupies position 8, and the second output – position 9. As a result, 16 outputs have been reserved for wireless devices in the system, though actually 2 outputs are used (the eighth output in the first group of 8 outputs and the first output in the second group of 8 outputs).

In some cases, the gaps in the list of zones/outputs cannot be avoided. It applies to situation when the number of zones/outputs, which is used by the devices, is not a multiple of 8.

It.	list of devices	zones		outputs		
		No	device	No	device	
1	APD-100 detector	8	17	APD-100 detector	17	unused/unavailable
2	APD-100 detector		18	APD-100 detector	18	unused/unavailable
3	AMD-100 detector		19	AMD-100 detector	19	unused/unavailable
4	AMD-100 detector		20	AMD-100 detector	20	unused/unavailable
5	AMD-101 detector		21	AMD-101 detector	21	unused/unavailable
6	^		22	AMD-101 detector	22	unused/unavailable
7			23	unused/unavailable	23	unused/unavailable
8	ASP-105 siren		24	ASP-105 siren	24	ASP-105 siren
9	^	8	25	ASP-105 siren	25	ASP-105 siren
10			26	unused/unavailable	26	unused/unavailable
11			27	unused/unavailable	27	unused/unavailable
12			28	unused/unavailable	28	unused/unavailable
13			29	unused/unavailable	29	unused/unavailable
14			30	unused/unavailable	30	unused/unavailable
15			31	unused/unavailable	31	unused/unavailable
16			32	unused/unavailable	32	unused/unavailable

Table 4. An example of how the wireless devices should not be registered. For devices taking up 8 positions, the system must reserve 16 zones and 16 outputs.

It.	list of devices	zones		outputs		
		No	device	No	device	
1	ASP-105 siren	8	17	ASP-105 siren	17	ASP-105 siren
2	^		18	ASP-105 siren	18	ASP-105 siren
3	APD-100 detector		19	APD-100 detector	19	unused/unavailable
4	APD-100 detector		20	APD-100 detector	20	unused/unavailable
5	AMD-100 detector		21	AMD-100 detector	21	unused/unavailable
6	AMD-100 detector		22	AMD-100 detector	22	unused/unavailable
7	AMD-101 detector		23	AMD-101 detector	23	unused/unavailable
8	^		24	AMD-101 detector	24	unused/unavailable

Table 5. An example of how to correctly register the wireless devices. For 8 devices, the system has reserved 8 zones and 8 outputs.

Several ABAX 2 / ABAX systems can work within each other's range. Automatic synchronization with the wireless systems already in use is always performed at the control panel start-up, and after each operation of addition/removal of supported devices. The number of wireless devices working within each other's range depends on the RESPONSE PERIOD (see: PROGRAMMING manual) and can vary from 150 to 450. The higher the response frequency, the lower the number of devices that can work within each other's range.

5.13.1 Adding new wireless devices

Each wireless device, including the ARF-100 tester, must be registered to the control panel.



Before adding an ABAX 2 device that was previously registered to the ABAX / ABAX 2 system, you must restart it (remove the battery / power the device off for 30 seconds).

When registering a device, you must enter its serial number. The serial number sticker is affixed to the device (location of the sticker is indicated in the manual of the device). The serial number of each ARF-100 tester is 0000500.



Most of the ABAX 2 wireless devices are identified in the alarm system by the names known from the ABAX system.

For some wireless devices, you can select whether the device will take up one or two positions (channels) on the list of devices. If you select one position for the ABAX device:

- AMD-101 – only additional NC input will be supported,
- AMD-102 – only additional inputs (roller shutter and NC) will be supported,
- AOD-200 – only the motion detector will be supported,
- ATD-100 – you will be able to program only one temperature threshold,
- AVD-100 – only the vibration detector will be supported.

LCD Keypad

You can add wireless devices in service mode, using the NEW DEVICE function (►STRUCTURE ►HARDWARE ►EXPANDERS ►SETTINGS ►ABAX - INTEGRA ►NEW DEVICE).

When adding a device you can select the alarm system zone to which you want to assign the device. If the device takes up more than one position on the list of devices, additional zones will be assigned to the device automatically (these will be the zones following the selected one). To the outputs, the device is assigned automatically.

1. Start the NEW DEVICE function.
2. When the “Device serial number:” is displayed, enter the serial number of the device being added.
3. Press #.
4. When the “Open device tamper” command is displayed, power on the device (insert the battery into the device, turn on the device power, etc.).
5. Type and serial number of the device will be displayed (if a message is displayed instead to inform you that the entered serial number is invalid or the device is already registered, press * to quit the function).
6. Press the key 1.
7. If you can select whether the device will take up one or two positions (channels) on the list of devices, a special message will inform you about it. Press the key 1 (the device will occupy 1 position) or the key 2 (the device will occupy 2 positions).
8. Use the ▼ and ▲ keys to select the zone to which you want to assign the device.
9. Press #.
10. A message will be displayed to inform you that expander identification procedure has been started.
11. When the procedure is finished, the new name of the zone / output to which the device has been assigned will be displayed. You can change that name.
12. Press #.
13. If the device occupies two or more zones / outputs, the name giving procedure is repeated for them.

DLOADX program

You can add wireless devices in the “Structure” window, “Hardware” tab, after clicking on the “Wireless System”.

The device being added is assigned to zones and outputs automatically

1. Click on the “New device” button.
2. The “New device” window will open.
3. Enter the serial number of the device being added in the “Serial number” field.
4. Power on the device (install the battery in the device, turn on the device power, etc.).

5. A message will confirm that the device has been added (unless you have entered an invalid serial number, of which the message will inform you).
 - 5.1. Device type will be displayed.
 - 5.2. A new name of the zone to which the device is to be assigned will be displayed. You can change the name. If the device occupies two or more positions on the device list, the same name will be given to the other zones. If the device is to be assigned to outputs, the outputs will be given the same name.
 - 5.3. For some devices you can select if the device is to occupy one or two positions on the list of devices.
6. Click on the “OK” button.
7. The “New device” window will close.
8. The new device will be displayed on the list of devices.

5.13.2 Removing wireless devices

LCD Keypad

You can remove a wireless device in the service mode, using the REMOVE DEVICE function (►STRUCTURE ►HARDWARE ►EXPANDERS ►SETTINGS ►ABAX - INTEGRA ►REMOVE DEVICE).

1. Start the REMOVE DEVICE function.
2. List of wireless zones will be displayed.
3. Use the ▼ and ▲ keys to select the zone to which the device you want to remove is assigned.
4. Press #.
5. Press the key 1 to confirm that you want to remove the device (pressing another key will take you back to the selection list).
6. The device will be removed. A message on the display will inform you that the expander identification function has been started.
7. After identification of the devices, you will be brought back to the list of zones to which wireless devices are assigned.

DLOADX program

You can remove a wireless device in the “Structure” window, “Hardware” tab, after clicking on the “Wireless System”.

1. Click on the list on the wireless device to be removed (if the device takes up some positions on the list, you can click on any of them).
2. Click on the “Remove device” button. The “Confirm” window will open.
3. Click on the “Yes” button. The device will be removed.

5.14 Connecting computer to the control panel

Using a computer, you can update the control panel firmware (FLASHX program), program the control panel (DLOADX program) and administer the security system (GUARDX program). Communication is encrypted. The computer can be connected to the control panel via the RS-232 port.

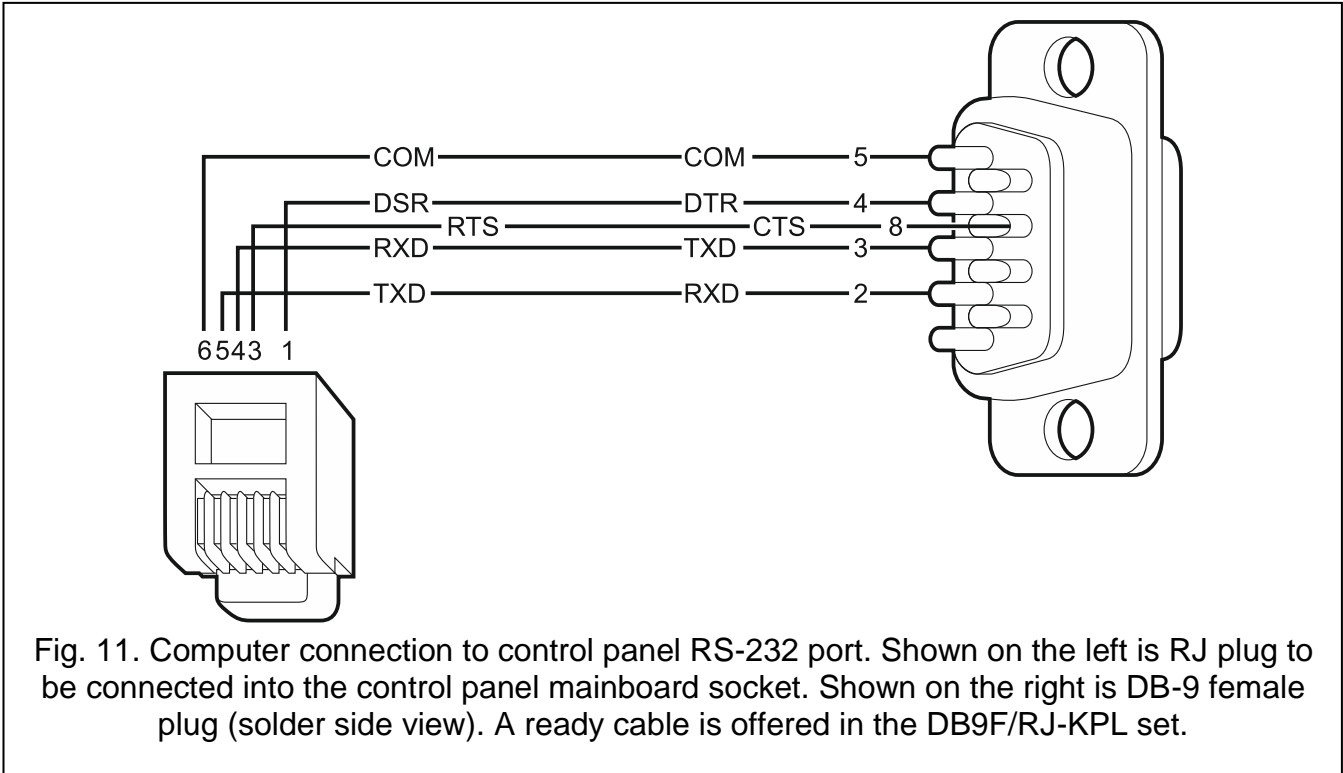

5.15 Connecting the external modem

The external modem enables remote programming of the control panel (computer with DLOADX program required) or remote administration of the security alarm system (computer with GUARDX program required). The communication is encrypted.

The control panel can work with any external modem (analog, ISDN or GSM) compatible with the Hayes AT standard and equipped with an RS-232 port.

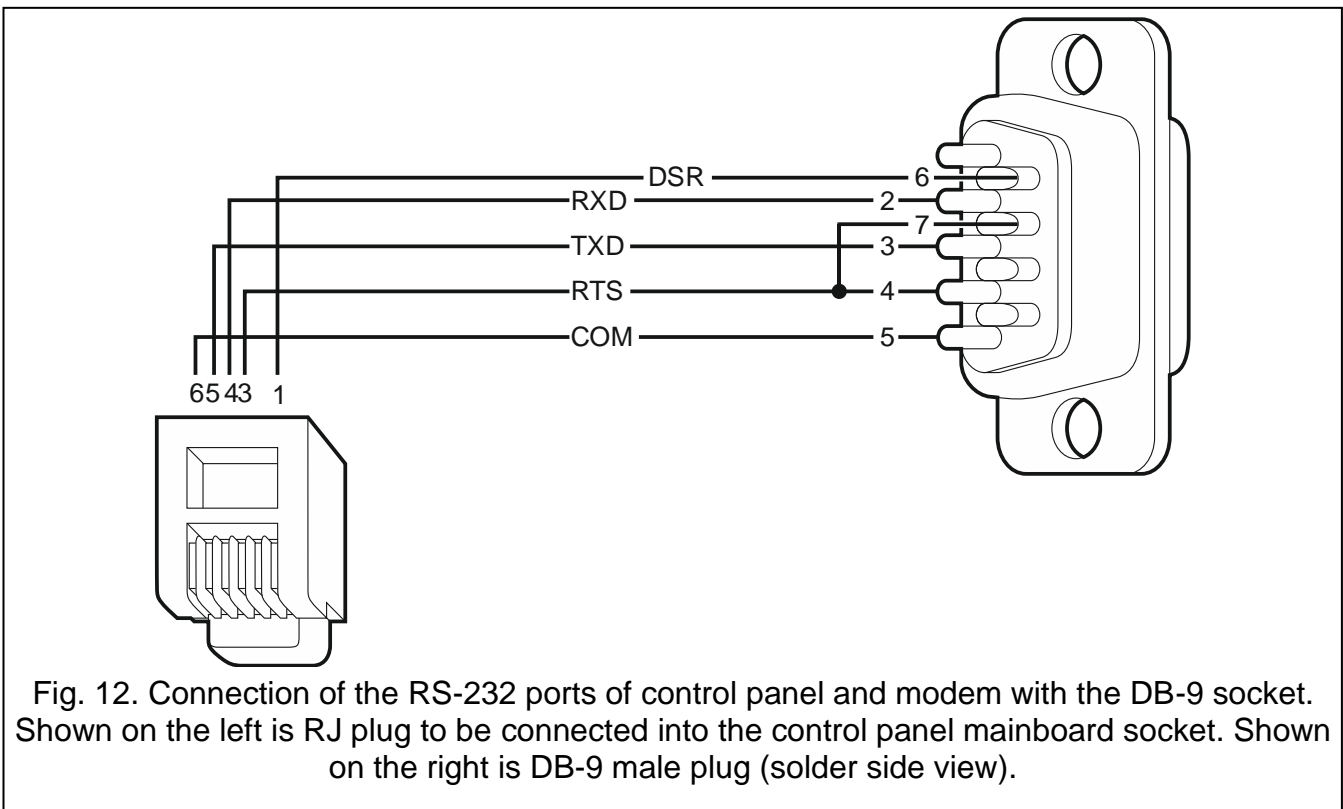

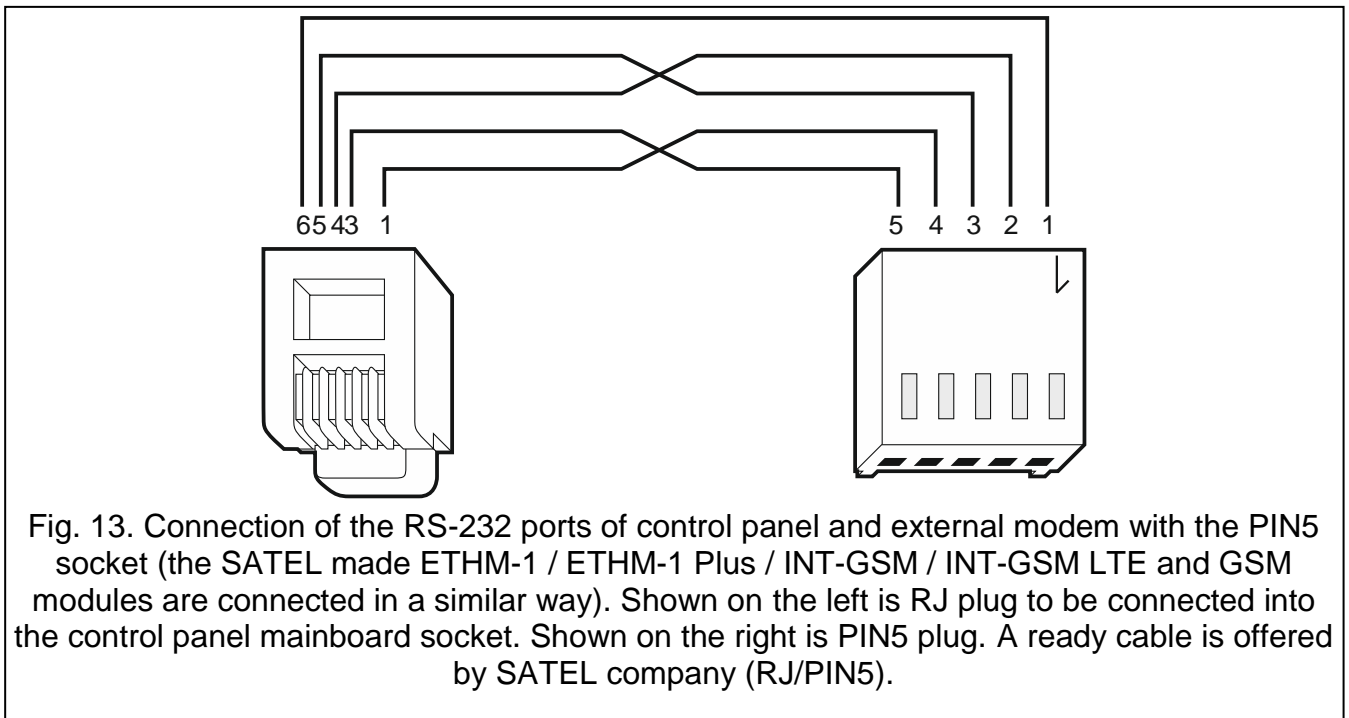

5.15.1 Configuring settings of the modem to be connected to control panel



The MDM56 and MDM56 BO modems, manufactured by SATEL, do not require any configuration. The factory settings ensure correct work with the control panel.

Before connecting to the control panel, connect the modem to the computer and, using the *Terminal* type program, set the correct operating mode.

1. Enter the `at` command – the modem should respond with “OK”. Otherwise, enter `ate1`. If the modem fails to respond, check the modem connection to the computer, and make sure that the correct COM port is selected in the *Terminal* program settings.
2. Enter the `at&v` command. The modem will present a list of parameters to be programmed (see example in Fig. 14). The parameter block saved as the “profile 0” (in Fig. 14 “STORED PROFILE 0”) should include E1 Q0 V1 X4 &D2 &S0 and S00:000. In such a case the modem is ready for operation with the control panel.
3. If any parameter is set differently, it should be modified. The parameter setting command consists of a fixed AT prefix and the desired parameter setting (e.g., if E0 V0 is included in the profile, the command for setting the proper value will be `ate1v1`, after which the modem will answer “OK”).
4. Enter the `at&w0` command to save the settings in the “profile 0”.
5. Enter the `atz` command followed by `at&v` to check that all parameters are saved correctly. The settings in ACTIVE PROFILE should be the same as in STORED PROFILE 0 (Note: Often the STORED PROFILE contains less parameters than the ACTIVE PROFILE, which is normal).



To set the S0 modem register, use the `ats0=0` command (in Fig. 14, the modem register setting is shown in a slightly different notation S00: 000).

When restarting the modem, the control panel gives the ATZ command, which sets the parameters as stored in the “profile 0”. For this reason, the current setting of the parameters mentioned in it. 2 (“ACTIVE PROFILE”) is irrelevant, but it is important that they be set properly in the “profile 0”.

```

OK
at&v
ACTIVE PROFILE:
B1 E1 L1 M1 N1 Q0 T V1 W0 X4 Y0 &C1 &D2 &G0 &J0 &K3 &Q5 &R1 &S0 &T5 &X0 &Y0
S00:000 S01:000 S02:043 S03:013 S04:010 S05:008 S06:002 S07:050 S08:002 S09:006
S10:014 S11:095 S12:050 S18:000 S25:005 S26:001 S36:007 S37:000 S38:020 S46:138
S48:007 S95:000

STORED PROFILE 0:
B1 E1 L1 M1 N1 Q0 T V1 W0 X4 Y0 &C1 &D2 &G0 &J0 &K3 &Q5 &R1 &S0 &T5 &X0
S00:000 S02:043 S06:002 S07:050 S08:002 S09:006 S10:014 S11:095 S12:050 S18:000
S36:007 S37:000 S40:104 S41:195 S46:138 S95:000

STORED PROFILE 1:
B1 E1 L1 M1 N1 Q0 T V1 W0 X4 Y0 &C1 &D2 &G0 &J0 &K3 &Q5 &R1 &S0 &T5 &X0
S00:000 S02:043 S06:002 S07:050 S08:002 S09:006 S10:014 S11:095 S12:050 S18:000
S36:007 S37:000 S40:104 S41:195 S46:138 S95:000

TELEPHONE NUMBERS:
0=                               1=
2=                               3=

OK

```

Fig. 14. Proper setting of the external modem parameters.

5.16 Connecting the printer

The control panel RS-232 port makes it possible to connect a printer provided with serial port. The control panel may print events in a "compressed" format (single event is printed in a single line containing up to 80 characters) or "extended" format, with names of zones, partitions, users and modules (then, the event is printed in two lines, when the printer with up to 80 characters per line is used; the descriptions of a single event are printed in one line with printers printing 132 characters per line).

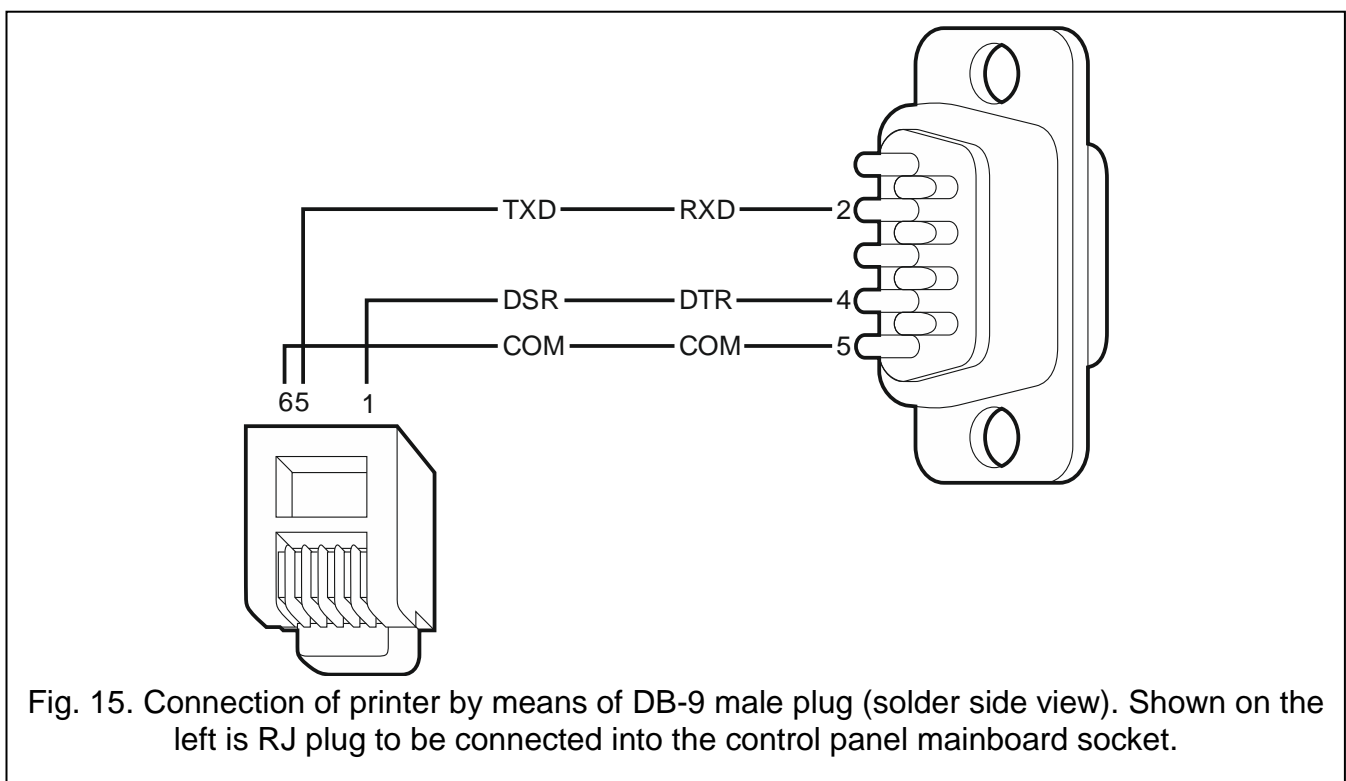
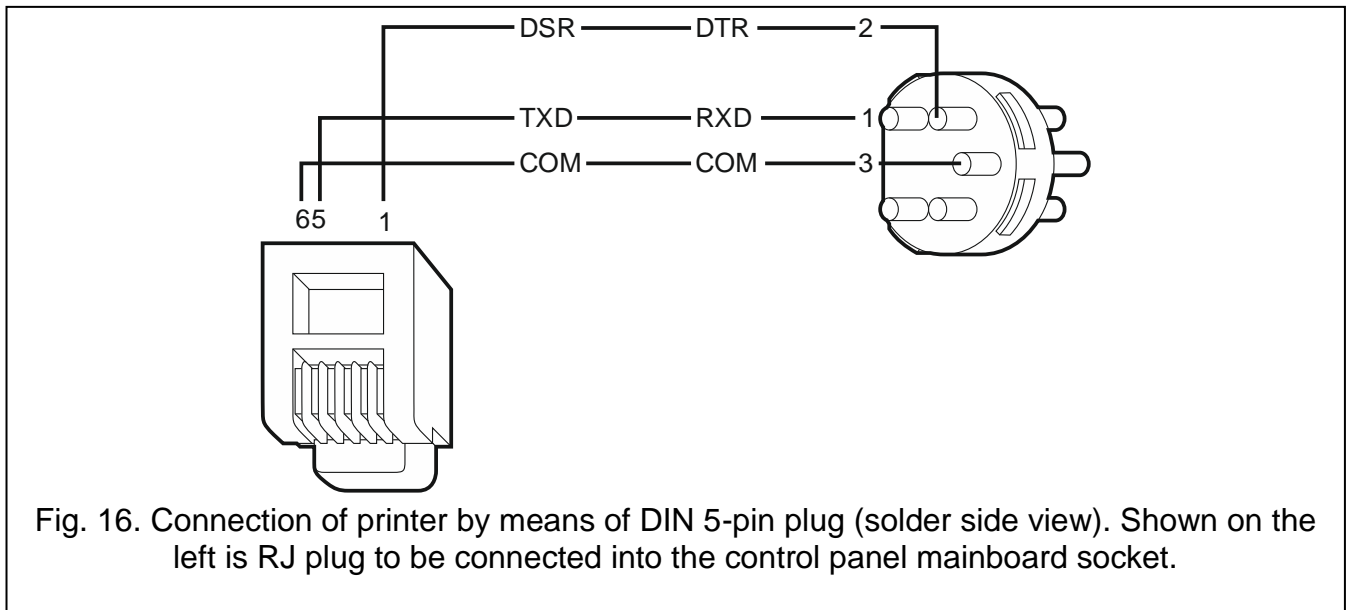

Fig. 15. Connection of printer by means of DB-9 male plug (solder side view). Shown on the left is RJ plug to be connected into the control panel mainboard socket.



6. Numeration of zones and outputs in the system

Numbers are automatically assigned to the zones and outputs:

- the hardwired zones and outputs on the control panel board are numbered from 1 to 8.
- numbers of the wireless zones and outputs supported by the INTEGRA 128-WRL control panel mainboard are set during the procedure of adding wireless devices – free and available numbers are assigned.



Numeration of wireless devices supported by the INTEGRA 128-WRL control panel mainboard need not be continuous. For example, if the system includes 8 wireless zones with numbers 17-24, to which wireless devices are assigned, and the zones 25-32 are already reserved for the expander, then adding a new wireless device will result in reservation of next 8 zones with numbers 33-40 for wireless devices. Numbering of the expander zones will remain unchanged. The same rules apply to the wireless outputs.

- the numbers of keypad zones are determined during the identification procedure, based on the keypad address (see section NUMERATION OF KEYPAD ZONES p. 16).
- the numbers of zones and outputs in expanders and ABAX 2 / ABAX system controllers are determined during the expander identification procedure. The numbering is dependent on the expansion module address in the system (zones in expansion module with a lower address will be given lower numbers than the zones in expansion module with a higher address).



The control panel reserves 8 zones in the system for each identified expander. The exceptions are the INT-ADR / CA-64 ADR expander and the ABAX 2 / ABAX controllers, for which up to 48 zones can be reserved. In case of the INT-ADR / CA-64 ADR expander, the number of reserved zones depends on the number of detectors with installed CA-64 ADR MOD module, which are connected to it. In case of the ABAX 2 / ABAX system controller, the number of reserved zones depends on the number of registered wireless devices. In both cases, the number of reserved zones is a multiple of 8.

The DLOADX program allows you to change the numeration of zones and outputs in expanders (“Structure” window, “Hardware” tab, “Advanced” button for the selected

expander). The changes in numeration will only be valid until you start the expander identification function again.

7. Replacing the battery on control panel mainboard

It is recommended that the status of clock and RAM memory backup battery be checked e.g. during periodical inspections, at least every 5 years. The battery life depends on:

- temperature,
- humidity,
- time during which the control panel power supply is off,
- battery self-discharge.

If the battery is low, it must be replaced with a new one of the same type (CR1220).



Be particularly careful during replacement of the battery. The manufacturer is not liable for the consequences of incorrect installation of the battery.

Replace the battery when the control panel power supply (main or backup) is on. If you remove the battery when the control panel power supply is off, the data stored in the RAM memory (event log, user data, clock settings) will be lost.

8. Specifications

8.1 Control panel

Supply voltage	18 V AC \pm 15%, 50-60 Hz
Recommended transformer	40 VA
Standby current consumption from AC mains.....	120 mA
Maximum current consumption from AC mains	300 mA
Standby current consumption from battery	280 mA
Maximum current consumption from battery	600 mA
Battery failure voltage threshold.....	11 V \pm 10%
Battery cut-off voltage	10.5 V \pm 10%
Battery charging current.....	400/800 mA
Power supply output current	2 A
Power supply output voltage range.....	10.5... 14 V DC
Current-carrying capacity, high-current programmable outputs	2 A \pm 10%
Current-carrying capacity, low-current programmable outputs.....	50 mA
Current-carrying capacity, +KPD output.....	0.5 A \pm 10%
Current-carrying capacity, +EX output	0.5 A \pm 10%
Current-carrying capacity, AUX output.....	0.5 A \pm 10%
ABAX system operating frequency band	868.0 MHz \div 868.6 MHz
Radio communication range (in open area)	up to 500 m
Number of supported wireless devices	48
Number of supported APT-200 / APT-100 keyfobs.....	248
Hardwired programmable zones	8
Maximum number of programmable zones.....	128

Hardwired programmable outputs.....	8
Maximum number of programmable outputs	128
Power supply outputs.....	3
Communication buses	1+1
Keypads.....	up to 8
Expansion modules	up to 32
Objects (subsystems)	8
Partitions.....	32
Telephone numbers for messaging	16
Voice messages	16
Text messages	64
Users + Masters.....	240 + 8
Timers.....	64
Event log.....	21503
Security grade according to EN50131	Grade 2
Environmental class according to EN50130-5	II
Operating temperature range.....	-10...+55 °C
Maximum humidity	93±3%
Electronics board dimensions	192 x 106 mm
Enclosure dimensions (OPU-3P)	324 x 382 x 108 mm
Weight (incl. enclosure and accessories).....	2130 g

8.2 INT-KLCD keypad

Supply voltage	12 V DC ±15%
Standby current consumption	17 mA
Maximum current consumption	101 mA
Environmental class according to EN50130-5	II
Operating temperature range.....	-10...+55 °C
Maximum humidity	93±3%
Enclosure dimensions.....	140 x 126 x 26 mm
Weight.....	231 g

8.3 INT-KLCDR keypad

Supply voltage	12 V DC ±15%
Standby current consumption	60 mA
Maximum current consumption	156 mA
Environmental class according to EN50130-5	II
Operating temperature range.....	-10...+55 °C
Maximum humidity	93±3%
Enclosure dimensions.....	140 x 126 x 26 mm
Weight.....	236 g

8.4 INT-KLCDL keypad

Supply voltage	12 V DC ±15%
Standby current consumption	61 mA

Maximum current consumption	147 mA
Environmental class according to EN50130-5	II
Operating temperature range	-10...+55 °C
Maximum humidity	93±3%
Enclosure dimensions	145 x 115 x 26 mm
Weight.....	217 g

8.5 INT-KLCDS keypad

Supply voltage	12 V DC ±15%
Standby current consumption	33 mA
Maximum current consumption	151 mA
Environmental class according to EN50130-5	II
Operating temperature range	-10...+55 °C
Maximum humidity	93±3%
Enclosure dimensions	114 x 94 x 23.5 mm
Weight.....	141 g

8.6 INT-KLCDK keypad

Supply voltage	12 V DC ±15%
Standby current consumption	30 mA
Maximum current consumption	110 mA
Environmental class according to EN50130-5	II
Operating temperature range	-10...+55 °C
Maximum humidity	93±3%
Enclosure dimensions	160 x 132 x 29 mm
Weight.....	317 g

8.7 INT-KLFR keypad

Supply voltage	12 V DC ±15%
Standby current consumption	60 mA
Maximum current consumption	110 mA
Environmental class according to EN50130-5	II
Operating temperature range	-10...+55 °C
Maximum humidity	93±3%
Enclosure dimensions	145 x 143 x 25 mm
Weight.....	346 g

9. Manual update history

Date	Firmware version	Introduced changes
2013-08	1.12	<ul style="list-style-type: none"> Information on the capability to report events via Ethernet using the UDP protocol has been added (p. 4). Information on the new INT-TSG keypad has been added (p. 5). Information on the new INT-AV module has been added (pp. 9, 14 and 18). Note on clock / RAM backup battery has been modified (p. 12).

2013-12	1.12	<ul style="list-style-type: none"> • Information on the capability to report events by means of GPRS using the UDP protocol has been added (p. 4). • Information on the INT-TSI keypad has been added (p. 5). • Information on the INT-KLFR keypad has been added (p. 5 and 34). • Information on the INT-RS Plus module has been added (p. 7).
2014-10	1.13	<ul style="list-style-type: none"> • Information on new ETHM-1 Plus module has been added (p. 6 a.o.). • Information on new INT-SF module has been added (p. 7). • Information on new INT-E module has been added (p. 7). • Information on new INT-ADR module has been added (p. 7). • Information on new INT-O module has been added (p. 7). • Information on new INT-PP module has been added (p. 7). • Information on new ACU-120 module has been added (p. 7 a.o.). • Information on new ACU-270 module has been added (p. 7 a.o.). • Information on new INT-KNX-2 module has been added (p. 9). • Note about operation of outputs when writing data to FLASH memory and when STARTER program is running has been added (p. 10).
2015-10	1.14	<ul style="list-style-type: none"> • Information on the INT-TSH keypad has been added (s. 5).
2016-04	1.15	<ul style="list-style-type: none"> • Information on AOD-200 detector has been added (p. 9 and 26). • Note on checking the battery status has been added (p. 12).
2017-05	1.17	<ul style="list-style-type: none"> • Information on AOCD-250 detector has been added (p. 9). • Information on ASD-150 detector has been added (p. 9). • Information that you can define whether the AMD-101 detector is to occupy one or two positions on the list of wireless devices has been added (s. 26).
2018-06	1.18	<ul style="list-style-type: none"> • Information about reporting, messaging and programming in section "Features" has been modified (p. 3). • Information on the new INT-GSM module has been added: (p. 6). • Section "Replacing the battery on control panel mainboard" has been added (p. 32).
2019-05	1.19	<ul style="list-style-type: none"> • Information about ABAX 2 system devices has been added. • Information about wireless keypads has been added (p. 6). • Information about ACU-220 controller has been added (p. 7). • Information about ACU-280 controller has been added (p. 7). • List of supported ABAX 2 devices has been added (p. 9). • Section "Installation of wireless devices" has been modified (p. 24). • Section "Replacing the battery on control panel mainboard" has been modified (p. 32).
2021-08	1.20	<ul style="list-style-type: none"> • Information on the INT-GSM LTE module has been added. • Information on the INT-TSG2 and INT-TSH2 keypads has been added.