

Keypad with touch keys
INT-KSG2R

Firmware version 2.03

EN

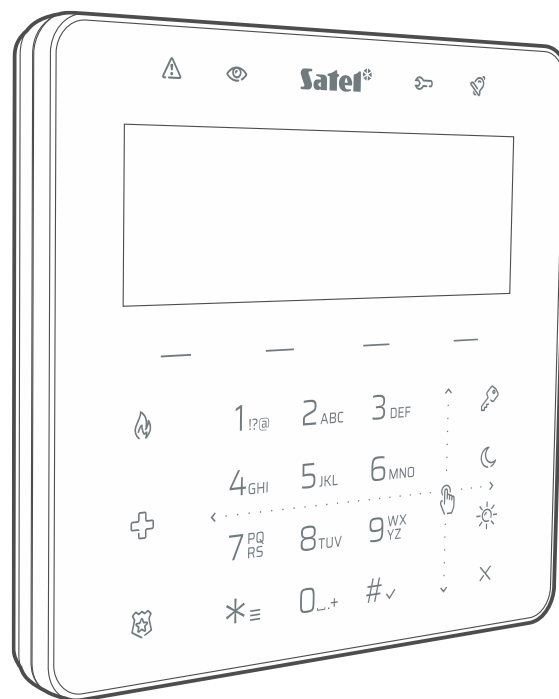

CE



INSTALLER MANUAL

int-ksg2r_i_en 04/24

Satel®

SATEL sp. z o.o. • ul. Budowlanych 66 • 80-298 Gdańsk • POLAND
tel. +48 58 320 94 00
www.satel.pl

IMPORTANT

The keypad should be installed by qualified personnel.

Read carefully this manual before proceeding to installation.

Changes, modifications or repairs not authorized by the manufacturer shall void your rights under the warranty.

SATEL aims to continually improve the quality of its products, which may result in changes in their technical specifications and software. The current information on the introduced modifications is available on our website.

Please visit us at:
<https://support.satel.pl>

Hereby, SATEL sp. z o.o. declares that the radio equipment type INT-KSG2R is in compliance with Directive 2014/53/EU. The full text of the EU declaration of conformity is available at the following internet address: www.satel.pl/ce

Signs in this manual



Caution – information on the safety of users, devices, etc.



Note – suggestion or additional information.

CONTENTS

1. Features	2
2. Using the touch keys	3
Touch	3
Touch and hold	3
Swipe up	4
Swipe down.....	4
Swipe right	5
Swipe left	5
3. Installation	5
3.1 Description of terminals	7
3.2 Address setting	8
3.2.1 Address setting in the service mode	8
Keypad in the INTEGRA system	8
Keypad in the PERFECTA 64 M system	8
3.2.2 Address setting without starting the service mode	9
3.3 Identification	9
3.3.1 Keypad identification in the INTEGRA system	9
Keypad.....	9
DLOADX program	9
3.3.2 Keypad identification in the PERFECTA 64 M system	10
Keypad.....	10
PERFECTA SOFT PROGRAM.....	10
4. Programming.....	10
4.1 Keypad in the INTEGRA system.....	10
4.1.1 Programming in the DLOADX program	10
4.1.2 Programming from the keypad	10
4.1.3 Encryption settings for the MIFARE cards.....	11
4.1.4 Keypad settings.....	12
Keypad.....	12
Volume/filter	14
Macro Commands.....	15
Status screen (Screensaver).....	19
EOL resistance value	21
State inspections.....	23
User functions definition	24
Proximity cards.....	24
4.2 Keypad in the PERFECTA 64 M system	25
4.2.1 Programming in the PERFECTA SOFT program.....	25
4.2.2 Programming from the keypad	26
4.2.3 Keypad settings.....	26
Screensaver.....	28
Macro command settings	30
5. Updating the keypad firmware.....	33
6. Specifications	34
7. Manual update history	34

The INT-KSG2R keypad with touch keys is used to operate and program control panels of the INTEGRA series (firmware version 1.21 or newer) and the PERFECTA 64 M control panels.

This manual applies to the keypad with electronics version 1.4 (or newer).

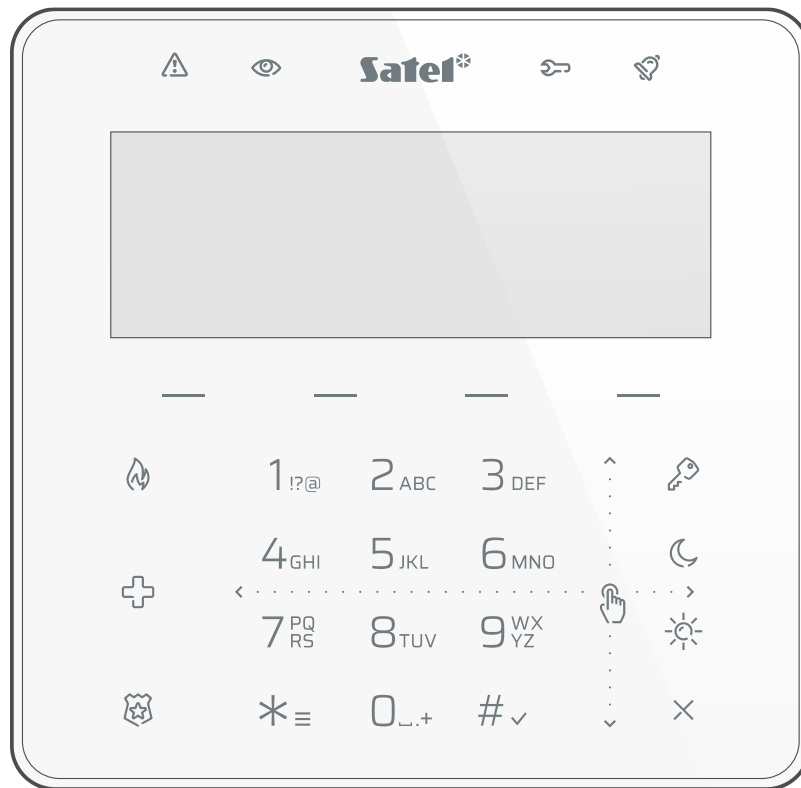

Fig. 1. INT-KSG2R keypad.

1. Features

- Large graphic display with backlight.
- Customizable screensaver.
- Touch keypad with backlight:
 - 12 keys to enter data, with labels according to telephone standard,
 - 4 function keys (INTEGRA: to select functions; PERFECTA 64 M: to arm / disarm the system),
 - 3 keys to generate alarm (fire / medical emergency / panic),
 - 4 keys to run macro commands,
 - swipe gesture (menu navigation).
- Alarm system control by means of macro commands to facilitate the running of functions.
- Built-in 13.56 MHz MIFARE proximity card reader:
 - Ultralight,
 - Classic,
 - DESFire (EV1 / EV2 / EV3).
- LEDs indicating the system state.
- Built-in sounder.

- 2 programmable hardwired zones (supported in the INTEGRA system):
 - support for NO and NC type detectors, as well as roller shutter and shock detectors,
 - support for EOL, 2EOL and 3EOL configuration (3EOL for the INTEGRA Plus control panels),
 - programmable end-of-line resistor value.
- Capability to connect to the RS-485 bus (firmware update via the bus).
- Tamper protection against enclosure opening and removal from mounting surface.



The MIFARE® cards are supported if the keypad is connected to the INTEGRA series control panel.

2. Using the touch keys

You can use the gestures described below.

Touch

Touch the key with your finger.

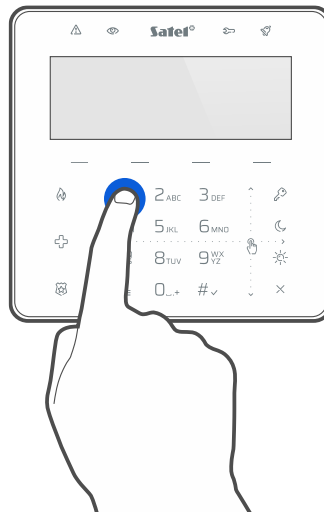

Touch and hold

Touch the key and hold for 3 seconds.

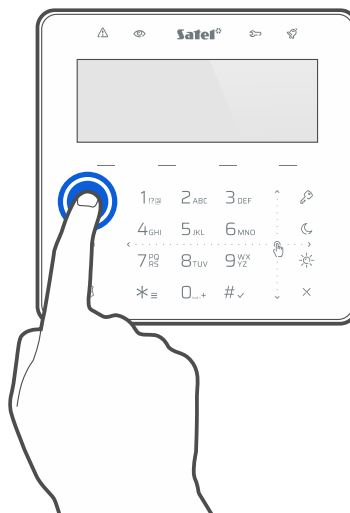

Swipe up

Touch the keys area and slide your finger up to:

- scroll up the list,
- move the cursor up or left (depending on the function),
- clear the character to the left of the cursor when editing,
- exit the graphic mode.



Swipe down

Touch the keys area and slide your finger down to:

- scroll down the list,
- move the cursor down,
- change the letter case when editing,
- exit the graphic mode.



Swipe right

Touch the keys area and slide your finger right to:

- enter the submenu,
- start a function,
- move the cursor right,
- enter the graphic mode.

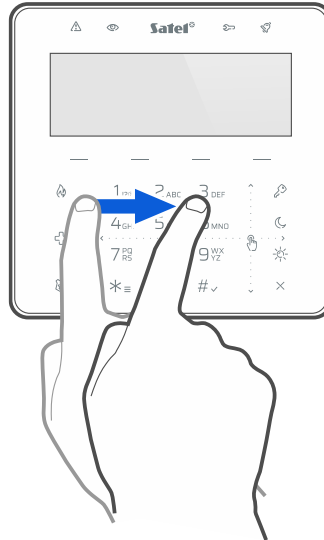

Swipe left

Touch the keys area and slide your finger left to:

- exit the submenu,
- move the cursor left,
- enter the graphic mode.

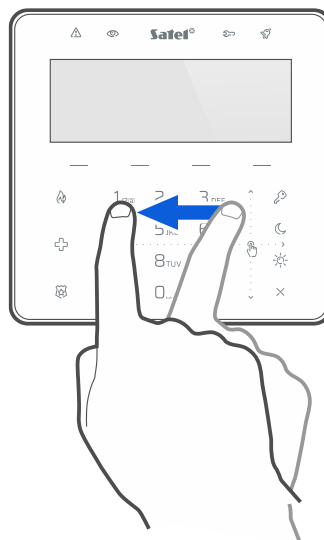

3. Installation



Disconnect power before making any electrical connections.

The keypad is designed for indoor installation. The place of installation should be readily accessible to the system users.

1. Open the keypad enclosure (Fig. 2). The enclosure opening tool, shown in the illustration, is included in the keypad delivery set.

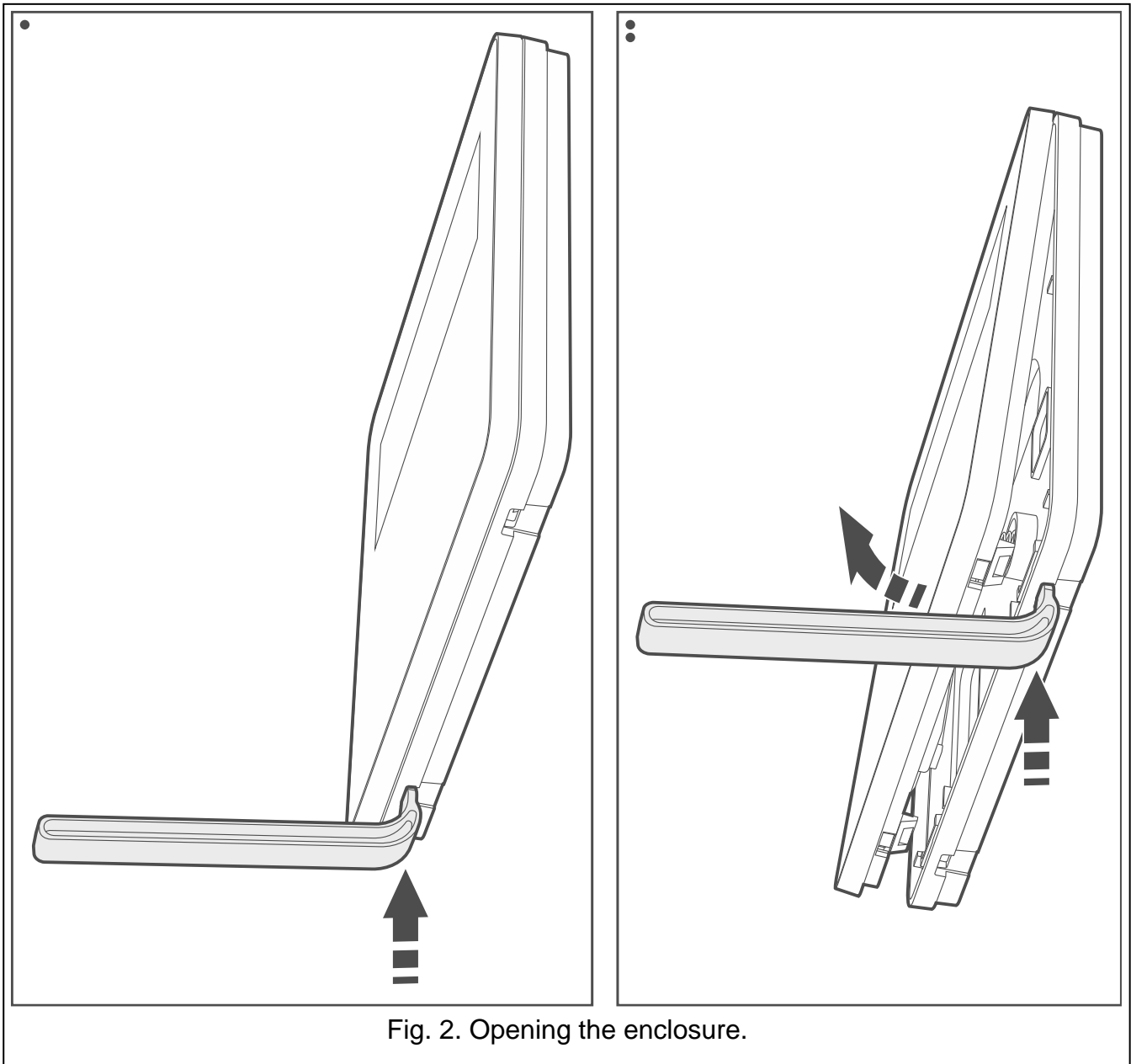

Fig. 2. Opening the enclosure.

2. Place the enclosure base against the wall and mark the location of the mounting holes (Fig. 3).
3. Drill the holes in the wall for wall plugs (anchors).
4. Pass the cables through the opening in the enclosure base (Fig. 3).
5. Using wall plugs (anchors) and screws, secure the enclosure base to the wall. Proper wall plugs must be selected for the type of mounting surface (different for concrete or brick wall, different for plaster wall, etc.).
6. Connect the DTA, CLK and COM keypad terminals to the appropriate terminals of the control panel communication bus (Fig. 4). To make the connection, use an unshielded non-twisted cable. If you use the twisted-pair type of cable, remember that CLK (clock) and DTA (data) signals must not be sent through one twisted-pair cable. The wires must be run in one cable. The length of wires must not exceed 300 m.

7. If you wish to connect any detectors to the Z1 and Z2 zones, connect the wires to the terminals. Connect the detectors in the same way as to the control panel onboard zones (**use the keypad COM terminal**).
8. Connect the power wires to the +12V and COM terminals. The keypad can be powered directly from the control panel or from an additional power supply.
9. Place the front panel onto the catches, snap close the enclosure.

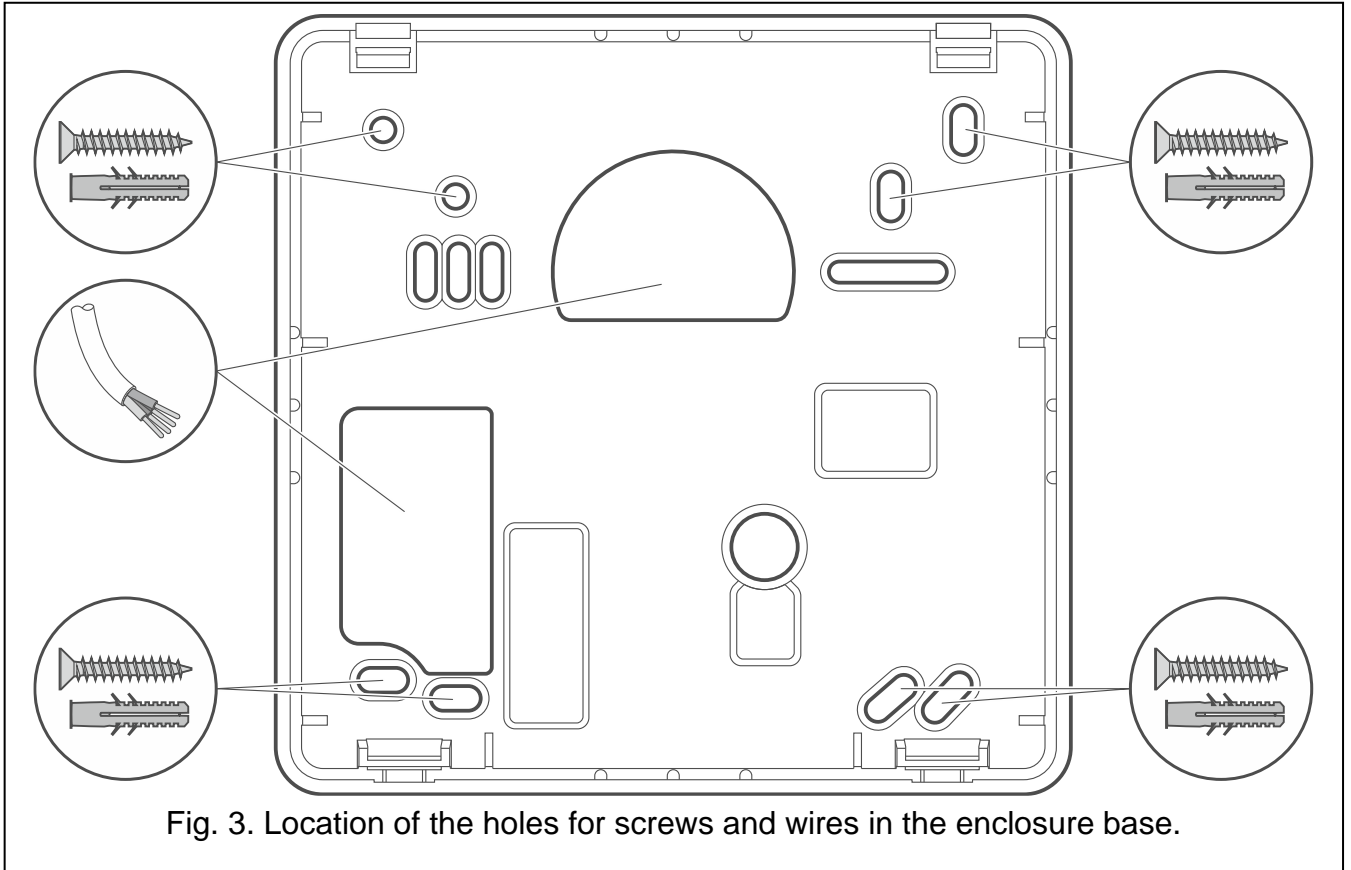

Fig. 3. Location of the holes for screws and wires in the enclosure base.

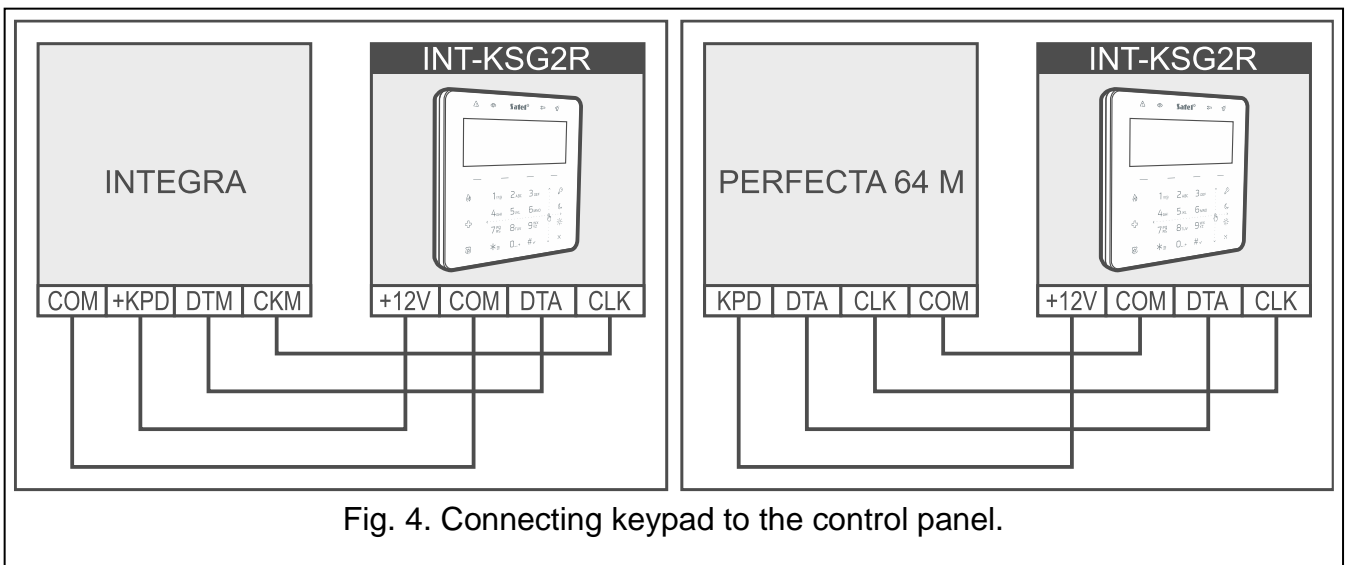

Fig. 4. Connecting keypad to the control panel.

3.1 Description of terminals

- +12V** - power input.
- COM** - common ground.
- DTA** - data.

- CLK** - clock.
RSA, RSB - RS-485 bus.
OC1, OC2 - terminals provided for future applications.
Z1, Z2 - zones.

3.2 Address setting

Each keypad connected to the control panel must have its individual address set in it. By default, address 0 is set in the keypad.

Set an address depending on the control panel to which the keypad is connected:

- INTEGRA 24 / INTEGRA 32 / PERFECTA 64 M control panel: in the range from 0 to 3,
- other INTEGRA or INTEGRA Plus control panel: in the range from 0 to 7.



When started with factory default settings, the control panel will support all keypads connected to the bus, irrespective of the addresses set in them. Otherwise, keypads with identical addresses are not supported.

If the keypad is connected to the INTEGRA series control panel, the address set in the keypad determines the numbers to be given to the keypad zones (see the installer manual for the INTEGRA or INTEGRA Plus control panels).

You can set the address:

- after starting the service mode. The address setting function is available in the service menu. You can start it from any keypad supported by the control panel. After starting it, you can set the address in all wired keypads.
- without starting the service mode. When operation of the keypads is blocked and it is impossible to start the service mode (e.g. the address of the new keypad and the address of the keypad installed previously are the same), it is the only way to set the address.

3.2.1 Address setting in the service mode

Keypad in the INTEGRA system

1. Enter the **service code** (by default: 12345) and touch $\star \equiv$. The user menu will be displayed.
2. Touch $\text{9}_{\text{YZ}}^{\text{WX}}$. The service menu will be displayed.
3. Start the function *Keypads addr.* (►Structure ►Hardware ►Identification ►Keypads addr.). All wired keypads will display the message: *This LCD address (n, 0-x) [n – keypad address; 0-x – range of supported addresses]*.
4. Enter the new keypad address and touch $\star \equiv$. The keypad will restart. The service menu will be displayed.



If you fail to set the new address within 2 minutes after you started the Keypads addr. function, the function will be terminated automatically and the keypad will restart.

Keypad in the PERFECTA 64 M system

1. Enter the **service code** (by default: 12345) and touch $\star \equiv$. The user menu will be displayed.
2. Find the *Service mode* function (use the swipe up gesture) and touch $\# \checkmark$. The service menu will be displayed.
3. Touch $\text{2}_{\text{ABC}} \text{0}_{\text{L}} \text{+} \# \checkmark$ to start the *20.Kpd.address* function. All wired keypads will display the message: *This LCD address (n, 0-3) [n – keypad address; 0-3 – range of supported addresses]*.

4. Enter the new keypad address and touch $\star \equiv$. The keypad will restart. The service menu will be displayed.



If you fail to set the new address within 2 minutes after you started the 20.Kpd.address function, the function will be terminated automatically and the keypad will restart.

3.2.2 Address setting without starting the service mode

1. Power off the keypad.
2. Disconnect wires from the keypad CLK and DTA terminals.
3. Short the CLK and DTA keypad terminals.
4. Power on the keypad. Information about the set address will be displayed.
5. Enter the new keypad address and touch $\star \equiv$. The keypad will restart. Information about the set address will be displayed.
6. Power off the keypad.
7. Open the CLK and DTA keypad terminals.
8. Connect the wires to the CLK and DTA keypad terminals.
9. Power on the keypad.

3.3 Identification

The devices connected to the control panel communication bus are supported correctly only if they are identified. Device identification is required at the first start-up of the control panel, and each time when a new device is added or address is changed in a device supported by the control panel. To run the identification function you can use the keypad or the DLOADX (INTEGRA system) / PERFECTA SOFT (PERFECTA 64 M system) program.



Disconnecting an identified device from the communication bus will generate the tamper alarm.

3.3.1 Keypad identification in the INTEGRA system

Keypad

1. Enter the **service code** (by default: 12345) and touch $\star \equiv$. The user menu will be displayed.
2. Touch 9_{YZ}^{WX} . The service menu will be displayed.
3. Start the *LCD keypads id.* function. (Structure ► Hardware ► Identification ► LCD keypads id.). The *LCD keypads identification...* message will be displayed.
4. When identification is completed, information about the devices connected to the keypad bus will be displayed. Touch $\# \checkmark$ to return to menu.

DLOADX program



1. Click  in the main menu. The “Structure” window will be displayed.
2. Click on the “Hardware” tab.
3. Click on the “Keypads” branch.
4. Click “Keypads identification”. The identification function will start.
5. When a window will be displayed with information that the identification is complete, click “OK”.

3.3.2 Keypad identification in the PERFECTA 64 M system

Keypad

1. Enter the **service code** (by default: 12345) and touch *≡. The user menu will be displayed.
2. Find the *Service mode* function (use the swipe up gesture) and touch #✓. The service menu will be displayed.
3. Touch 2_{ABC} 1_{!@} #✓ to start the *21.Identificat.* function. The *Please wait...* message will be displayed.
4. When identification is complete, the total number of devices connected to the communication bus and the communication connector will be displayed. Touch *≡ to return to menu.

PERFECTA SOFT PROGRAM

1. Click on the “Hardware” tab.
2. Click “Mainboard”.
3. Click “Detect connected modules”.
4. When identification is complete, a window with the total number of devices connected to the communication bus and the communication connector will be displayed.



4. Programming

4.1 Keypad in the INTEGRA system

You can configure all the keypad settings from the computer with the DLOADX program installed. Not all settings can be configured using the keypad. Names of parameters and options from the DLOADX program are used in this manual. When a parameter or option is described, its name from the LCD keypad is shown in square brackets.

4.1.1 Programming in the DLOADX program

Required version of the DLOADX program: 1.22.002 (or newer).

1. Click  in the main menu. The “Structure” window will be displayed.
2. Click on the “Hardware” tab.
3. Click on the “Keypads” branch.
4. Program the encryption settings for the MIFARE cards.
5. Click on the name of the keypad whose settings you want to configure.
6. Configure the keypad settings.
7. Click  in the main menu to save changes to the control panel. For settings stored in the keypad, click on the “Write” button.

4.1.2 Programming from the keypad

1. Enter the **service code** (by default: 12345) and touch *≡. The user menu will be displayed.
2. Touch 9_{WX}_{YZ}. The service menu will be displayed.
3. Start the *Settings* function (►Structure ►Hardware ►LCD keypads ►Settings).
4. Find the keypad whose settings you want to configure (swipe up or down) and touch #✓.

5. Configure the keypad settings. For instructions on how to edit data, please refer to the control panel programming manual (instead of arrow keys, use the swipe gesture).

4.1.3 Encryption settings for the MIFARE cards

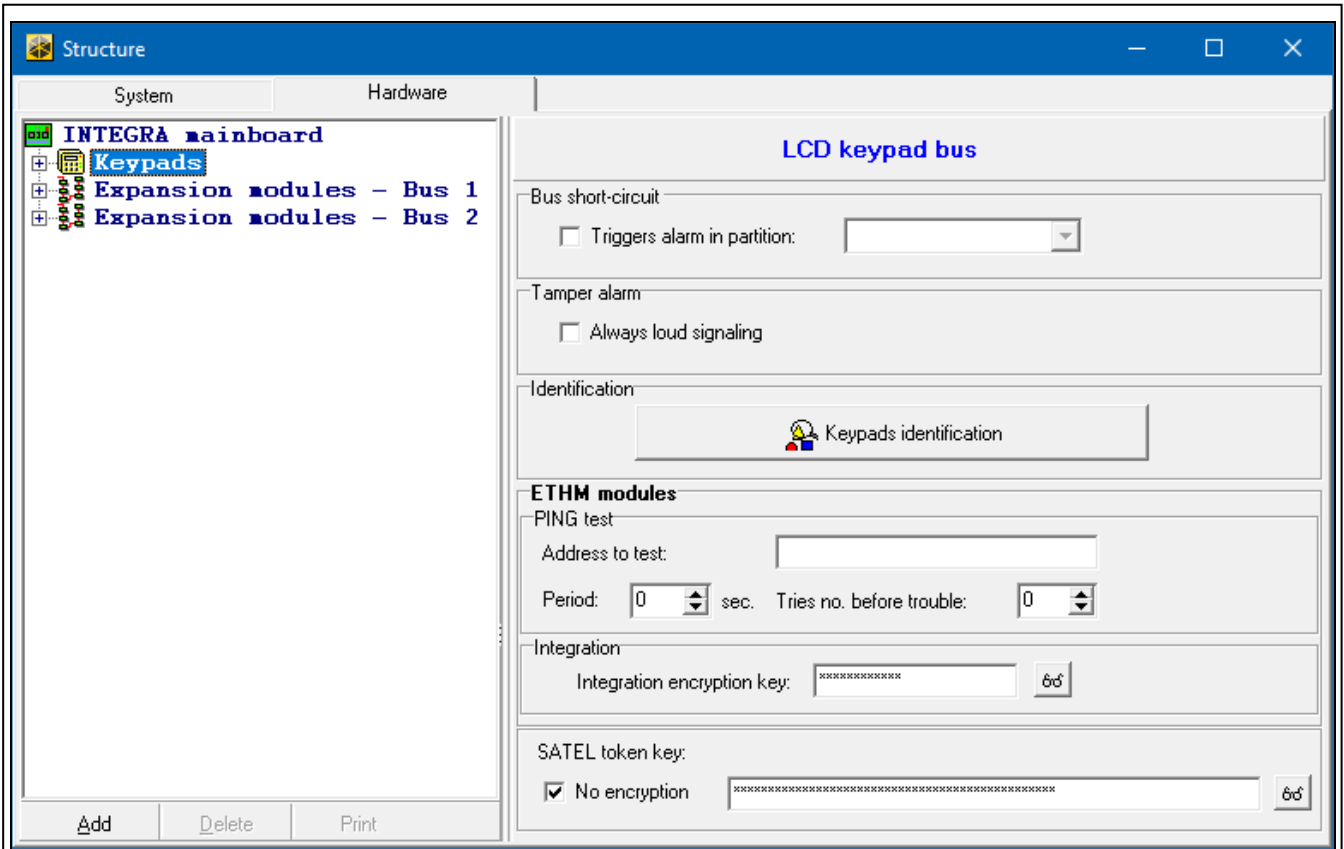

Fig. 5. DLOADX program: keypad in the INTEGRA system – keypad bus settings (example).

SATEL token key – card number access key for the MIFARE card. It is used for reading encrypted card numbers. Click to view the key. Factory key: 00:00:00:00:00:00:00:00:00:00:00:00:00:00:00:00 (no key – reader only reads the card’s unencrypted factory serial number (CSN)).

No encryption – if this option is enabled, the reader only reads the card’s unencrypted factory serial number (CSN). There is no need to program the cards but such cards are not secured against copying.

To write encrypted numbers to cards, the SO-PRG programmer and the CR SOFT program by SATEL are required.

The key in the DLOADX program must be the same as the key used in the CR SOFT program to write the card number.

For security reasons, we recommend using DESFire cards with encrypted card numbers.

If you enable the No encryption option after you have programmed the key, the key will be cleared.

The card number’s 5 bytes are used. If the number is shorter, zeros will be added to complete the number. If the number is longer, the extra bytes will not be used.

4.1.4 Keypad settings

Keypad

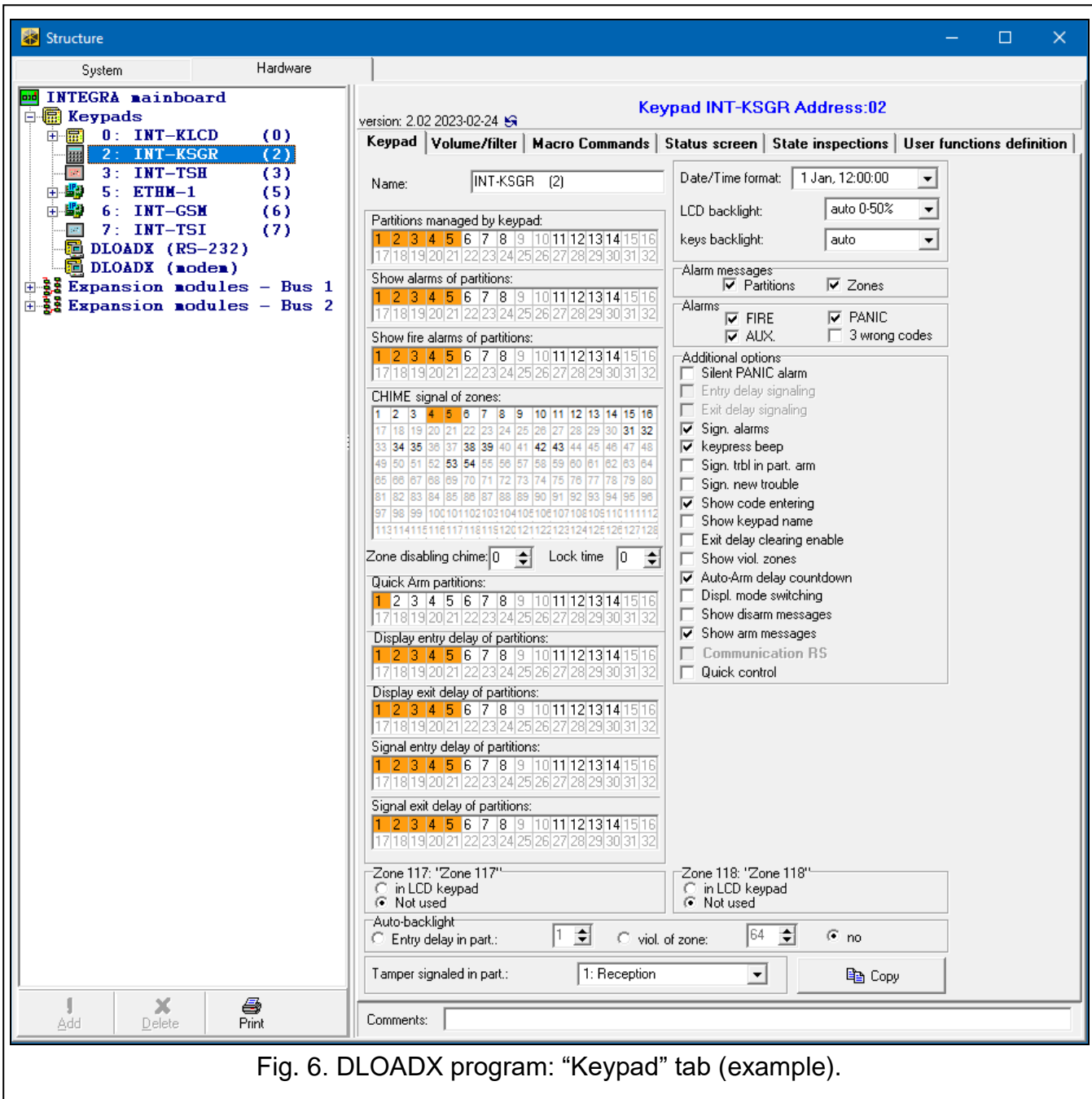

Fig. 6. DLOADX program: "Keypad" tab (example).

Name – individual name of the keypad (up to 16 characters).

Partitions managed by keypad [Partitions] – partitions which can be armed / disarmed or in which an alarm may be cleared by using the keypad. These functions are available to the users having appropriate rights and access to these partitions.

i *The service code gives access to all partitions irrespective of which partitions are operated by the keypad.*

Show alarms of partitions [Alarms] – the keypad can signal burglary alarms from selected partitions.

Show fire alarms of partitions [Fire alarms] – the keypad can signal fire alarms from selected partitions.

CHIME signal of zones [Chime zones] – the keypad can audibly signal violation of selected zones.

Zone disabling chime [Chime bps. zone] – violation of this zone will disable the CHIME feature.



The zone 256 cannot disable the CHIME feature.

Bypass time [Chime bps. time] – time during which the CHIME signal will be disabled after the zone which disables the signaling is violated (time is counted from the zone restore). If you enter 0, the signaling will not be disabled.

Display entry delay of partitions [Show entry del.] – the keypad displays information about entry delay countdown in selected partitions.

Display exit delay of partitions [Show exit delay] – the keypad displays information about exit delay countdown in selected partitions.

Signal entry delay of partitions [Sign.entry del.] – the keypad audibly signals the entry delay countdown in selected partitions.

Signal exit delay of partitions [Sign.exit delay] – the keypad audibly signals the exit delay countdown in selected partitions.

Date/Time format [DateTime format] – mode of presentation of time and date on the display.

LCD backlight [LCD backlight] – the way the display backlight works.

Keys backlight [Keys backlight] – the way the keys backlight works.

Alarm messages

Partitions [Part.al.msg.] – if this option is enabled, messages on partition alarms are displayed (they contain the name of partition).

Zones [Zone al.msg.] – if this option is enabled, messages on alarms from zones are displayed (they contain the name of zone). The zone alarm messages have the priority.

Alarms

FIRE [Fire alarm] – if this option is enabled, the user can generate the fire alarm by touching and holding  for 3 seconds.

PANIC [Panic alarm] – if this option is enabled, the user can generate the panic alarm by touching and holding  for 3 seconds.

AUX. [Medical alarm] – if this option is enabled, the user can generate the medical alarm by touching and holding  for 3 seconds.

3 wrong codes [3 wrong codes] – if this option is enabled, entering incorrect code three times will generate the alarm.

Additional options

Silent PANIC alarm [Silent panic] – if this option is enabled, the panic alarm generated from the keypad will be a silent one, i.e. the keypad will not indicate it, there will be no audible signal, but the alarm will be reported to the monitoring station. The silent panic alarm is useful when the control panel is sending events to the monitoring station, but unauthorized persons should not be aware of the alarm being generated. This option is available when the *PANIC* option is enabled.

Sign. alarms [Alarm signal.] – if this option is enabled, the keypad will signal alarms audibly.

Keypress beep [Key sound] – if this option is enabled, touching the keys is confirmed by a beep.

Sign. trbl. in part. arm [Trbl.in p.arm.] – if this option is enabled, the  LED goes off after all partitions managed by keypad are armed. If the option is disabled, the LED goes off after just one of the partitions is armed.

Sign. new trouble [New trbl. sign.] – if this option is enabled, the keypad will audibly signal the occurrence of a new trouble (if the *Trouble memory until review* option is enabled). New trouble signaling is cleared after the troubles have been reviewed by the user.

Show code entering [Show code ent.] – if this option is enabled, entering the code is presented on the keypad screen by asterisks.

Show keypad name [Name (2nd row)] – if this option is enabled, the keypad name is presented in the lower line of the display.

Exit delay clearing enable [Fin.exit time] – if the option is enabled, the user can terminate the exit delay countdown by touching $\mathcal{G}_{YZ}^{WX} \# \checkmark$ or by touching and holding \times for 3 seconds. The exit delay time can be shortened in partitions with the *Exit delay clearing* option enabled.

Show viol. zones [Zone violation] – if this option is enabled, the name of the zone that generates the CHIME signal will be displayed when the zone is violated.

Auto-Arm delay countdown [Auto-arm delay] – if this option is enabled, the keypad informs the users about the auto-arm delay countdown in partition (message / sound).

Displ. mode switching [Displ.mode chg.] – if this option is enabled, the user can switch the keypad between the standby mode and the partition status display mode by touching and holding the \mathcal{G}_{YZ}^{WX} for 3 seconds.

Show disarm messages [Show disarming] – if this option is enabled, the keypad displays the disarming message irrespective of how the system has been disarmed. If this option is disabled, the keypad displays the disarming message only when the system has been disarmed from this keypad.

Show arm messages [Show arm] – if this option is enabled, the keypad displays the arming message. If the option is disabled, the arming message is not displayed.

Quick control [Control (8#)] – if this option is enabled, the user can start the *Control* function by touching $\mathcal{G}_{TUV} \# \checkmark$ (without entering the code).

Zone

in LCD keypad – if you select this option, the keypad zone will be supported.

Not used – if you select this option, the keypad zone will not be supported.

Auto-backlight

Entry delay in part. – if you select this option, the backlight will additionally go on if entry delay countdown starts in the selected partition.

viol. of zone – if you select this option, the backlight will additionally go on if a selected zone is violated.

no – if you select this option, the backlight will only go on if the user touches the keys.

Tamper signaled in part. [Tamper in part.] – partition where alarm will be generated in the event of keypad tamper, generating the alarm from keypad, etc.

Volume/filter

Volume – volume of the beeps generated when the keypad is used (key touch, confirmation of performed operation, etc.).

Volume – chime – volume of the beeps generated after zone violation (CHIME signaling).

Volume – entry delay – volume of the entry delay signaling.

Volume – exit delay – volume of the exit delay signaling.

Volume – fire – volume of the fire alarm signaling.

Volume – alarm – volume of the burglary, panic and medical alarm signaling.

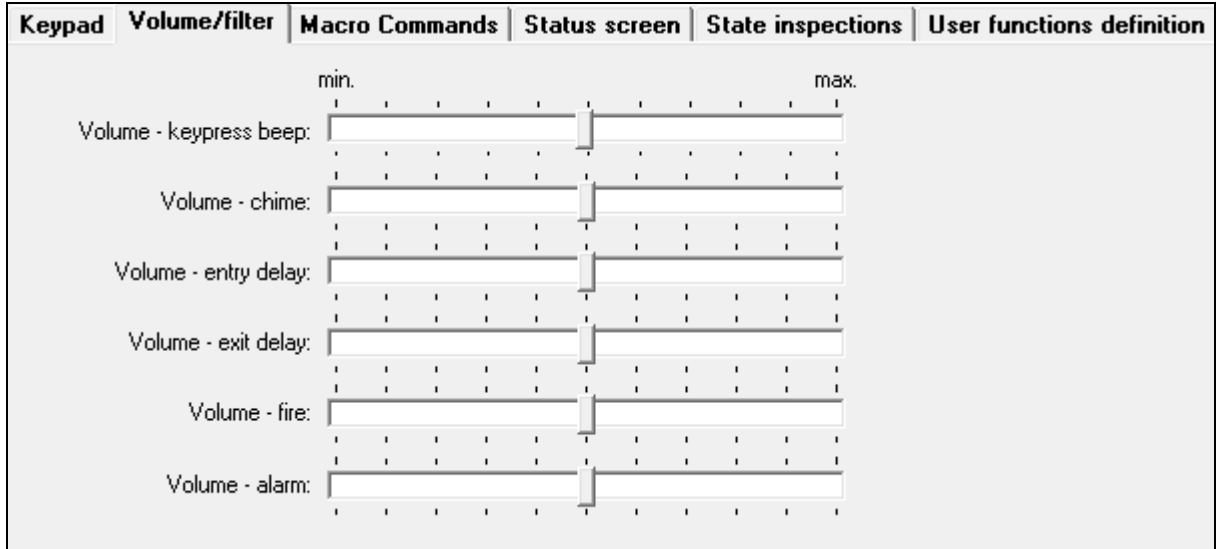



Fig. 7. DLOADX program: “Volume/filter” tab.

Macro Commands

The macro command is a sequence of actions to be performed by the control panel. The macro commands help the user to operate the alarm system. Instead of performing several operations (e.g. in order to arm the selected partitions) the user can run a macro command, and the control panel will execute the functions assigned to it.

i *The macro command settings are stored in the keypad. Therefore, before you make any changes, click on the “Read” button, and after you make the changes, click on the “Write” button (Fig. 8). The settings stored in the keypad are not read / written after clicking  /  in the main menu.*

Groups

The macro commands which are to be available to the keypad users must be assigned to one of the four groups. You can assign up to 16 macro commands to the group. The macro command groups and the macro commands assigned to them are presented in a tree form.

Name – name of the macro command group (up to 8 characters). It is presented on the bottom of the display, above the — key.

Add macro – click to add the macro command to the group. The list of available macro commands will be displayed. Click on the macro commands you want to add to the group.

Remove macro – click to delete the selected macro command from the group.

 – click to move the selected macro command down.

 – click to move the selected macro command up.

Export to file – click to export the macro command settings to a file.

Import from file – click to import the macro command settings from a file.

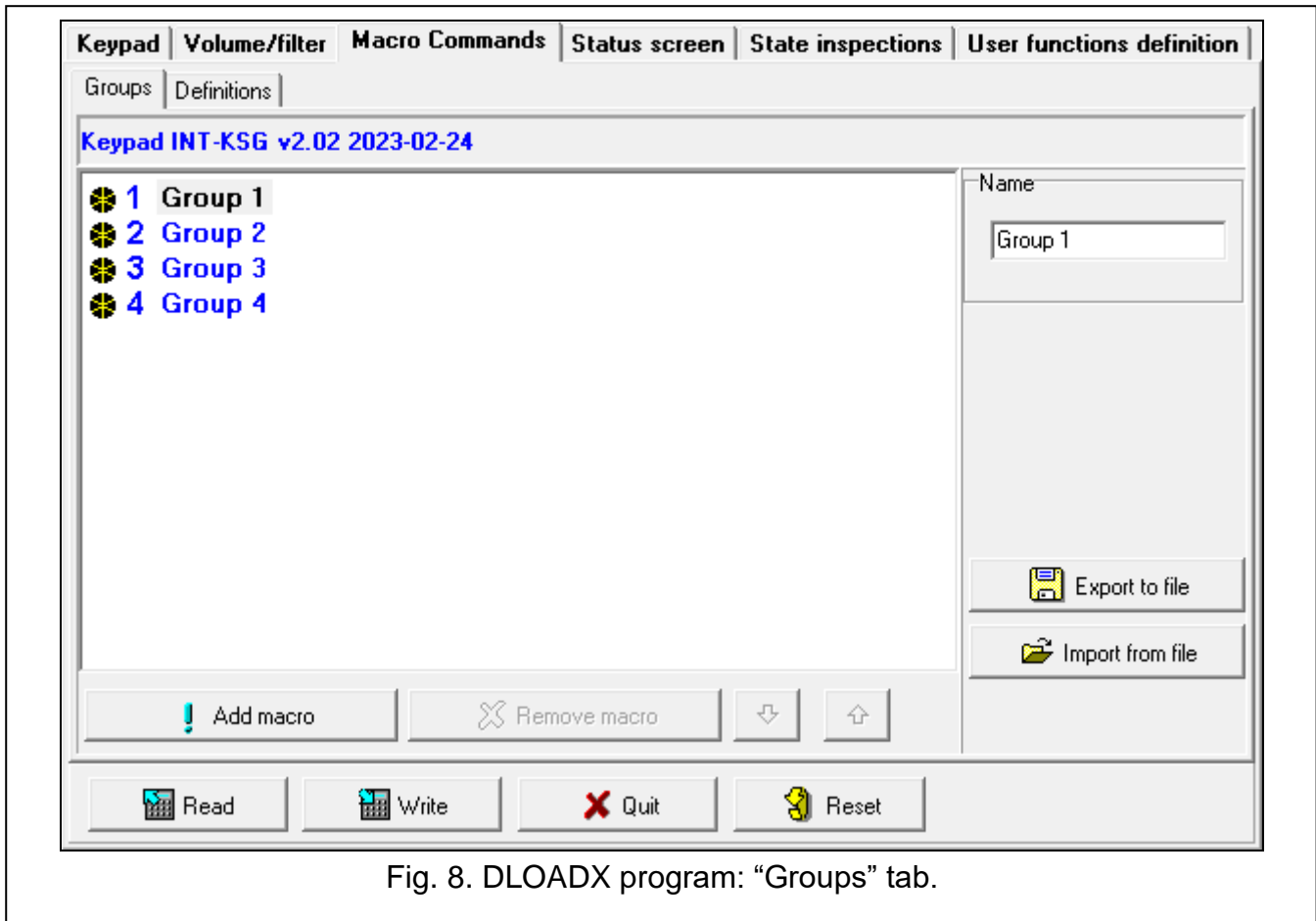

Fig. 8. DLOADX program: “Groups” tab.

Definitions

New macro – click to create a new macro command.

Remove macro – click to delete the selected macro command.

Macros import – click to open the “Macros import” window, in which you can import macros from another device that supports macro commands.

Name – individual name of the macro command (up to 16 characters).

Code – code sent to the control panel when commands contained in the macro command are executed. For execution of such commands to be possible, the code must have a suitable authority level.





If, when executing a macro command, it turns out that the code is invalid (e.g. it has been changed), the user will be asked to enter the correct code. It will be automatically saved to the keypad memory (replacing the invalid one).

Authorization required – if this option is enabled, the macro command is executed only after the user enters the code (the code entered in the “Code” field is not used).

Disabl. if armed – if this option is enabled, the macro command is not available, when any of the partitions operated by the keypad is armed.

Autoexecute – if this option is enabled and there is just one macro command in the group, the macro command will be executed instantly on touching the — key.

Commands list – commands assigned to the currently highlighted macro command. The  and  buttons allow you to change the order of commands (moving the selected command up and down).

Add – click to add to the list a new command selected in the “Command” field.

Change – click to save the changes to the command settings that were made after adding the command to the list (otherwise, the changes will not be saved).

Delete – click to remove the highlighted command from the list.

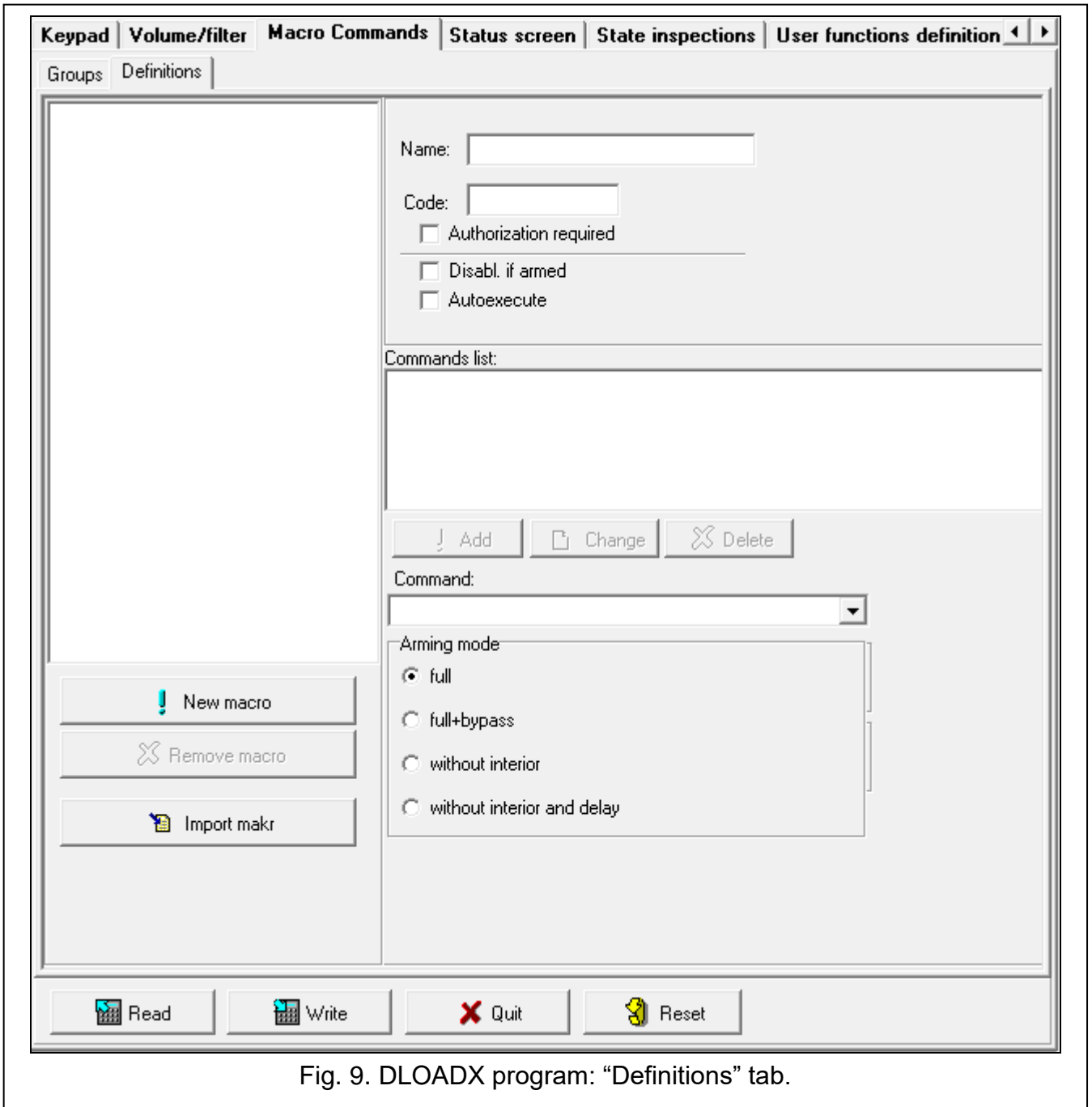



Fig. 9. DLOADX program: “Definitions” tab.

Command – function that you can assign to the macro command. Click  to drop down the list of available functions, then click on the function that you want to assign to the macro command.

 *The KNX telegram and KNX telegram (v2) functions allow you to control the KNX system if the INT-KNX or the INT-KNX-2 module is connected to the control panel.*

List – fields in this table represent the system elements (partitions / zones / outputs) that can be controlled by the function. The numbers of the fields in the table correspond to the numbers of the elements in the system. The color of the field indicates:

- orange – function controls this system element,
- white – function does not control this system element.

Double-click the field to change its color.

Depending on the selected function:

Arming – select the partitions to be armed and define the arming mode (successive clicks on the field). The digit inside the field indicates:

- 0 – fully armed,
- 1 – fully armed + bypasses,
- 2 – armed without interior,
- 3 – armed without interior and without entry delay.

Disarming – select the partitions to be disarmed.

Alarm clearing – select the partitions in which alarm is to be cleared.

Bypass zones – select the zones which are to be inhibited.

Unbypass zones – select the zones which are to be unbypassed.

Outputs ON – select the outputs to be turned on.

Outputs OFF – select the outputs to be turned off.

Change outputs state – select the outputs whose state is to be changed.



The partitions must be controlled by user code.

The Bypass disabled option must not be enabled in the zones.

The outputs must be the 24: MONO switch, 25: BI switch, 105: Shutter up, 106: Shutter down or Remote switch type (they do not need to be assigned to any group of outputs).

KNX telegram – if you select this function, configure the following parameters of the KNX telegram:

Module INT-KNX – INT-KNX module that is to send the telegram.

Group address – group address that will be inserted in the telegram.

Type – telegram type.

Value – value that will be inserted in the telegram (parameter available for some telegram types).

Priority – telegram priority (if two elements of the bus start transmitting simultaneously, the telegram with higher priority will be sent first).

KNX telegram (v2) – if you select this function, configure the following parameters related to setting the value of the KNX communication object:

Module INT-KNX – INT-KNX-2 module in which the value is to be set.

Macro Command – name of the *Virtual (macro)* type object, defined in the INT-KNX-2 module.

Data type – size and meaning of the communication object data defined in INT-KNX-2 module for selected object.

Value – value to be set (if the type of data provides for sending a sequence of characters, you can enter up to 13 characters).

Preparing a macro command

1. Click on the "Read" button to read the macro command settings from the keypad.
2. Click on the "Definitions" tab.
3. Click on the "New macro" button. A new macro command will appear in the list.
4. Enter a name for the new macro command.

5. If the user is to run the macro command without entering the code, enter the code. You can create an additional user whose code will be used for the purpose of macro commands. The user must have a suitable authority level in order to be able to run the functions that you want to assign to the macro command.
6. If the users are to use their own code to run macro commands, enable the *Authorization required* option.
7. If the macro command is to be unavailable, when any of the partitions operated by the keypad is armed, enable the *Disabl. if armed* option.
8. If the macro command is to be run instantly on touching —, enable the *Autoexecute* option (assign to the group only this one macro command).
9. Click  in the “Command” field and select from the list the function that will be executed by the new macro command.
10. Configure the command settings (e.g. select the partitions to be disarmed).
11. Click on the “Add” button. A new command will appear in the list of commands assigned to the macro command. After clicking on the command, you can change its settings (after making changes, click on the “Change” button).
12. Repeat the steps 9-11 if you want the macro command to execute more functions.
13. Click on the “Groups” tab.
14. Click on the group to which you want to assign the macro command.
15. Enter the group name.
16. Click on the “Add macro” button. The list of available macro commands will be displayed.
17. Click on the macro command to add it to the group. The macro command will be displayed on the tree under the group.
18. Click on the “Write” button to write the macro command settings to the keypad.

Buttons

Read – click to read data from the keypad.

Write – click to write data to the keypad.

Quit – click to cancel the reading / writing of data.

Reset – click to restore the factory default settings of the keypad (this command applies to the settings stored in the keypad).

Status screen (Screensaver)

The screensaver is displayed after 60 seconds of keypad inactivity (when no menu is displayed) or on touching *≡.



The screensaver settings are stored in the keypad. Therefore, before you make any changes, click on the “Read” button, and after you make the changes, click on the “Write” button (Fig. 10). The screensaver settings are not read / written after clicking

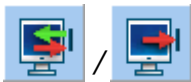

in the main menu.

[List of displayed items] – list of items displayed in the screensaver mode is presented in this field.



– click to move the selected item up.



– click to move the selected item down.

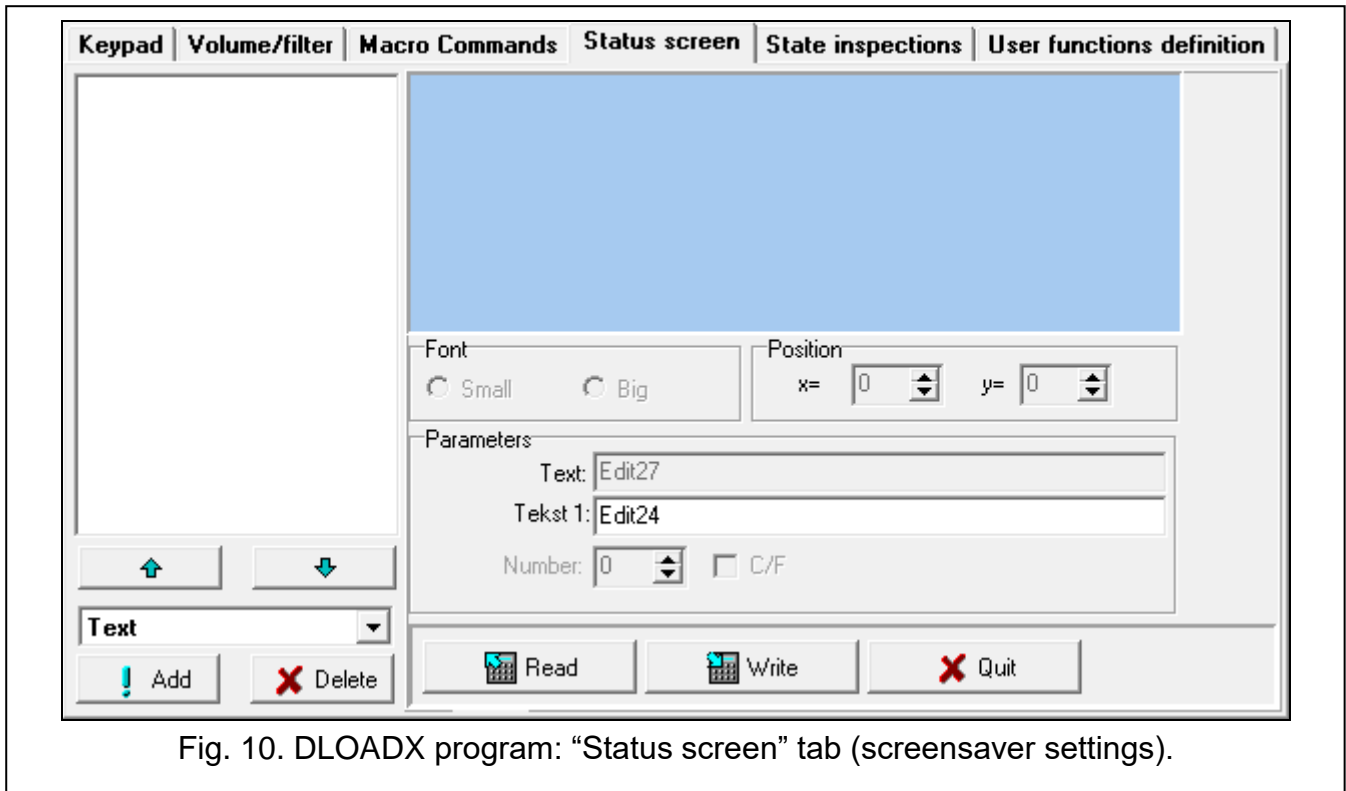



Fig. 10. DLOADX program: "Status screen" tab (screensaver settings).

[Item] – in this field you can select the item you want to place on the display. Click  to drop down the list of available items, then click the item that you want to select. Click "Add" to add the selected item to the display.

Text – text of your choice.

Partition state – symbol that indicates the partition state. After you add the item, select the partition number.

Zone state – symbol that indicates the zone state. After you add the item, select the zone number.

Output state – symbol that indicates the output state. After you add the item, select the output number.

Temperature – information on temperature from an ABAX / ABAX 2 wireless device. After you add the item:

- select the number of the zone to which the ABAX / ABAX 2 device is assigned,
- decide if the temperature is to be displayed in degrees Celsius or Fahrenheit.

Day (digit) – number of the day of the month made up of one or two digits.

Day (always two digits) – number of the day of the month made up of two digits (numbers 1-9 will be preceded by 0, e.g. 01).

Day of week – name of the day of the week abbreviated to three letters.

Month (digit) – number of the month made up of one or two digits.

Month (always two digits) – number of the month made up of two digits (numbers 1-9 will be preceded by 0, e.g. 01).

Month (name) – name of the month abbreviated to three letters.

Year (2 digits) – last two digits of the year.

Year (4 digits) – year in full.

Hour – number of hours made up of one or two digits.

Hour (always two digits) – number of hours made up of two digits (numbers 1-9 will be preceded by 0, e.g. 01).

Minutes – number of minutes made up of one or two digits.

Minutes (always two digits) – number of minutes made up of two digits (numbers 1-9 will be preceded by 0, e.g. 01).

Seconds – number of seconds made up of one or two digits.

Seconds (always two digits) – number of seconds made up of two digits (numbers 1-9 will be preceded by 0, e.g. 01).

colon (blinking) – blinking colon to separate items.

Keypad number – name given to the keypad.

Zone state (text) – message indicating the zone state. After you add the item, select the zone number and enter the message to be displayed.

Output state (text) – message indicating the output state. After you add the item, select the output number and enter the message to be displayed.

Analog value – information on the power consumption of the appliance connected to the ASW-200 smart plug. After you add the item, select the number of the output to which the ASW-200 smart plug is assigned.

Add – click to add the item selected from the list above (*[Item]*).

Delete – click to delete the selected item.

[Display preview] – display preview shows how the items are arranged. Use the “drag and drop” method to move the items around the display.

Font – size of the item on the display. Two sizes are available: *Small* or *Big*.

Position – position of the item on the display as specified by the coordinates: x (distance from the left edge of the display) and y (distance from the upper edge of the display).

Text – text to be displayed. The field is available for the *Text* item.

Normal state – message informing the user that the zone is in the normal state. The field is available for the *Zone state (text)* item.

Violation – message informing the user that the zone is violated. The field is available for the *Zone state (text)* item.

Active – message informing the user that the output is active. The field is available for the *Output state (text)* item.

Off – message informing the user that the output is inactive. The field is available for the *Output state (text)* item.

Number – number of the partition (for the *Partition state* item) / zone (for the *Zone state* and *Zone state (text)* item) / output (for the *Output state*, *Output state (text)* and *Analog value* item).

Zone – number of the zone to which the ABAX / ABAX 2 device providing temperature information is assigned. The field is available for the *Temperature* item.

C/F – if the option is enabled, the temperature is displayed in degrees Fahrenheit. If the option is disabled, the temperature is displayed in degrees Celsius. The field is available for the *Temperature* item.

Buttons

Read – click to read data from the keypad.



Write – click to write data to the keypad.

Quit – click to cancel the reading / writing of data.

EOL resistance value

The tab is available if the keypad is connected to the INTEGRA control panel.



The EOL resistor settings are stored in the keypad. Therefore, before you make any changes, click on the “Read” button, and after you make the changes, click on the “Write” button (Fig. 11). The settings stored in the keypad are not read / written after clicking  /  in the main menu.

In the INTEGRA Plus control panel, you can define the EOL resistance value for the mainboard zones. The same resistors must be used for all zones for which the EOL resistance value is programmable (including the keypad zones).

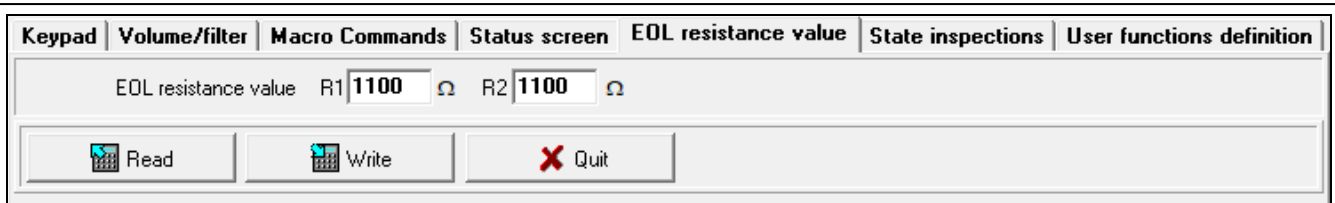

Fig. 11. DLOADX program: “EOL resistance value” tab (default settings).

R1 – value of the R1 resistor (see Fig. 12). You can enter values from 500 Ω to 15 kΩ. By default: 1.1 kΩ.

R2 – value of the R2 resistor (see Fig. 12). You can enter values from 500 Ω to 15 kΩ or 0. If you enter 0, the value of resistors used in the Double EOL configuration must be equal to half the value programmed for the R1 resistor (the value of one resistor must not be less than 500 Ω). By default: 1.1 kΩ.



The resistor value for Single EOL configuration is the sum of R1 and R2 resistors.

Buttons

Read – click to read data from the keypad.

Write – click to write data to the keypad.

Quit – click to cancel the reading / writing of data.

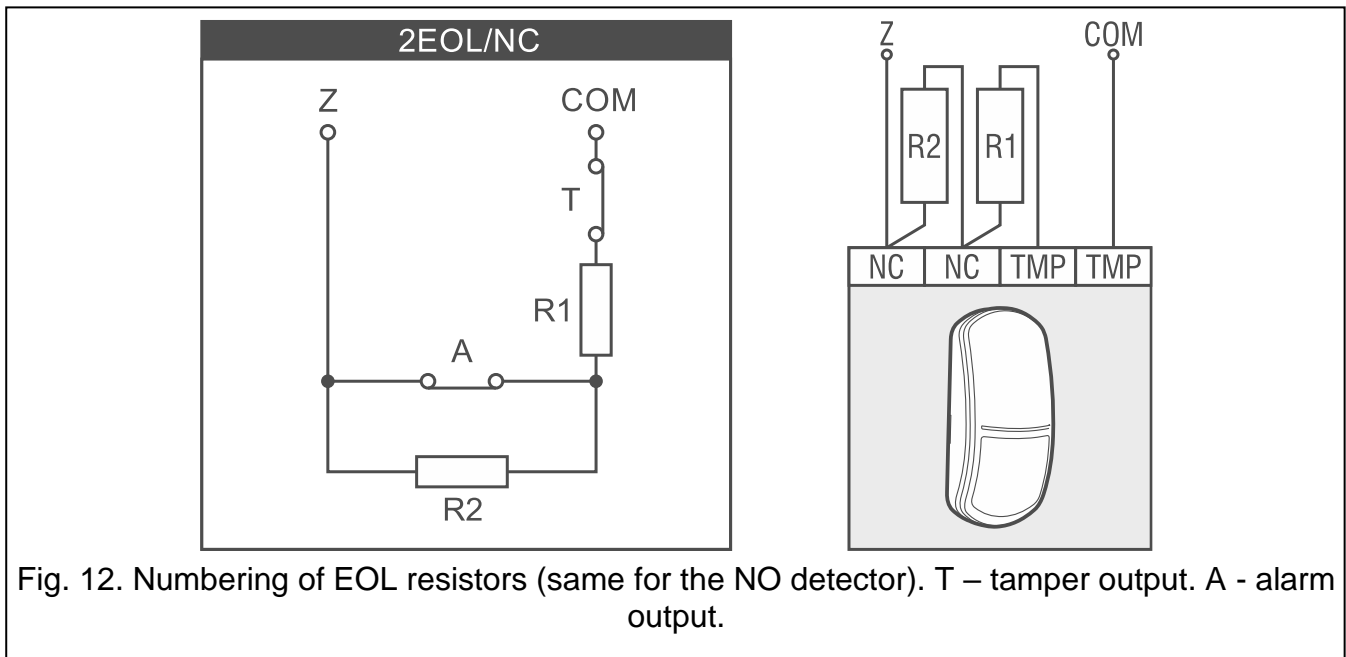

Fig. 12. Numbering of EOL resistors (same for the NO detector). T – tamper output. A - alarm output.

State inspections

Key hold-down

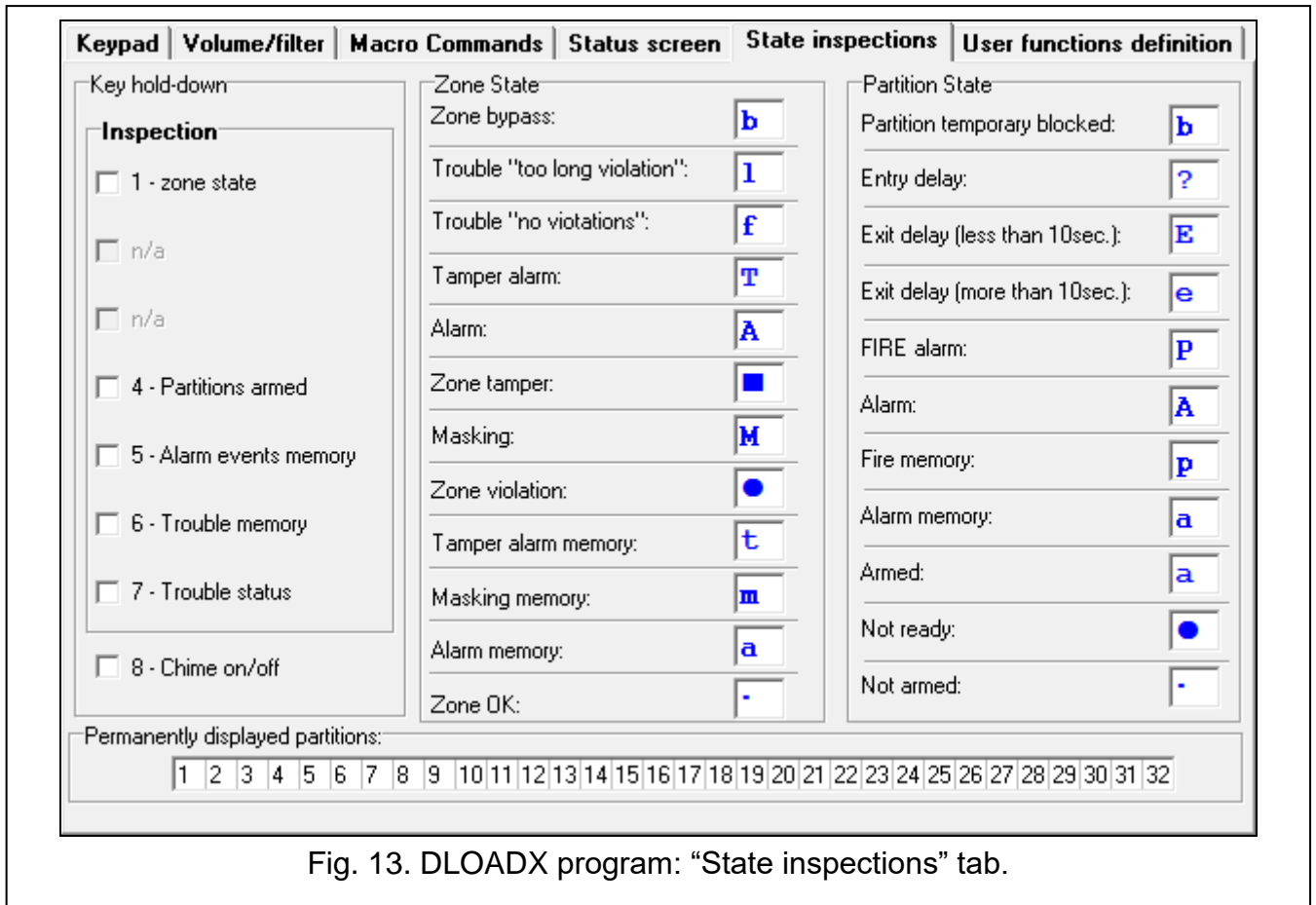

Fig. 13. DLOADX program: “State inspections” tab.

Some functions can be run by the users without having to enter the code.

- 1 – zone state** [Zones] – if this option is enabled, the user can touch and hold 1_{! ? @} for 3 seconds to check the state of zones.
- 4 – Partitions armed** [Partitions] – if this option is enabled, the user can touch and hold 4_{GHI} for 3 seconds to check the state of partitions.
- 5 – Alarm events memory** [Alarms log] – if this option is enabled, the user can touch and hold 5_{JKL} for 3 seconds to view the alarms log (based on the event log).
- 6 – Trouble memory** [Troubles log] – if this option is enabled, the user can touch and hold 6_{MNO} for 3 seconds to view the troubles log (based on the event log).
- 7 – Trouble status** [Troubles] – if this option is enabled, the user can touch and hold 7_{PQRS} for 3 seconds to view the troubles.
- 8 – Chime on/off** [Chime changing] – if this option is enabled, the user can touch and hold 8_{TUV} for 3 seconds to turn on / off the CHIME feature in the keypad.

Zone State [Zone characters]

You can define the symbols that will illustrate the state of zones on the display.

Partition State [Part.characters]

You can define the symbols that will illustrate the state of partitions on the display.

Permanently displayed partitions [State part.]

You can select the partitions whose state will be permanently presented in the lower line of the display. Up to 16 partitions can be selected. The partitions are displayed successively: for example, if you select the partitions 3, 6 and 7, their state will be displayed in the first, second and third position of the display.



If the Show keypad name option is enabled, the partition state is not displayed.

User functions definition

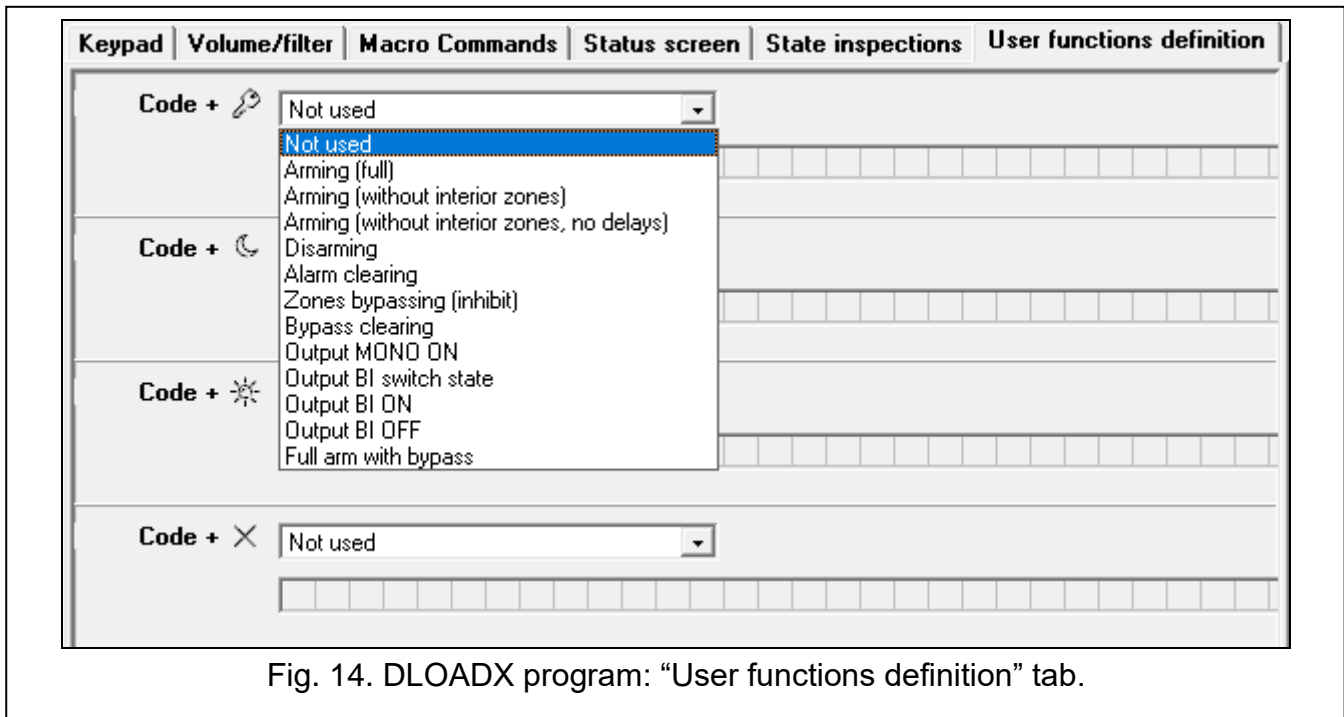

Fig. 14. DLOADX program: "User functions definition" tab.

Code + [Code↑ function] – function started after entering the code and touching .

Code + [Code← function] – function started after entering the code and touching .

Code + [Code→ function] – function started after entering the code and touching .

Code + [Code↓ function] – function started after entering the code and touching .

Proximity cards

Card function

Card read [Card close] – the function started after presenting the card.

Card hold-down [Card close long] – the function started after holding the card.

Door [Door to open] – if a door is to be open after presenting or holding the card, select the door supervised by the access control module or the *101. Card read – expander* type output.

Fig. 15. DLOADX program: “Proximity cards” tab.

Wrong card

Signal on wrong card [Unkn.card sig.] – if this option is enabled, when an unknown card is read, it is signaled by two long beeps.

Event after 3 readings [Ev.3 unk.cards] – if this option is enabled, when an unknown card is read three times, the event will be saved.

Alarm after 3 readings [Al.3 unk.cards] – if this option is enabled, when an unknown card is read three times, alarm will be generated. The option is available if the *Event after 3 readings* option is enabled.

Code+card

Select the user authentication method:

Code OR card – the user can use code or card.

Code AND card – the user must use both code and card.

Follow output – the authentication method depends on the status of selected output (output is active – code and card; output is inactive – code or card).



In case of the authentication using code and card, the executed function depends on the second identifier.

The outputs 255 and 256 cannot be used for controlling the authentication method.

4.2 Keypad in the PERFECTA 64 M system

You can configure all the keypad settings from the computer with the PERFECTA SOFT program installed. Not all settings can be configured using the keypad. Names of parameters and options from the PERFECTA SOFT program are used in this manual. When a parameter or option is described, you will find one of the following information in square brackets:

- name of the function used to configure a parameter or option in the keypad,
- name of a parameter or option from the keypad.

4.2.1 Programming in the PERFECTA SOFT program

Required version of the PERFECTA SOFT program: 2.00 (or newer).

1. Click on the “Hardware” tab.
2. Click on the keypad whose settings you want to configure.
3. Configure the keypad settings.
4. Click to save changes to the control panel.

4.2.2 Programming from the keypad

1. Enter the **service code** (by default: 12345) and touch *≡. The user menu will be displayed.
2. Find the *Service mode* function (use the swipe up gesture) and touch #✓. The service menu will be displayed.
3. Touch 2_{ABC} #✓ to enter the *2.Expanders* submenu.
4. Use the function available in the submenu to configure the keypad settings. For instructions on how to edit data, please refer to the control panel programming manual (instead of arrow keys, use the swipe gesture).

4.2.3 Keypad settings

Name [28.Names] – individual name of the keypad (up to 16 characters).

Alarm in part. [22.Partitions] – the partition in which alarm will be generated in the event of keypad tamper (opening of enclosure or loss of communication).

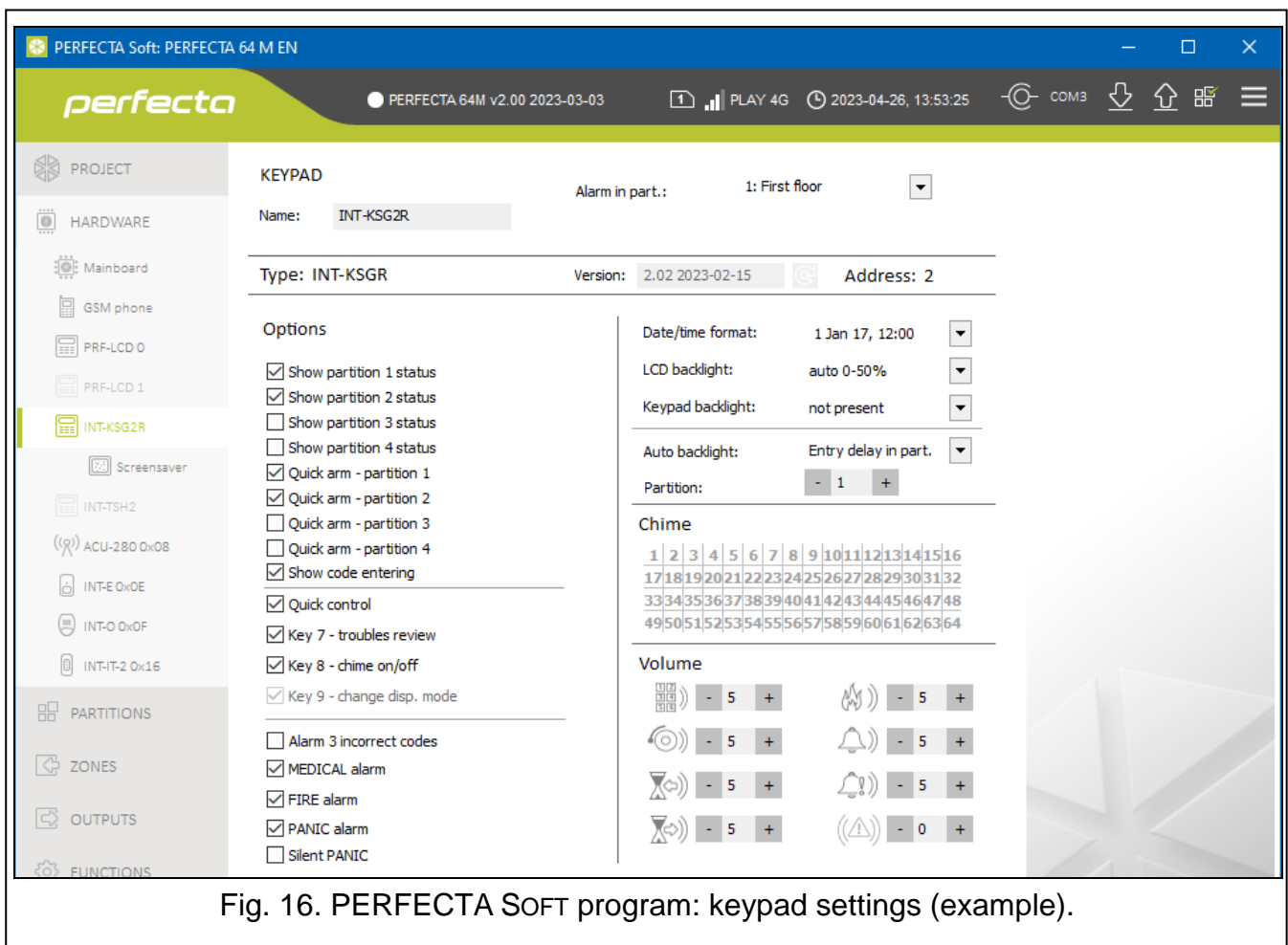

Fig. 16. PERFECTA SOFT program: keypad settings (example).

Options

Show partition 1 status [Show part.1] – if this option is enabled, the keypad indicates the status of partition 1 (display / LEDs / audible signal).

Show partition 2 status [Show part.2] – if this option is enabled, the keypad indicates the status of partition 2 (display / LEDs / audible signal).

Show partition 3 status [Show part.3] – if this option is enabled, the keypad indicates the status of partition 3 (display / LEDs / audible signal).

Show partition 4 status [Show part.4] – if this option is enabled, the keypad indicates the status of partition 4 (display / LEDs / audible signal).

- Quick arm - partition 1** [Quickarm part.1] – if this option is enabled, the user can arm partition 1 from the keypad without using code.
- Quick arm - partition 2** [Quickarm part.2] – if this option is enabled, the user can arm partition 2 from the keypad without using code.
- Quick arm - partition 3** [Quickarm part.3] – if this option is enabled, the user can arm partition 3 from the keypad without using code.
- Quick arm - partition 4** [Quickarm part.4] – if this option is enabled, the user can arm partition 4 from the keypad without using code.
- Show code entering** [Show code enter.] – if this option is enabled, entering the code is presented on the keypad display by asterisks.
- Quick control** [Quick control] – if this option is enabled, the users can control the outputs by using the number keys. The 15. *Controlled* outputs must be assigned to the keys (see: PERFECTA 64 M control panel *Programming* manual).
- Key 7 – troubles review** [Troubles review] – if this option is enabled, the user can touch and hold 7_{RS}^{PQ} for 3 seconds to view the troubles.
- Key 8 – chime on/off** [Chime on/off] – if this option is enabled, the user can touch and hold 8_{TUV} for 3 seconds to turn on / off the CHIME feature in the keypad.
- Alarm 3 incorrect codes** [3 wrng codes al.] – if this option is enabled, entering incorrect code three times will generate the alarm.
- MEDICAL alarm** [Medical alarm] – if this option is enabled, the user can generate the medical alarm by touching and holding Ⓜ for 3 seconds.
- FIRE alarm** [Fire alarm] – if this option is enabled, the user can generate the fire alarm by touching and holding Ⓧ for 3 seconds.
- PANIC alarm** [Panic alarm] – if this option is enabled, the user can generate the panic alarm by touching and holding Ⓨ for 3 seconds.
- Silent PANIC** [Silent panic] – if this option is enabled, the panic alarm generated from the keypad will be a silent one, i.e. the keypad will not indicate it, there will be no audible signal, but the alarm will be reported to the monitoring station. The silent panic alarm is useful when the control panel is sending events to the monitoring station, but unauthorized persons should not be aware of the alarm being generated. The option is available, if the *PANIC alarm* option is enabled.

Display and keys

- Date/time format** [210.ClockFormat] – mode of presentation of time and date on the display.
- LCD backlight** [26.LCDbacklight] – the way the display backlight works.
- Keypad backlight** [27.KEYbacklight] – the way the keys backlight works.
- Auto backlight** [29.Autolight] – if the display or keys backlight is turned on automatically, you can define whether the backlight will be additionally turned on by an event and select the event:
- NOT PRESENT** – the backlight will be turned on by touching any key.
 - Zone violation** – the backlight will be additionally turned on if a zone is violated (select the zone).
 - Entry delay in part.** – the backlight will be additionally turned on if entry delay countdown starts in a partition (select the partition).











If the entry delay in a partition is to turn on the backlight, the keypad must indicate the partition status (see the Show partition status options).

Chime

The keypad can audibly signal violation of selected zones.

Volume

-  [251.Keys] – volume of the beeps generated during keypad operation (key touching, confirmation of performed operation, etc.).
-  [252.Chime] – volume of the beeps generated after zone violation (CHIME).
-  [253.Entry delay] – volume of the entry delay signaling.
-  [254.Exit delay] – volume of the exit delay signaling.
-  [255.Fire alarm] – volume of the fire alarm signaling.
-  [256.Burg.alarm] – volume of the burglary, panic and medical alarm signaling.
-  [257.Warn.alarm] – volume of the warning alarm signaling.
-  [258.New trouble] – volume of the trouble signaling.

Screensaver

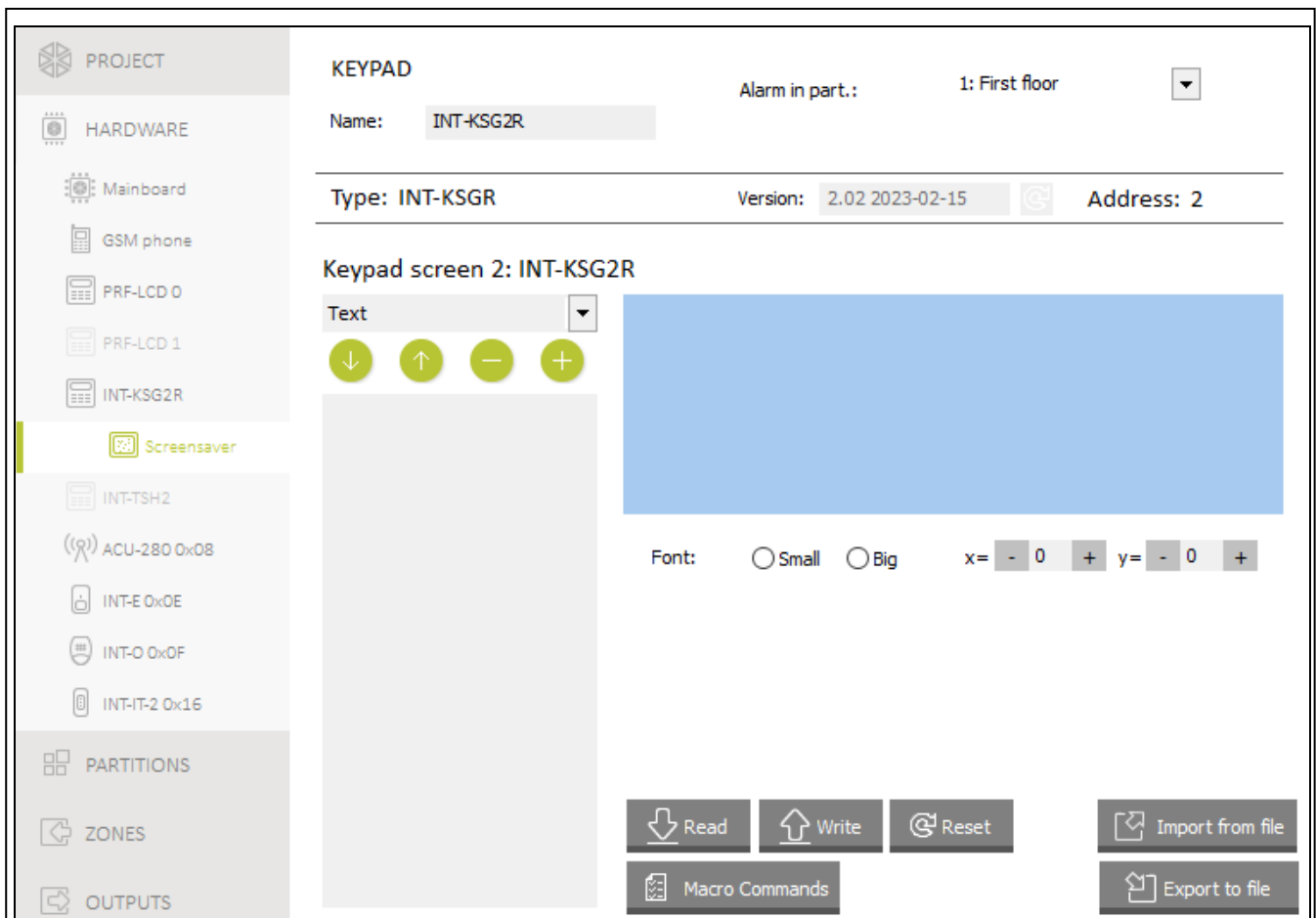





Fig. 17. PERFECTA SOFT program: screensaver settings.

The screensaver is displayed after 60 seconds of keypad inactivity (when no menu is displayed) or on touching * ≡.

i The screensaver settings are stored in the keypad. Therefore, before you make any changes, click on the “Read” button, and after you make the changes, click on the

“Write” button (Fig. 17). The screensaver settings are not read / written after clicking  /  on the menu bar.

[Item] – in this field you can select the item you want to place on the display. Click  to drop down the list of available items, then click the item that you want to select. Click  to add the selected item to the display.

Text – text of your choice.

Partition state – symbol that indicates the partition state. After you add the item, select the partition (click  to drop down the list of partitions, then click the partition whose state is to be shown on the display).

Zone state – symbol that indicates the zone state. After you add the item, select the zone (click  to drop down the list of zones, then click the zone whose state is to be shown on the display).

Output state – symbol that indicates the output state. After you add the item, select the output (click  to drop down the list of outputs, then click the output whose state is to be shown on the display).

Temperature – information on temperature from an ABAX 2 wireless device. After you add the item:

- select the zone to which the ABAX 2 device is assigned (click  to drop down the list of zones, then click the zone to which the ABAX 2 device is assigned),
- decide if the temperature is to be displayed in degrees Celsius or Fahrenheit.

Day (digit) – number of the day of the month made up of one or two digits.

Day (2 digits) – number of the day of the month made up of two digits (numbers 1-9 will be preceded by 0, e.g. 01).

Day of week – name of the day of the week abbreviated to three letters.

Month (digit) – number of the month made up of one or two digits.

Month (2 digits) – number of the month made up of two digits (numbers 1-9 will be preceded by 0, e.g. 01).

Month (name) – name of the month abbreviated to three letters.

Year (2 digits) – last two digits of the year.

Year (4 digits) – year in full.

Hour – number of hours made up of one or two digits.

Hour (2 digits) – number of hours made up of two digits (numbers 1-9 will be preceded by 0, e.g. 01).

Minutes – number of minutes made up of one or two digits.

Minutes (2 digits) – number of minutes made up of two digits (numbers 1-9 will be preceded by 0, e.g. 01).

Seconds – number of seconds made up of one or two digits.

Seconds (2 digits) – number of seconds made up of two digits (numbers 1-9 will be preceded by 0, e.g. 01).





colon (blinking) – blinking colon to separate items.

Keypad number – name given to the keypad.

Zone state (text) – message indicating the zone state. After you add the item, select the zone number and enter the message to be displayed.

Output state (text) – message indicating the output state. After you add the item, select the output number and enter the message to be displayed.

Power measuring – information on the power consumption of the appliance connected to the ASW-200 smart plug. After you add the item, select the output to which the ASW-200 plug is assigned (click  to drop down the list of outputs, then click the output to which the ASW-200 plug is assigned).

-  – click to move down the item selected in the field below (*[List of displayed items]*).
-  – click to move up the item selected in the field below (*[List of displayed items]*).
-  – click to delete the item selected in the field below (*[List of displayed items]*).
-  – click to add the item selected from the list above (*[Item]*). The item will be displayed in the field below (*[List of displayed items]*).

[List of displayed items] – list of items displayed in the screensaver mode is presented in this field.

[Display preview] – display preview shows how the items are arranged. Use the “drag and drop” method to move the items around the display.

Font – size of the item on the display. Two sizes are available: *Small* or *Big*.

x – distance between the item and the left edge of the display.

y – distance between the item and the upper edge of the display.

Read – click to read the screensaver and macro command settings from the controller.

Write – click to write the screensaver and macro command settings to the controller.

Reset – click to restore the factory default settings of the screensaver and macro commands.

Macro Commands – click to open the window with macro command settings.



Import from file – click to import the screensaver settings from a file.

Export to file – click to export the screensaver settings to a file.

Macro command settings

The macro command is a sequence of actions to be performed by the control panel. The macro commands help the user to operate the alarm system. Instead of performing several operations (e.g. in order to arm the selected partitions) the user can run a macro command, and the control panel will execute the functions assigned to it.





The macro command settings are stored in the keypad. Therefore, before you open the window with macro command settings, click on the “Read” button, and after you make the changes and close the window, click on the “Write” button (Fig. 17). The macro command settings are not read / written after clicking  /  on the menu bar.

Macro groups

The macro commands which are to be available to the keypad users must be assigned to one of the four groups. You can assign up to 16 macro commands to the group.

Group name – name of the macro command group (up to 8 characters). It is presented on the bottom of the display, above the  key.

List of macro commands – macro commands assigned to the group.

-  – click to add the macro command to the group. The list of available macro commands will be displayed. Click on the macro commands you want to add to the group.
-  – click to delete the selected macro command from the group.
-  – click to move the selected macro command up.

 – click to move the selected macro command down.

Macro Commands

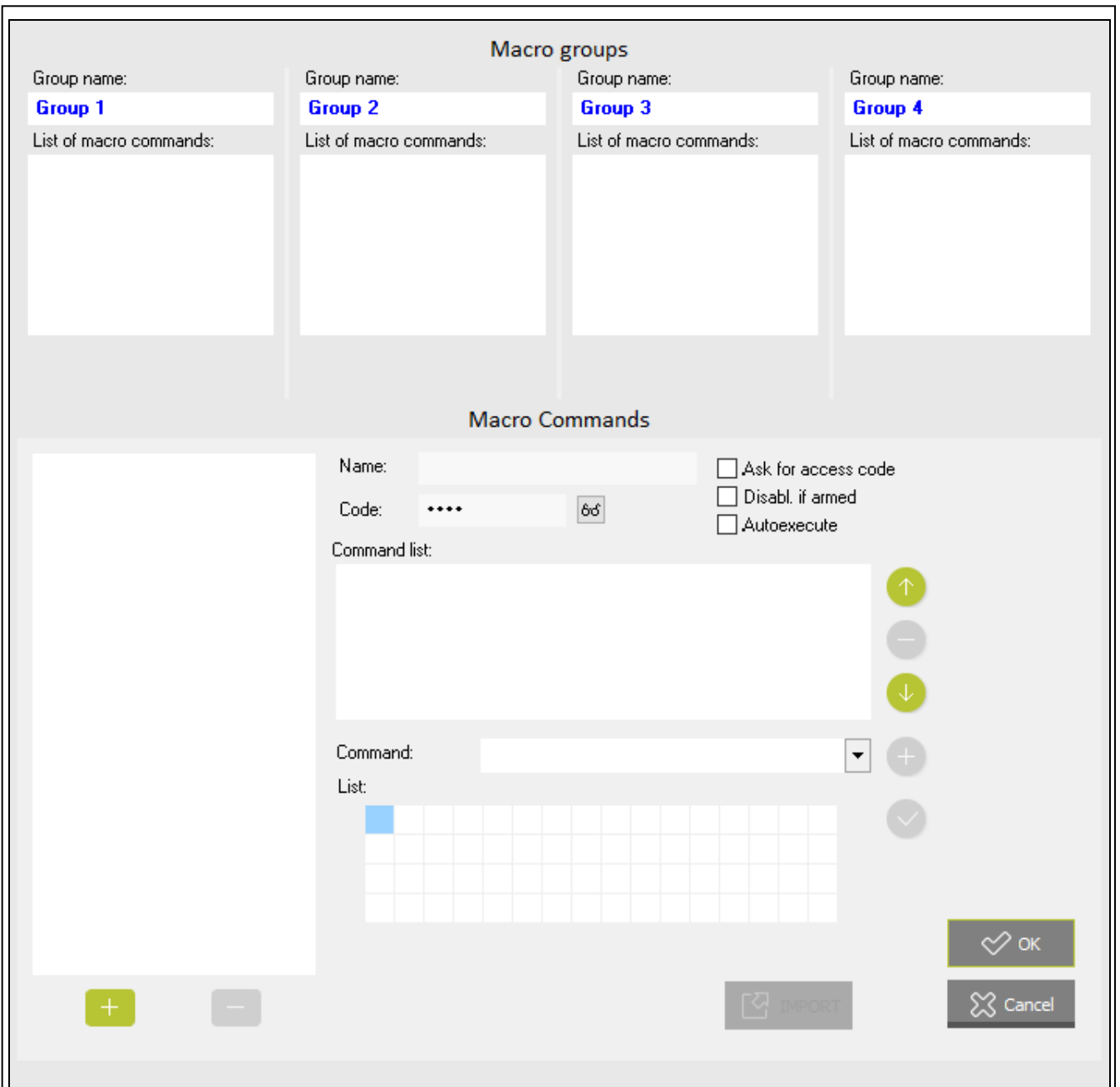





Fig. 18. PERFECTA SOFT program: macro command settings.

 – click to create a new macro command.

 – click to delete the selected macro command.

Name – individual name of the macro command (up to 16 characters).

Code – code sent to the control panel when commands contained in the macro command are executed. For execution of such commands to be possible, the code must have a suitable authority level.

 *If, when executing a macro command, it turns out that the code is invalid (e.g. it has been changed), the user will be asked to enter the correct code. It will be automatically saved to the keypad memory (replacing the invalid one).*

Authorization required – if this option is enabled, the macro command is executed only after the user enters the code (the code entered in the “Code” field is not used).

Disabl. if armed – if this option is enabled, the macro command is not available when any of the partitions operated by the keypad is armed.

Autoexecute – if this option is enabled and there is just one macro command in the group, the macro command will be executed instantly on touching the **—** key.

Commands list – commands assigned to the currently highlighted macro command.

 – click to move the selected command up.

 – click to remove the selected command from the macro.

 – click to move the selected command down.

Command – function that you can assign to the macro command. Click  to drop down the list of available functions, then click on the function that you want to assign to the macro command.

 – click to add to the list a new command selected in the “Command” field.

 – click to save the changes to the command settings that were made after adding the command to the list (otherwise, the changes will not be saved).

Partition 1 / Partition 2 – function run in the partition if the *Arming* command is selected:

none – no function,

Full arm – arming in full mode,

Night arm – arming in night mode,

Day arm – arming in day mode.

no exit delay – if this option is enabled, the partition will be armed instantly (the exit delay countdown will not run). The option is available for the *Arming* command.

Partitions – the numbers of the fields in the table correspond to the numbers of the partitions. Double-click the field to change its color (orange – function controls the partition; white – function does not control the partition). The table is available for the *Disarming* and *Alarm clearing* commands.

Zones – the numbers of the fields in the table correspond to the numbers of the zones. Double-click the field to change its color (orange – function controls the zone; white – function does not control the zone). The table is available for the *Bypass zones* and *Unbypass zones* commands.

Outputs – the numbers of the fields in the table correspond to the numbers of the outputs. Double-click the field to change its color (orange – function controls the output; white – function does not control the output). The table is available for the *Outputs ON*, *Outputs OFF* and *Change outputs state* commands.

Buttons







Import – click to import macro commands settings from another keypad.

OK – click to confirm the changes and close the window.

Cancel – click to close the window without saving the changes.

Preparing a macro command

1. Click on the “Read” button in the “Screensaver” tab to read the macro command settings from the keypad.
2. Click on the “Macro Commands” button. The window with macro command settings will be displayed.

3. Click . A new macro command will appear in the list.
4. Enter a name for the new macro command.
5. If the user is to run the macro command without entering the code, enter the code. You can create an additional user whose code will be used for the purpose of macro commands. The user must have a suitable authority level in order to be able to run the functions that you want to assign to the macro command.
6. If the users are to use their own code to run macro commands, enable the *Authorization required* option.
7. If the macro command is to be unavailable, when any of the partitions operated by the keypad is armed, enable the *Disabl. if armed* option.
8. If the macro command is to be run instantly on touching , enable the *Autoexecute* option (assign to the group only this one macro command).
9. Click  in the “Command” field and select from the list the function that will be executed by the new macro command.
10. Configure the command settings (e.g. select the partitions to be disarmed).
11. Click  next to the “Command” field. A new command will appear in the list of commands assigned to the macro command. After clicking on the command, you can change its settings (after making changes, click ).
12. Repeat the steps 9-11 if you want the macro command to execute more functions.
13. Enter the name of the group to which you want to assign the macro command.
14. Click  below the “List of macro commands” field. The list of available macro commands will be displayed.
15. Click on the macro command to add it to the group. The macro command will be displayed on the list.
16. Click on the “OK” button to confirm the changes and close the window.
17. Click on the “Write” button to write the macro command settings to the keypad.

5. Updating the keypad firmware

1. Connect the keypad to the ACCO-USB converter using the RS-485 bus (see: the ACCO-USB converter manual).
2. Connect the ACCO-USB converter to the computer USB port.
3. Download the keypad firmware update program from the support.satel.pl website.
4. Start the downloaded program.
5. Click on the  button.
6. In the window that will open, indicate the COM port to which the ACCO-USB converter is connected, and then click “OK”.
7. When a command is displayed prompting you to power the keypad off and on, restart the device.
8. The program will read information on the firmware version from the keypad.
9. When a window prompt is displayed asking you whether to continue the firmware update, click on the “Yes” button.
10. The keypad firmware will be updated.



Instead of the ACCO-USB converter, you can use another USB-RS-484 converter.

6. Specifications

Supply voltage	12 VDC \pm 15%
Standby current consumption	135 mA
Maximum current consumption	155 mA
Reader transmit frequency	13.553...13.567 MHz
Read range of MC-DF3-2 encrypted card	up to 55 mm
Security grade according to EN50131	Grade 3
Environmental class according to EN 50130-5	II
Working temperature range	-10°C...+55°C
Maximum humidity	93 \pm 3%
Enclosure dimensions (width x height x thickness)	132 x 129 x 17 mm
Weight.....	224 g

7. Manual update history

Manual version	Introduced changes
04/24	<ul style="list-style-type: none"> Information on the built-in MIFARE proximity card reader has been updated. Information on the required DLOADX program version has been updated (p. 10). Description of the encryption settings for the MIFARE card in the INTEGRA system has been added (p. 11). Description of the proximity card settings in the INTEGRA system has been added (p. 24). Specifications have been supplemented (p. 34).