

Access control module ACCO

ACCO-KP2

Firmware version 1.01

EN

CE



QUICK INSTALLATION GUIDE

acco-kp2_sii_en 10/24

Satel ®

SATEL sp. z o.o. • ul. Budowlanych 66 • 80-298 Gdańsk • POLAND
tel. +48 58 320 94 00
www.satel.pl

IMPORTANT

Full manual is available at www.satel.pl. Scan the QR code to go to our website and download the manual.



The device should be installed by qualified personnel.

Prior to installation, please read carefully this manual.

Changes, modifications or repairs not authorized by the manufacturer shall void your rights under the warranty.

In this device we used:

- Keil RTX5 – under Apache 2.0 license (<https://www2.keil.com/mdk5/cmsis/rtx>)
- 1wIP – under BSD license (<https://savannah.nongnu.org/projects/1wip>).

SATEL aims to continually improve the quality of its products, which may result in changes in their technical specifications and software. Current information about the changes being introduced is available on our website.

Please visit us at:
<https://support.satel.pl>

The declaration of conformity may be consulted at www.satel.pl/ce

Signs in this manual



Caution – information on the safety of users, devices, etc.



Note – suggestion or additional information.

CONTENTS

| | |
|--|---|
| 1. Electronics board | 2 |
| Description of terminals..... | 2 |
| 1.1 Address setting | 3 |
| 2. Devices interfacing with the module | 4 |
| 2.1 User identification devices (terminals)..... | 4 |
| 3. Access control module installation | 5 |
| 3.1 Installing and connecting the terminals | 5 |
| 3.1.1 Connecting the ACCO-KLCDR keypad..... | 5 |
| 3.1.2 Connecting the ACCO-SCR keypad | 6 |
| 3.1.3 Connecting the CR-MF5 and SO-MF5 keypads..... | 6 |
| ACCO-SCR interface | 6 |
| RS-485 bus (OSDP)..... | 6 |
| 3.1.4 Connecting the CZ-EMM, CZ-EMM2, CZ-EMM3 and CZ-EMM4 readers..... | 7 |
| 3.1.5 Connecting the CR-MF3 and SO-MF3 readers | 7 |
| EM-Marine interface..... | 7 |
| Wiegand interface | 8 |
| RS-485 bus (OSDP)..... | 8 |
| 3.1.6 Connecting a third-party reader..... | 8 |
| 3.1.7 Connecting the DALLAS iButton reader..... | 9 |
| 3.2 Connecting activators and door sensors | 9 |
| 3.3 Connecting the power supply and starting the module..... | 9 |

This manual contains basic information on how to install the ACCO-KP2 module. For further information, please refer to the full installer manual available at www.satel.pl.

1. Electronics board

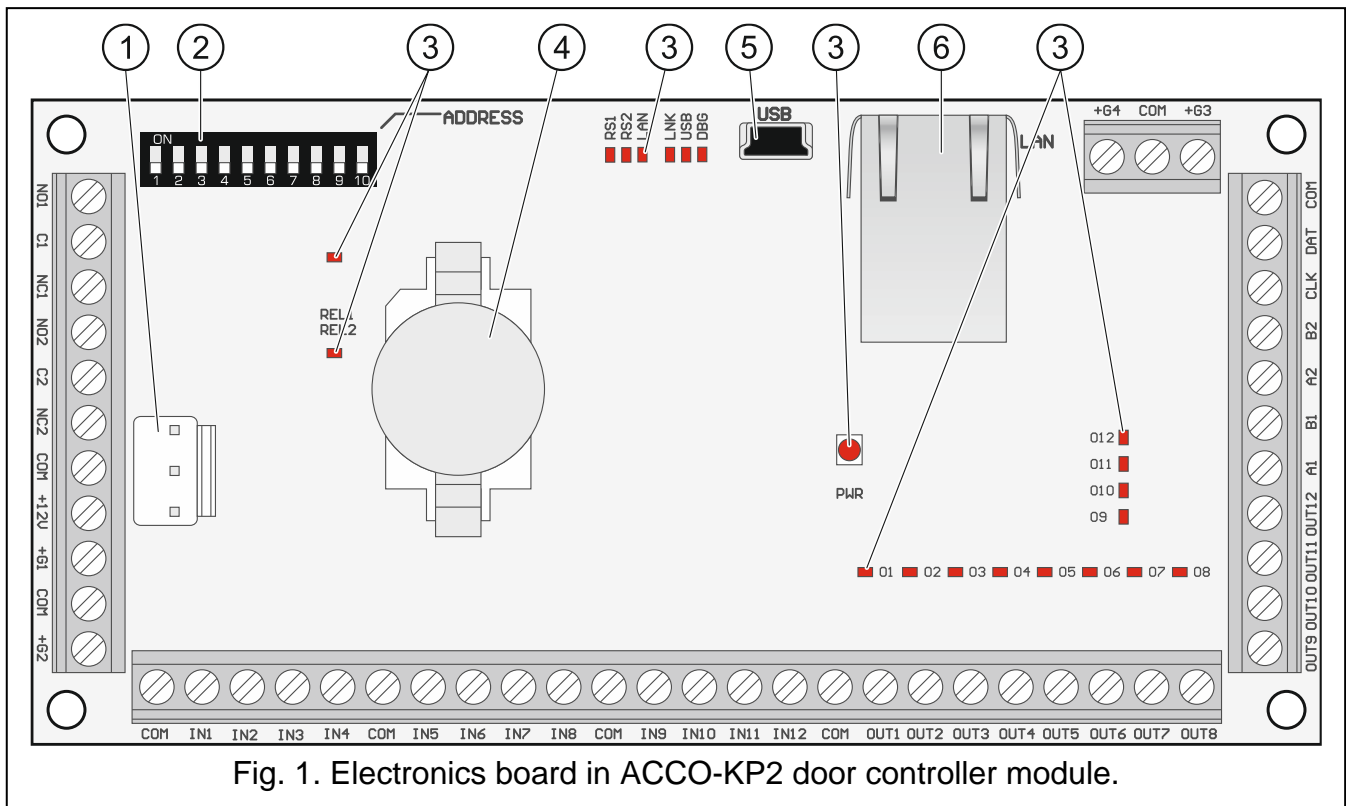

Fig. 1. Electronics board in ACCO-KP2 door controller module.

- ① APS connector for a SATEL power supply unit (e.g. APS-412).
- ② DIP-switches for setting the module address (see “Address setting” p. 3).
- ③ LEDs (REL1 – status of relay output; RS1 – status of RS-485 bus; DBG – identifier used; PWR – power supply status; O1...O12 – output status).
- ④ lithium battery (CR2032 3 V) for clock backup.
- ⑤ USB Micro-B port.
- ⑥ RJ-45 socket for future applications.

Description of terminals

- +12V** – power input (12 VDC \pm 15%),
- COM** – common ground,
- C1** – relay output common contact,
- NO1** – relay output normally open contact,
- NC1** – relay output normally closed contact,
- C2, NO2, NC2** – terminals for future applications,
- IN1** – connecting reader A: data (0) [SIG1A],
- IN2** – connecting reader A: data (1) [SIG2A],
- IN3** – reader A presence control [TMPA],
- IN4** – connecting tamper circuit [ITMP],



If no tamper switch is connected to the IN4 terminal, short the terminal to common ground.

| | |
|---------------------|---|
| IN5 | – connecting reader B: data (0) [SIG1B], |
| IN6 | – connecting reader B: data (1) [SIG2B], |
| IN7 | – reader B presence control [TMPB], |
| IN8 | – programmable input 1, |
| IN9 | – programmable input 2, |
| IN10 | – programmable input 3, |
| IN11 | – programmable input 4, |
| IN12 | – programmable input 5, |
| OUT1 | – reader A sound control [BPA], |
| OUT2 | – reader A green LED control [LD1A], |
| OUT3 | – reader A red LED control [LD2A], |
| OUT4 | – disabling reader A operation [DISA], |
| OUT5 | – reader B sound control [BPB], |
| OUT6 | – reader B green LED control [LD1B], |
| OUT7 | – reader B red LED control [LD2B], |
| OUT8 | – disabling reader B operation [DISB], |
| OUT9...OUT10 | – terminals for future applications, |
| OUT11 | – programmable output 1, |
| OUT12 | – programmable output 2, |
| CLK, DAT | – terminals for connecting LCD keypad or keypad, |
| +G1...+G4 | – terminal power outputs, |
| A1...B1 | – RS-485 bus terminals, |
| A2...B2 | – RS-485 bus terminals for connecting readers and keypads that support the OSDP protocol. |

1.1 Address setting

If the module is to work in the access control system, you must set an individual address in the module.

To set the address, use the DIP-switches on the module electronics board. The switches have numbers assigned to them. In the OFF position, the value is 0. The numbers assigned to the switches in ON position are presented in the table 1. The sum of these numbers is the address set.

Switches 9 and 10 are not used.



Do not set the same address in more than one device.

Do not set address 0 in the module. This address is reserved for the purpose of communication in the system.

| Switch (ON position) | 1 | 2 | 3 | 4 | 5 | 6 | 7 | 8 | 9 | 10 |
|-------------------------|---|---|---|---|----|----|----|-----|---|----|
| Number | 1 | 2 | 4 | 8 | 16 | 32 | 64 | 128 | - | - |

Table 1.

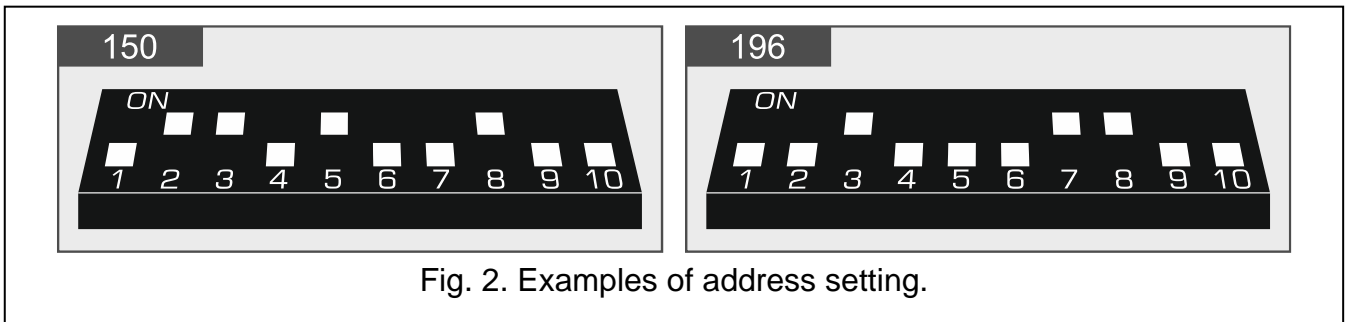

Fig. 2. Examples of address setting.

2. Devices interfacing with the module

For the module to be able to execute the access control functions, it is necessary to connect to the module a user identification device, a device to activate the controlled door and a sensor to monitor the door status.

2.1 User identification devices (terminals)

You can use the following SATEL devices for user identification:

- ACCO-KLCDR keypad,
- ACCO-SCR, CR-MF5 and SO-MF5 keypads,
- CZ-EMM, CZ-EMM2, CZ-EMM3, CZ-EMM4, CR-MF3 or SO-MF3 proximity card readers,
- CZ-DALLAS iButton reader.

The module also works with third-party readers that support the WIEGAND format or the OSDP protocol.

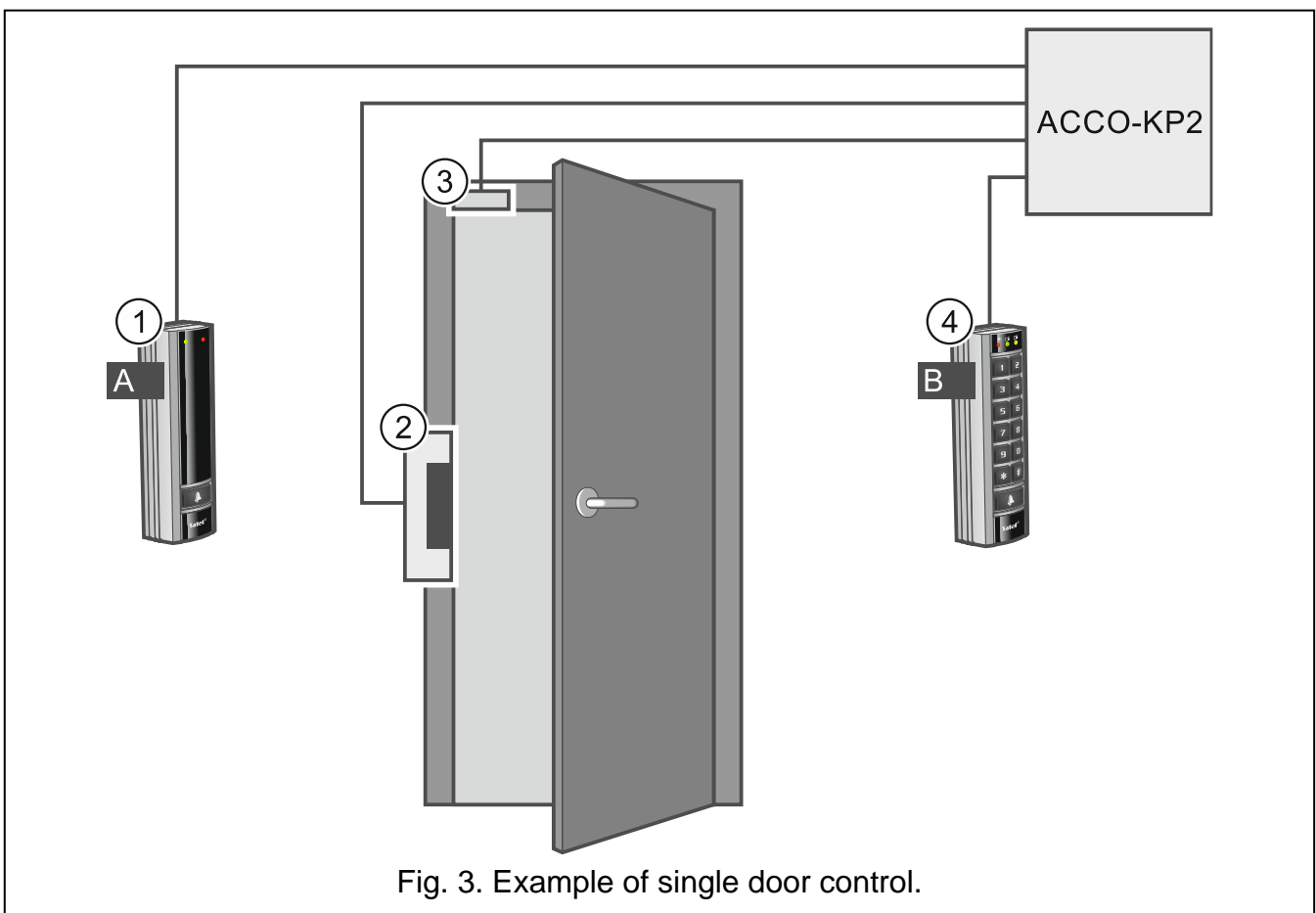

Fig. 3. Example of single door control.

- ① entry terminal (CZ-EMM4 proximity card reader connected as terminal A).
- ② controlled door activator (electric strike controlled from the module relay output).
- ③ door sensor (magnetic contact connected to the module input programmed as “Door status control”).
- ④ exit terminal (ACCO-SCR keypad working as terminal B).

3. Access control module installation

⚠ Disconnect power before making any electrical connections.

The access control module should be installed indoors, in spaces with normal air humidity. The module must be protected against unauthorized access. We recommend to install the controller in a room with controlled access.

i The distance between the terminal units should be no less than 50 cm.

Mounting the terminals on metal surface or in metal enclosure may reduce the range of the readers or even make the proximity card readout entirely impossible.

For connecting the terminals, activators (electric strike, electromagnetic lock) and door sensors, we recommend to use an unshielded non-twisted cable.

Select cross-section of the power supply wires so that the supply voltage drop between the power supply and the supplied device should not exceed 1 V as against the output voltage.

The reader / LCD keypad working as terminal A is treated by the module as the entry terminal. The reader / LCD keypad working as terminal B is treated by the module as the exit terminal.

3.1 Installing and connecting the terminals

Install the terminals (LCD keypads / keypads / readers) in a place that is easily accessible to the users.

i The length of cable connecting the terminal with the module should not exceed:

- LCD keypad / keypad: 300 m,
- reader: 30 m.

3.1.1 Connecting the ACCO-KLCDR keypad

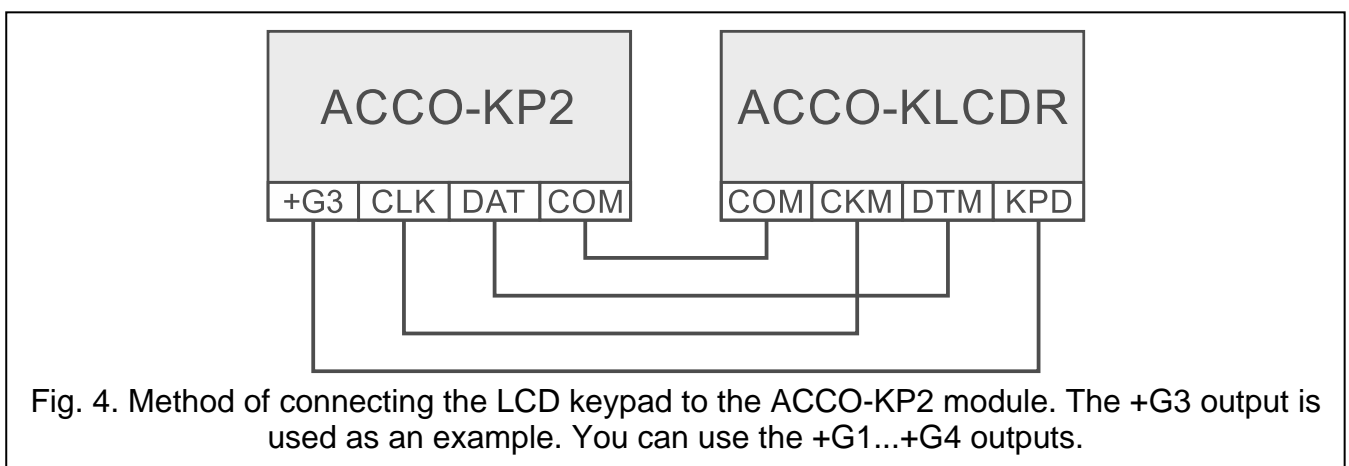







Fig. 4. Method of connecting the LCD keypad to the ACCO-KP2 module. The +G3 output is used as an example. You can use the +G1...+G4 outputs.

The module supports LCD keypads with addresses 0 and 1. See full manual for description of the address setting procedure.

3.1.2 Connecting the ACCO-SCR keypad

| Wire | Description | ACCO-KP2 terminals | |
|--|----------------------------|---|------------|
| | | Terminal A | Terminal B |
|  brown | power supply | +G1...+G4 | |
|  white | common ground | COM | |
|  gray | clock | CLK | |
|  green | data | DAT | |
|  yellow | OC type output (BELL) | IN8...IN12 (input programmed as "Bell signal") | |
|  violet | disabling reader operation | OUT4 | OUT8 |

The module supports keypads with addresses 0 and 1. See full manual for description of the address setting procedure.

3.1.3 Connecting the CR-MF5 and SO-MF5 keypads

ACCO-SCR interface

| CR-MF5 / SO-MF5 keypad terminals | ACCO-KP2 terminals | |
|----------------------------------|---|----------|
| | Reader A | Reader B |
| DATA/D1 | DTA | |
| +12V | +G1...+G4 | |
| COM | COM | |
| CLK/D0 | CLK | |
| BELL | IN8...IN12 (input programmed as "Bell signal") | |











RS-485 bus (OSDP)

 The RS-485 bus may be up to 1200 m long.

| CR-MF5 / SO-MF5 keypad terminals | ACCO-KP2 terminals | |
|----------------------------------|---|----------|
| | Reader A | Reader B |
| +12V | +G1...+G4 | |
| COM | COM | |
| RSA | A2 | |
| RSB | B2 | |
| BELL | IN8...IN12 (input programmed as "Bell signal") | |

The module only supports keypads with addresses 0 and 1. For instructions on how to change the address, please refer to the keypad manual.

3.1.4 Connecting the CZ-EMM, CZ-EMM2, CZ-EMM3 and CZ-EMM4 readers

| Wire | Description | ACCO-KP2 terminals | |
|--|------------------------------------|---|------------|
| | | Terminal A | Terminal B |
|  red | power supply | +G1...+G4 | |
|  green | data (0) | IN1 | IN5 |
|  black | data (1) [CZ-EMM3 and CZ-EMM4] | <i>do not connect</i> | |
|  blue | common ground | COM | COM |
|  yellow | sonder | OUT1 | OUT5 |
|  pink | green LED | OUT2 | OUT6 |
|  gray | red LED | OUT3 | OUT7 |
|  brown | disabling reader operation | OUT4 | OUT8 |
|  white | presence control | IN3 | IN7 |
|  violet | OC type output (BELL) [CZ-EMM4] | IN8...IN12 (input programmed as "Bell signal") | |



The black wire is used when the CZ-EMM3 and CZ-EMM4 readers are working in the Wiegand format. It is recommended that the readers use the EM-Marine interface.

3.1.5 Connecting the CR-MF3 and SO-MF3 readers



If you are connecting the reader using the EM-Marine or Wiegand interface, program the IN1...IN3 inputs following the instructions in the reader manual.

EM-Marine interface

| CR-MF3 / SO-MF3 reader terminals | ACCO-KP2 controller terminals | |
|----------------------------------|-------------------------------|----------|
| | Reader A | Reader B |
| TMP | IN3 | IN7 |
| +12V | +G1...+G4 | |
| COM | COM | |
| CLK/D0 | IN1 | IN5 |
| IN1 | OUT3 | OUT7 |
| IN2 | OUT2 | OUT6 |
| IN3 | OUT1 | OUT5 |

Wiegand interface

| CR-MF3 / SO-MF3 reader terminals | ACCO-KP2 controller terminals | |
|----------------------------------|-------------------------------|----------|
| | Reader A | Reader B |
| DATA/D1 | IN2 | IN6 |
| TMP | IN3 | IN7 |
| +12V | +G1...+G4 | |
| COM | COM | |
| CLK/D0 | IN1 | IN5 |
| IN1 | OUT3 | OUT7 |
| IN2 | OUT2 | OUT6 |
| IN3 | OUT1 | OUT5 |

RS-485 bus (OSDP)







The RS-485 bus may be up to 1200 m long.

| CR-MF3 / SO-MF3 reader terminals | ACCO-KP2 terminals | |
|----------------------------------|--------------------|----------|
| | Reader A | Reader B |
| RSA | A2 | |
| RSB | B2 | |
| +12V | +G1...+G4 | |
| COM | COM | |

3.1.6 Connecting a third-party reader

| Function | ACCO-KP2 terminals | |
|----------------------------|--------------------|------------|
| | Terminal A | Terminal B |
| power supply | +G1...+G4 | |
| data (0) | IN1 | IN5 |
| data (1) | IN2 | IN6 |
| common ground | COM | COM |
| sounder | OUT1 | OUT5 |
| green LED | OUT2 | OUT6 |
| red LED | OUT3 | OUT7 |
| disabling reader operation | OUT4 | OUT8 |
| presence control | IN3 | IN7 |

3.1.7 Connecting the DALLAS iButton reader

| Wire | Description | ACCO-KP2 terminals | |
|--|-----------------|--------------------|------------|
| | | Terminal A | Terminal B |
|  brown | red LED anode | OUT3 | OUT7 |
|  white | data | IN1 | IN5 |
|  gray | common ground | COM | COM |
|  green | green LED anode | OUT2 | OUT6 |
|  yellow | LED cathode | COM | COM |

3.2 Connecting activators and door sensors

1. Connect the device which is to activate the door to the relay output. Depending on the device type, use the NO or NC terminal. It is not recommended that the door actuator be powered from the same source as the module.
2. Connect the sensor monitoring the door status to one of the module inputs.



By default, the input IN8 is programmed as the “Door status control”, NO type. However, you can select any of the programmable inputs and configure it accordingly.

3.3 Connecting the power supply and starting the module



Do not connect power supply until the installation work is completed.

The ACCO-KP2 module requires power supply of 12 VDC ($\pm 15\%$). SATEL offers power supplies (e.g. APS-412), which can be connected to the APS connector on the electronics board.

1. Depending on the selected method of module powering, connect the power supply unit to the APS connector or connect the power leads to the +12V and COM terminals.



Never connect power supply to APS connector and terminals at the same time.

2. Power up the module. The module will start up.