

Access control module ACCO

# ACCO-KP2

Firmware version 1.01

EN



INSTALLER MANUAL

acco-kp2\_i\_en 10/24

**Satel** ®

SATEL sp. z o.o. • ul. Budowlanych 66 • 80-298 Gdańsk • POLAND  
tel. +48 58 320 94 00  
[www.satel.pl](http://www.satel.pl)

## IMPORTANT

The device should be installed by qualified personnel.

Prior to installation, please read carefully this manual.

Changes, modifications or repairs not authorized by the manufacturer shall void your rights under the warranty.

In this device we used:

- Keil RTX5 – under Apache 2.0 license (<https://www2.keil.com/mdk5/cmsis/rtx>)
- 1wIP – under BSD license (<https://savannah.nongnu.org/projects/1wip>).

SATEL aims to continually improve the quality of its products, which may result in changes in their technical specifications and software. Current information about the changes being introduced is available on our website.

Please visit us at:  
<https://support.satel.pl>

The declaration of conformity may be consulted at [www.satel.pl/ce](http://www.satel.pl/ce)

### Signs in this manual



Caution – information on the safety of users, devices, etc.



Note – suggestion or additional information.

## CONTENTS

|  |    |
|--|----|
| 1. Introduction.....   | 2  |
| 2. Features .....  | 2  |
| 3. Electronics board.....  | 4  |
| 3.1 Description of LEDs.....   | 5  |
| 3.2 Address setting .....  | 6  |
| 4. Devices interfacing with the module .....                             | 6  |
| 4.1 User identification devices (terminals).....                         | 6  |
| 4.1.1 ACCO-KLCDR keypad .....  | 6  |
| 4.1.2 ACCO-SCR keypad with proximity card reader .....                   | 7  |
| 4.1.3 CR-MF5 and SO-MF5 keypads with MIFARE proximity card reader .....  | 8  |
| 4.1.4 CZ-EMM and CZ-EMM2 proximity card readers.....                     | 9  |
| 4.1.5 CZ-EMM3 and CZ-EMM4 proximity card readers.....                    | 9  |
| 4.1.6 CR-MF3 and SO-MF3 MIFARE proximity card readers.....               | 10 |
| 4.1.7 CZ-DALLAS iButton reader .....                                     | 11 |
| 4.1.8 Third-party Wiegand readers .....                                  | 11 |
| 5. Access control module installation .....                              | 12 |
| 5.1 Installing and connecting the terminals .....                        | 13 |
| 5.1.1 Installing and connecting the ACCO-KLCDR keypad .....              | 13 |
| 5.1.2 Installing and connecting the ACCO-SCR keypad.....                 | 14 |
| 5.1.3 Connecting the CR-MF5 and SO-MF5 keypads .....                     | 15 |
| 5.1.4 Connecting the CZ-EMM, CZ-EMM2, CZ-EMM3 and CZ-EMM4 readers .....  | 17 |
| 5.1.5 Connecting the CR-MF3 and SO-MF3 readers .....                     | 18 |
| 5.1.6 Connecting the third-party reader .....                            | 19 |
| 5.1.7 Connecting the DALLAS iButton reader .....                         | 19 |
| 5.2 Connecting activators and door sensors .....                         | 20 |
| 5.3 Mantrap / airlock.....   | 20 |
| 5.4 Connecting the power supply and starting the module.....             | 21 |
| 6. Module in the access control system.....                              | 22 |
| 6.1 Access control system without control panel (ACCO) .....             | 22 |
| 6.2 Access control system with the ACCO-NT control panel (ACCO NET)..... | 22 |
| 7. Specifications .....  | 23 |
| 7.1 ACCO-KP2 module .....  | 23 |
| 7.2 ACCO-KLCDR keypad.....   | 23 |
| 7.3 ACCO-SCR keypad with proximity card reader.....                      | 23 |

## 1. Introduction

---

The ACCO-KP2 module is used to control access to a single door. This manual describes the access control module (electronics version 3.8) and how to install it. This manual also provides information on the devices that work with the module and how to connect them.

## 2. Features

---

### User identification

- Ability to connect up to two terminals.
- Support for different terminals to enable user identification:
  - ACCO-KLCDR keypad: proximity card / code,
  - ACCO-SCR, CR-MF5 and SO-MF5 keypads: proximity card / code,
  - CZ-EMM, CZ-EMM2, CZ-EMM3, CZ-EMM4, CR-MF3 and SO-MF3 readers: proximity card,
  - CZ-DALLAS reader: DALLAS iButton,
  - third-party readers that send data in the Wiegand format,
  - third-party readers that support the OSDP protocol.

### Inputs

- 5 programmable inputs:
  - support for devices with NO and NC type outputs,
  - different input types.
- Additional inputs for:
  - connecting the readers,
  - controlling the presence of the readers,
  - connecting the tamper circuit.
- Power input.

### Outputs

- 2 programmable outputs:
  - low-current OC type outputs,
  - different output types.
- Additional outputs for connecting the readers.
- Relay output for controlling electric strike, electromagnetic lock, gate controller or other devices which activate the door.
- 4 power outputs (0.5 A / 12 VDC).

### Event log

- Over 24 thousand events.
- Recording of work time information.

### Users

- Up to 1024 users.

- User can be assigned:
  - code,
  - proximity card (passive transponder in the form of card, key tag),
  - DALLAS iButton.
- User rights to define the extent of door access.

### **Time schedules**

- Up to 256 weekly schedules.
- Up to 256 daily schedules.
- Up to 256 time slots.

### **Additional features**

- Capability to block or unblock the door:
  - by the user,
  - in case of fire or burglary,
  - automatically, according to access calendar.
- “Anti-passback” function to prevent any attempts of repeated entry or exit by using the same identifier.
- Capability to update module firmware.

### **Programming**

- Programming in the ACCO-SOFT-LT program installed on a computer connected to the RS-485 bus by means of the ACCO-USB converter.

### **RS-485**

- Capability to build an access control system based only on access control modules, i.e. the ACCO system:
  - up to 255 modules in the system,
  - modules as stand-alone devices (all data necessary for work is stored in their memory),
  - modules in the system configured using the ACCO-USB converter.
- Capability to connect to the ACCO-NT access control panel – work in the ACCO NET system.
- Capability to connect readers and keypads that use the OSDP protocol for communication (module firmware version 1.01 or newer) – work in the ACCO NET system.

### **Mainboard**

- USB Micro-B port to enable firmware update.
- Clock with battery backup.
- LEDs to indicate:
  - the status of communication between module and computer,
  - the power supply status,
  - the receipt of identifier information,
  - the relay status,
  - the status of outputs.
- Connector for SATEL power supply unit.

### 3. Electronics board

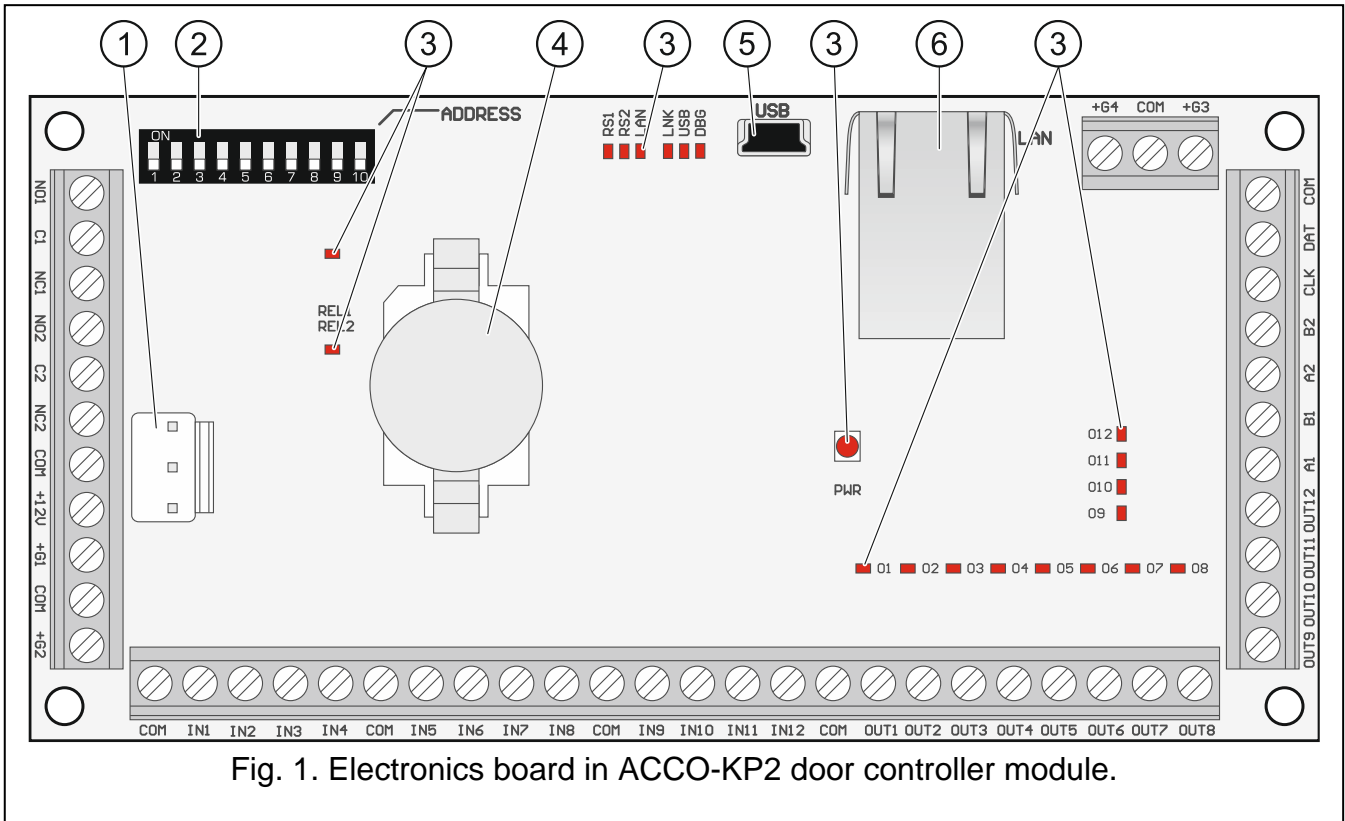

Fig. 1. Electronics board in ACCO-KP2 door controller module.

- ① APS connector for a SATEL power supply unit (e.g. APS-412).
- ② DIP-switches for setting the module address (see “Address setting” p. 6).
- ③ LEDs (see “Description of LEDs”).
- ④ lithium battery (CR2032 3 V) for clock backup.
- ⑤ USB Micro-B port.
- ⑥ RJ-45 socket for future applications.

#### Description of terminals

- +12V** – power input (12 VDC  $\pm$ 15%),
- COM** – common ground,
- C1** – relay output common contact,
- NO1** – relay output normally open contact,
- NC1** – relay output normally closed contact,
- C2, NO2, NC2** – terminals for future applications,
- IN1** – connecting reader A: data (0) [SIG1A],
- IN2** – connecting reader A: data (1) [SIG2A],
- IN3** – reader A presence control [TMPA],
- IN4** – connecting tamper circuit [ITMP],



*If no tamper switch is connected to the IN4 terminal, short the terminal to common ground.*

- IN5** – connecting reader B: data (0) [SIG1B],
- IN6** – connecting reader B: data (1) [SIG2B],

|                     |   |
|---------------------|---|
| <b>IN7</b>          | – reader B presence control [TMPB],   |
| <b>IN8</b>          | – programmable input 1,   |
| <b>IN9</b>          | – programmable input 2,   |
| <b>IN10</b>         | – programmable input 3,   |
| <b>IN11</b>         | – programmable input 4,   |
| <b>IN12</b>         | – programmable input 5,   |
| <b>OUT1</b>         | – reader A sound control [BPA],   |
| <b>OUT2</b>         | – reader A green LED control [LD1A],  |
| <b>OUT3</b>         | – reader A red LED control [LD2A],  |
| <b>OUT4</b>         | – disabling reader A operation [DISA],  |
| <b>OUT5</b>         | – reader B sound control [BPB],   |
| <b>OUT6</b>         | – reader B green LED control [LD1B],  |
| <b>OUT7</b>         | – reader B red LED control [LD2B],  |
| <b>OUT8</b>         | – disabling reader B operation [DISB],  |
| <b>OUT9...OUT10</b> | – terminals for future applications,  |
| <b>OUT11</b>        | – programmable output 1,  |
| <b>OUT12</b>        | – programmable output 2,  |
| <b>CLK, DAT</b>     | – terminals for connecting LCD keypad or keypad,  |
| <b>+G1...+G4</b>    | – terminal power outputs,   |
| <b>A1...B1</b>      | – RS-485 bus terminals,   |
| <b>A2...B2</b>      | – RS-485 bus terminals for connecting readers and keypads that support the OSDP protocol. |

### 3.1 Description of LEDs

---

#### REL1

ON – relay output 1 turned on;  
 OFF – relay output 1 turned off.

#### RS1

flashing – communication via RS-485 port in progress;  
 OFF – no communication via RS-485 port.

#### REL2 / RS2 / LAN / LNK

LEDs for future applications.

#### USB

ON – computer connected to USB port;  
 flashing – data transmission via USB port;  
 OFF – computer not connected to USB port.

#### DBG

1 flash (around 200 ms) – identifier information received from terminal (e.g. card / DALLAS iButton / key tag).

#### PWR

ON – power ON;  
 OFF – power OFF.

## O1...O12

LEDs indicate the status of outputs.

### 3.2 Address setting

If the module is to work in the access control system, you must set an individual address in the module.

To set the address, use the DIP-switches on the module electronics board. The switches have numbers assigned to them. In the OFF position, the value is 0. The numbers assigned to the switches in ON position are presented in the table 1. The sum of these numbers is the address set.

Switches 9 and 10 are not used.



*Do not set the same address in more than one device.*

*Do not set address 0 in the module. This address is reserved for the purpose of communication in the system.*

| Switch<br>(ON position) | 1 | 2 | 3 | 4 | 5  | 6  | 7  | 8   | 9 | 10 |
|-------------------------|---|---|---|---|----|----|----|-----|---|----|
| Number                  | 1 | 2 | 4 | 8 | 16 | 32 | 64 | 128 | - | -  |

Table 1.

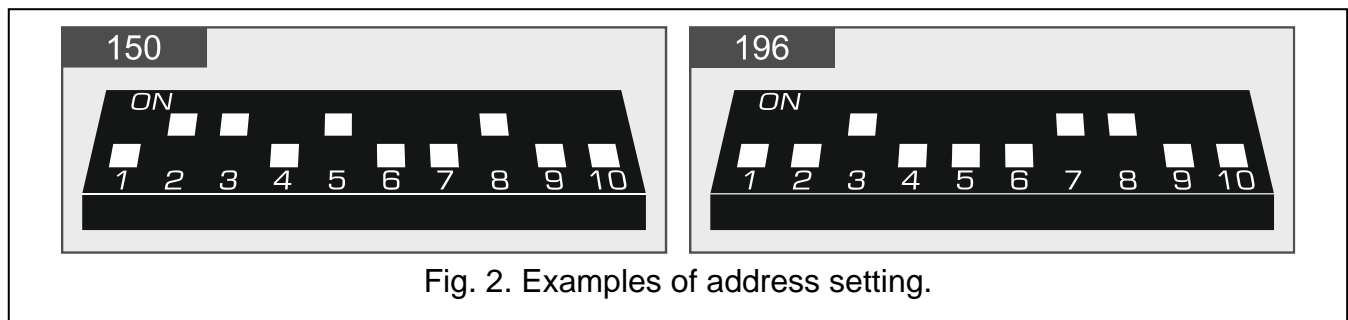

Fig. 2. Examples of address setting.

## 4. Devices interfacing with the module

For the module to be able to execute the access control functions, it is necessary to connect to the module a user identification device, a device to activate the controlled door and a sensor to monitor the door status.

### 4.1 User identification devices (terminals)

#### 4.1.1 ACCO-KLCDR keypad

- Display: 2 x 16 characters with backlight.
- Keys for entering the code.
- Built-in proximity card reader.
- Support for cards, key tags and other 125 kHz passive transponders.
- LED indicators to indicate the door / module status.
- Backlit keys.
- Built-in sounder.
- Tamper protection against enclosure opening and removal from the wall.

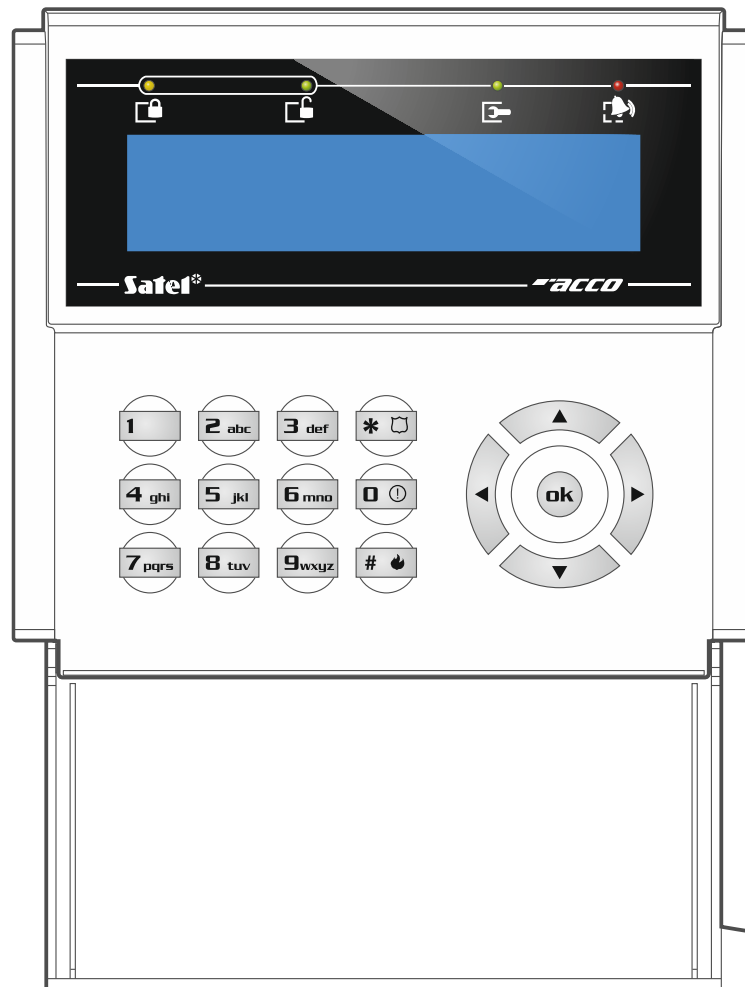



Fig. 3. ACCO-KLCCR keypad.

#### 4.1.2 ACCO-SCR keypad with proximity card reader



Fig. 4. ACCO-SCR keypad.

- Keys for entering the code.
- Built-in proximity card reader.
- Support for cards, key tags and other 125 kHz passive transponders.
- Bell key.
- OC type output (BELL) controlled by the  key.
- LED indicators to indicate the door / module status.
- Backlit keys.
- Built-in sounder.
- Tamper protection against enclosure opening and removal from the wall.
- Suitable for outdoor installation (weatherproof enclosure).

#### 4.1.3 CR-MF5 and SO-MF5 keypads with MIFARE proximity card reader

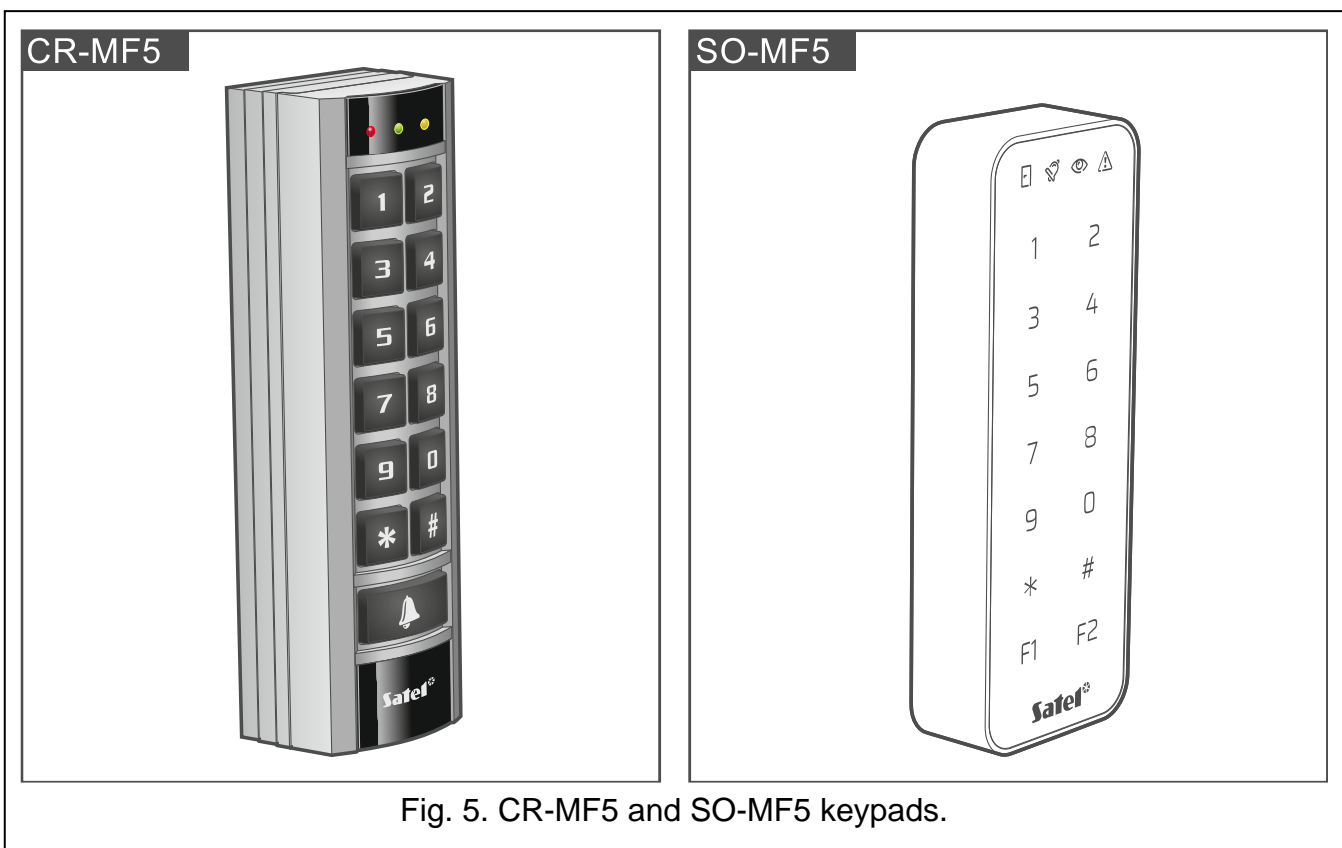

- Keys for entering the code.
- Built-in MIFARE® proximity card reader.
- Support for cards, key tags and other MIFARE 13.56 MHz passive transponders.
- Support for OSDP protocol (RS-485 bus).
- Available connection methods:
  - RS-485 bus (OSDP),
  - ACCO-SCR interface.
- Programming in the CR SOFT program.
- Function key [CR-MF5] / 2 function keys [SO-MF5].
- OC type output (BELL) controlled by the  [CR-MF5] / F1 [SO-MF5] key.
- LED indicators to indicate the door / module status.
- Backlit keys.

- Built-in sounder.
- Tamper protection against enclosure opening and removal from the wall.
- CR-MF5 keypad suitable for outdoor installation (weatherproof enclosure).



*To program MIFARE® cards, the SO-PRG programmer is required.*

#### 4.1.4 CZ-EMM and CZ-EMM2 proximity card readers

- Support for cards, key tags and other 125 kHz passive transponders.
- EM-Marine communication interface.
- Bicolor LED to indicate the door / reader status.
- Built-in sounder.

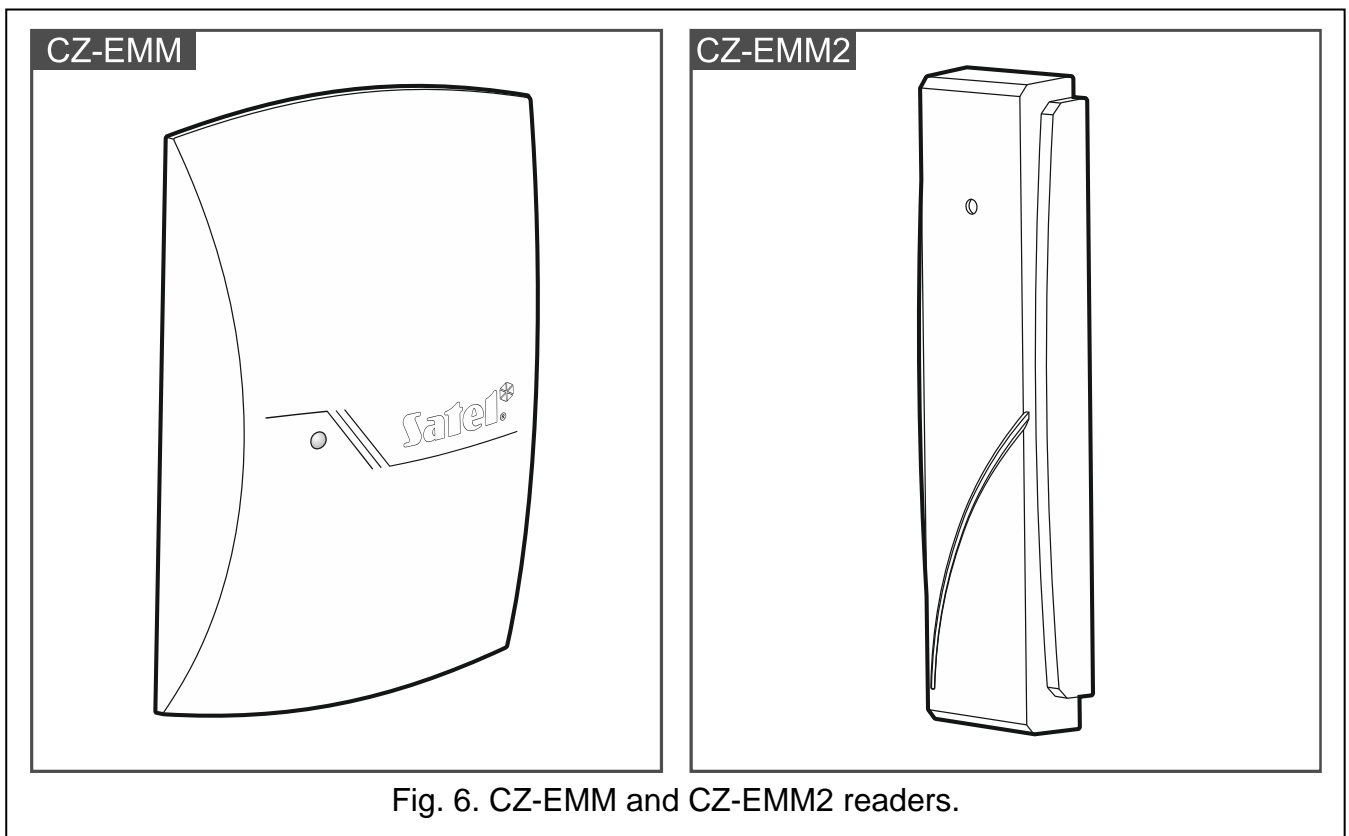

#### 4.1.5 CZ-EMM3 and CZ-EMM4 proximity card readers

- Support for cards, key tags and other 125 kHz passive transponders.
- EM-Marine or Wiegand 26 communication interface.
- LED indicators to indicate the door / reader status.
- Built-in sounder.
- Bell key [CZ-EMM4 only].
- OC type output controlled directly from the keypad (BELL) [CZ-EMM4 only].
- Suitable for outdoor installation (weatherproof enclosure).



*It is recommended that the CZ-EMM3 and CZ-EMM4 readers use the EM-Marine interface.*

*The card holding feature is not available for the CZ-EMM3 and CZ-EMM4 readers using the Wiegand interface.*

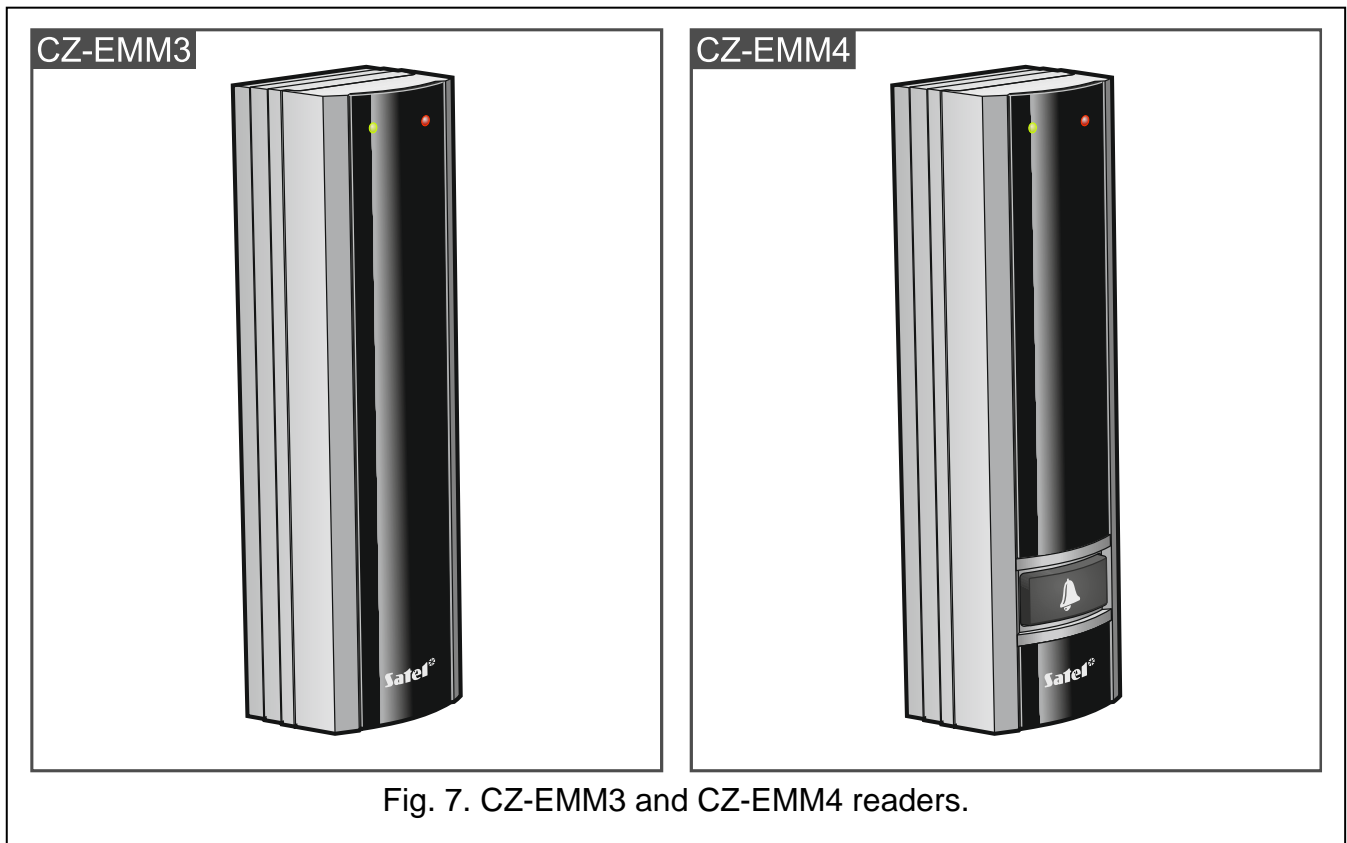

#### 4.1.6 CR-MF3 and SO-MF3 MIFARE proximity card readers

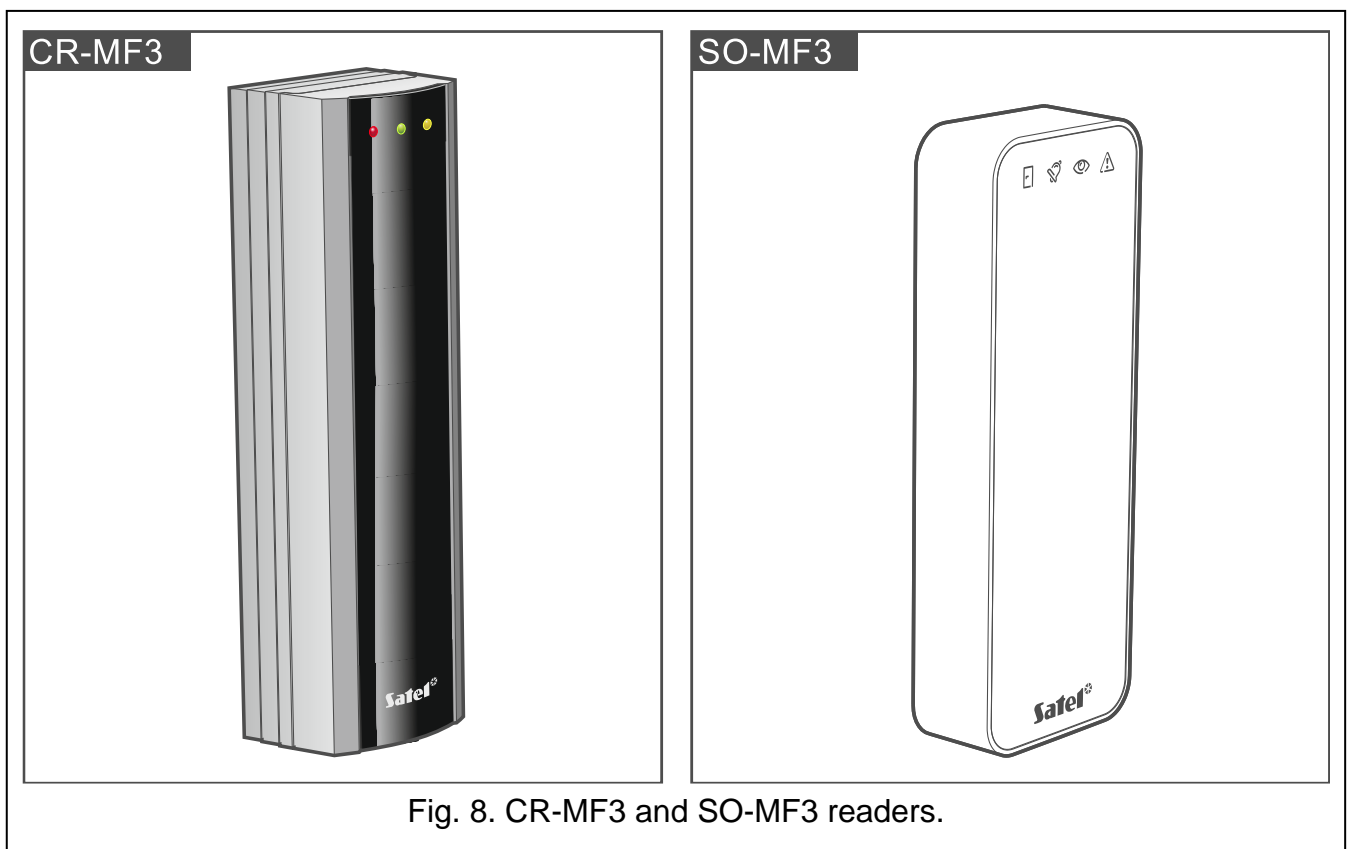

- Support for cards, key tags and other MIFARE 13.56 MHz passive transponders.
- Support for OSDP protocol (RS-485 bus).

- Available connection methods:
  - RS-485 bus (OSDP),
  - EM-Marine interface,
  - Wiegand interface.
- LED indicators to indicate the door and module status.
- Built-in sounder.
- Programming in the CR SOFT program.
- Tamper protection against enclosure opening and removal from the wall.
- CR-MF3 keypad suitable for outdoor installation (weatherproof enclosure).



*To program MIFARE® cards, the SO-PRG programmer is required.*

#### 4.1.7 CZ-DALLAS iButton reader

- DALLAS iButton support.
- Bicolor LED to indicate the door / reader status.
- Installation directly on the wall or door frame.
- Suitable for outdoor installation (weatherproof enclosure).

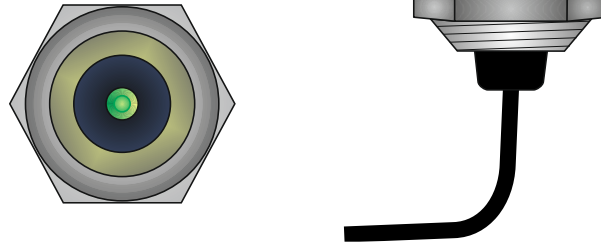

Fig. 9. CZ-DALLAS reader.

#### 4.1.8 Third-party Wiegand readers

Supported Wiegand transmission formats:

- 26 bit – parity bit (even) + card number (24 bits) + parity bit (odd); byte order: from MSB to LSB;
- 32 bit – card number (32 bits) without parity check; byte order: from MSB to LSB;
- 34 bit – parity bit (even) + card number (32 bits) + parity bit (odd); byte order: from MSB to LSB;
- 36 bit – parity bit (even) + card number (34 bits) + parity bit (odd); byte order: from MSB to LSB;
- 40 bit – card number (40 bits) without parity check; byte order: from MSB to LSB;
- 42 bit – parity bit (even) + card number (40 bits) + parity bit (odd); byte order: from MSB to LSB;
- 56 bit – card number (56 bits) without parity check; byte order: from LSB to MSB; the controller uses the 5 oldest bytes received and rejects the other ones.



*For Wiegand readers, using the same identifier twice within 4 seconds is interpreted as holding the card. Not all readers will support this feature. Please check your readers for this feature.*

## 5. Access control module installation



**Disconnect power before making any electrical connections.**

The access control module should be installed indoors, in spaces with normal air humidity. The module must be protected against unauthorized access. We recommend to install the controller in a room with controlled access.



*The distance between the terminal units should be no less than 50 cm.*

*Mounting the terminals (LCD keypads with proximity card reader, keypads with proximity card reader, readers) on metal surface or in metal enclosure may result in reduction of the reader range or even make the proximity card readout entirely impossible.*

For connecting the terminals, activators (electric strike, electromagnetic lock) and door sensors, we recommend to use an unshielded non-twisted cable.

Select the cross-section of the power supply wires so that the supply voltage drop between the power supply and the supplied device does not exceed 1 V as against the output voltage.

The reader / LCD keypad working as terminal A is treated by the module as the entry terminal. The reader / LCD keypad working as terminal B is treated by the module as the exit terminal.

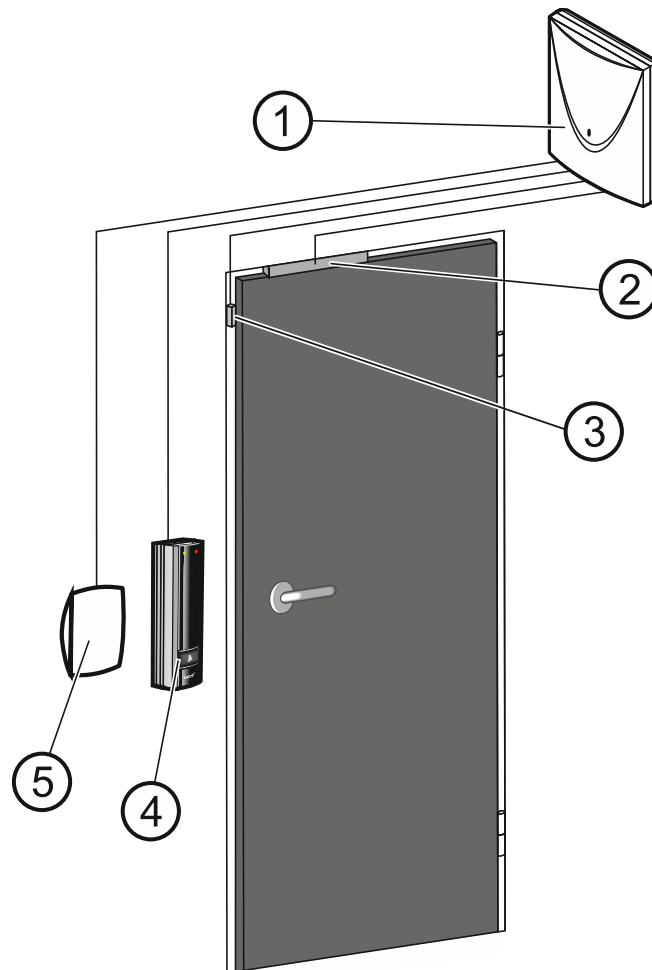

Fig. 10. Example of access control installation.

Explanations for Fig. 10:

- ① access control module.
- ② controlled door activator (electromagnetic lock controlled from the module relay output).
- ③ door sensor (magnetic contact connected to the module input programmed as "Door status control").
- ④ entry terminal (proximity card reader connected as terminal A).
- ⑤ exit terminal (proximity card reader connected as terminal B).

## 5.1 Installing and connecting the terminals

Install the terminals (LCD keypads / keypads / readers) in a place that is easily accessible to the users.

### 5.1.1 Installing and connecting the ACCO-KLCDR keypad



*The length of cable connecting the LCD keypad with the module should not exceed 300 m.*

The LCD keypad is designed for indoor installation.

1. Open the LCD keypad enclosure.
2. Place the enclosure base on the wall and mark the location of mounting holes.
3. Drill the holes for wall plugs (anchors).
4. Run the wires through the opening in the enclosure base.
5. Use wall plugs (anchors) and screws to secure the enclosure base to the wall. Select wall plugs and screws specifically intended for the mounting surface (different for concrete or brick wall, different for plaster wall or wood, etc.).
6. Connect the LCD keypad terminals to the appropriate module terminals (see Fig. 11).
7. Put the cover on the catches and snap the enclosure shut.



*If the clock and additional information fail to appear on the LCD keypad display after power-up, make sure that:*

- *the cables connecting the LCD keypad to the module have been properly connected;*
- *a correct address is set in the LCD keypad.*

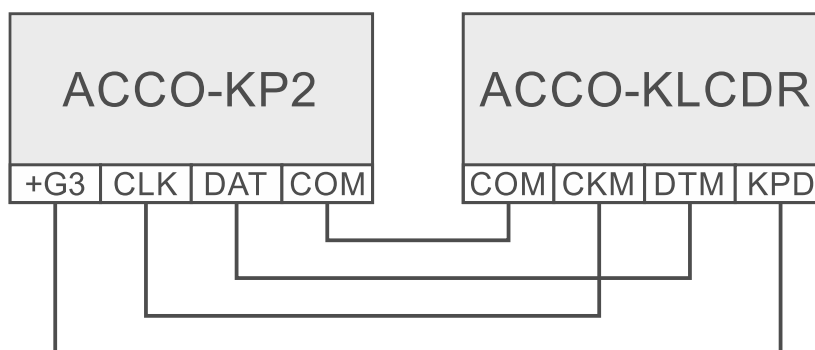

Fig. 11. Method of connecting the LCD keypad to the ACCO-KP2 module. The +G3 output is used as an example. You can use the +G1...+G4 outputs.

## Setting the LCD keypad address



The module supports LCD keypads with addresses 0 and 1. The LCD keypad with address 0 will serve as terminal A (entry). The LCD keypad with address 1 will serve as terminal B (exit).

If you want to check whether the LCD keypad serves as an entry or exit terminal, restart the LCD keypad by holding down the ▲ and ▼ keys for around 10 seconds. Letter A (terminal A) or B (terminal B) will be displayed.

Connecting the LCD keypad with address 0 will switch off the proximity card reader working as terminal A. Connecting the LCD keypad with address 1 will switch off the proximity card reader working as terminal B.

Never connect two devices (LCD keypads, keypads) that have the same address.

1. Power off the LCD keypad.
2. Disconnect the wires from the LCD keypad terminals CKM and DTM.
3. Short together the LCD keypad terminals CKM and DTM.
4. Power on the LCD keypad.
5. Information about the current address and the permissible address range will be displayed on the LCD keypad screen (see Fig. 12).

The image shows a monochrome LCD display with a black border. The text on the screen is arranged in two lines. The first line reads 'This LCD address' and the second line reads '(n, 0-7): 0'. The 'n' is a small character, and the '0' at the end is a larger digit.

Fig. 12. Programming the LCD keypad address (n = current address).

6. Press the key 0 or 1.
7. Power off the LCD keypad.
8. Open the LCD keypad terminals CKM and DTM.
9. Correctly connect the wires to the LCD keypad terminals CKM and DTM.
10. Power on the LCD keypad.

### 5.1.2 Installing and connecting the ACCO-SCR keypad



The length of cable connecting the keypad with the module should not exceed 300 m.

The keypad is designed for both indoor and outdoor installation.

1. Open the keypad enclosure.
2. Place the enclosure base on the wall and mark the location of mounting holes.
3. Drill the holes for wall plugs (anchors).
4. Use wall plugs (anchors) and screws to secure the enclosure base to the wall. Select wall plugs specifically intended for the mounting surface (different for concrete or brick wall, different for plaster wall, etc.).
5. Close the enclosure and secure it with the screw.
6. Connect the keypad wires to the module as shown in Table 2.
7. You can connect the yellow wire (BELL output) to the module input programmed as "Bell signal".







| Wire   | Description                | ACCO-KP2 terminals                                |            |
|--|----------------------------|---|------------|
|  |                            | Terminal A  | Terminal B |
|  brown  | power                      | +G1...+G4   |            |
|  white  | common ground              | COM   |            |
|  gray   | clock                      | CLK   |            |
|  green  | data                       | DAT   |            |
|  yellow | OC type output (BELL)      | IN8...IN12<br>(input programmed as "Bell signal") |            |
|  violet | disabling reader operation | OUT4  | OUT8       |

Table 2. Method of connecting the keypad to the module.



*The violet wire is provided in keypads with firmware version 2.01 or later.*

*The BELL output is controlled by the bell key. Pressing the key will short the output to common ground.*



### Setting the keypad address



*The module supports keypads with addresses 0 and 1. The keypad with address 0 will serve as terminal A (entry terminal). The keypad with address 1 will serve as terminal B (exit terminal).*

*Connecting the keypad with address 0 will switch off the proximity card reader working as terminal A. Connecting the keypad with address 1 will switch off the proximity card reader working as terminal B.*

*Never connect two devices (LCD keypads, keypads) that have the same address.*

1. Disconnect the brown, gray and green wires from the module terminals.
2. Short the ends of gray and green wires.
3. Reconnect the brown wire to the power output (+G1...+G4). After power on, the  and  LEDs will start flashing alternately (then the ends of gray and green wire may be separated).
4. Press in turn the keys **1** and **#**. The  LED will start flashing.
5. Depending on which address is to be set in the keypad, press **0** or **1** and confirm with the **#** key.
6. Disconnect the brown wire from the power output.
7. Correctly connect to the module the following wires: gray (CLK), green (DAT) and brown (+G1...+G4).

#### 5.1.3 Connecting the CR-MF5 and SO-MF5 keypads



*The BELL output of the CR-MF5 keypad is controlled by the  key, and of the SO-MF5 keypad – by the F1 key. When you press the key, the output will be shorted to common ground.*

### ACCO-SCR interface

**i** *If the ACCO-SCR interface is to be used, program the CR-MF5 / SO-MF5 keypad in the CR SOFT program before it is connected to the module. For details on how to program and install the keypads, please refer to their manuals.*

*The length of cable connecting the keypad with the module should not exceed 300 m.*

If the CR-MF5 / SO-MF5 keypad is to use the ACCO-SCR interface, connect it to the module as shown in the table below.

| CR-MF5 / SO-MF5 keypad terminals | ACCO-KP2 terminals                                |          |
|----------------------------------|---|----------|
|                                  | Reader A  | Reader B |
| DATA/D1                          | DTA   |          |
| +12V                             | +G1...+G4   |          |
| COM                              | COM   |          |
| CLK/D0                           | CLK   |          |
| BELL                             | IN8...IN12<br>(input programmed as "Bell signal") |          |

Table 3. Method of connecting the CR-MF5 and SO-MF5 keypads to the module using the ACCO-SCR interface.

### RS-485 bus (OSDP)

**i** *The keypad can be connected to the RS-485 bus if the module is working in the ACCO NET system.*

*The RS-485 bus may be up to 1200 m long.*

If the CR-MF5 / SO-MF5 keypad is to use the OSDP protocol, connect it to the module as shown in the table below.

| CR-MF5 / SO-MF5 keypad terminals | ACCO-KP2 terminals                                |          |
|----------------------------------|---|----------|
|                                  | Reader A  | Reader B |
| +12V                             | +G1...+G4   |          |
| COM                              | COM   |          |
| RSA                              | A2  |          |
| RSB                              | B2  |          |
| BELL                             | IN8...IN12<br>(input programmed as "Bell signal") |          |

Table 4. Method of connecting the CR-MF5 and SO-MF5 keypads to the module using the RS-485 bus (OSDP).

### Setting the keypad address

**i** *Set the address if the keypad uses the ACCO-SCR interface. If the keypad is connected to the RS-485 bus (work in the ACCO NET system), you do not have to set the address. The keypad's serial number is used to select the entry / exit terminal.*

## ACCO-SCR interface



The module supports keypads with addresses 0 and 1. The keypad with address 0 will serve as terminal A (entry terminal). The keypad with address 1 will serve as terminal B (exit terminal).

Connecting the keypad with address 0 will turn off the proximity card reader operating as terminal A. Connecting the keypad with address 1 will turn off the proximity card reader operating as terminal B.

Do not connect two devices (LCD keypads, keypads) with the same address.

You can program the CR-MF5 and SO-MF5 keypad addresses in the CR SOFT program. For detailed instructions, please refer to the keypad manuals.

### 5.1.4 Connecting the CZ-EMM, CZ-EMM2, CZ-EMM3 and CZ-EMM4 readers

Connect the CZ-EMM, CZ-EMM2, CZ-EMM3 and CZ-EMM4 readers as shown in Table 5.



The length of cable connecting the reader with the module should not exceed 30 m.

For detailed description of how to install the reader, please refer to its manual.











| Wire   | Description                          | ACCO-KP2 terminals                                |            |
|--|--------------------------------------|---|------------|
|  |                                      | Terminal A  | Terminal B |
|  red    | power                                | +G1...+G4   |            |
|  green  | data (0)                             | IN1   | IN5        |
|  black  | data (1)<br>[CZ-EMM3 and<br>CZ-EMM4] | do not connect                                    |            |
|  blue   | common ground                        | COM   | COM        |
|  yellow | sounder                              | OUT1  | OUT5       |
|  pink   | green LED                            | OUT2  | OUT6       |
|  gray   | red LED                              | OUT3  | OUT7       |
|  brown  | disabling reader<br>operation        | OUT4  | OUT8       |
|  white  | presence control                     | IN3   | IN7        |
|  violet | OC type output (BELL)<br>[CZ-EMM4]   | IN8...IN12<br>(input programmed as "Bell signal") |            |

Table 5. Method of connecting the CZ-EMM, CZ-EMM2, CZ-EMM3 and CZ-EMM4 readers to the module.



The BELL output is controlled by the bell key. Pressing the key will short the output to common ground.

The black wire is used when the CZ-EMM3 and CZ-EMM4 readers are using the Wiegand interface. It is recommended that the readers use the EM-Marine interface.

### 5.1.5 Connecting the CR-MF3 and SO-MF3 readers



*If the EM-Marine or Wiegand interface is to be used, program the CR-MF3 / SO-MF3 reader in the CR SOFT program before it is connected to the module. For details on how to program and install the readers, please refer to their manuals.*

*The length of cable connecting the reader with the module should not exceed 30 m.*

#### EM-Marine interface

If the CR-MF3 / SO-MF3 reader is to use the EM-Marine interface, connect it to the module as shown in the table below.

| CR-MF3 / SO-MF3 reader terminals | ACCO-KP2 controller terminals |          |
|----------------------------------|-------------------------------|----------|
|                                  | Reader A                      | Reader B |
| TMP                              | IN3                           | IN7      |
| +12V                             | +G1...+G4                     |          |
| COM                              | COM                           |          |
| CLK/D0                           | IN1                           | IN5      |
| IN1                              | OUT3                          | OUT7     |
| IN2                              | OUT2                          | OUT6     |
| IN3                              | OUT1                          | OUT5     |

Table 6. Method of connecting the CR-MF3 and SO-MF3 readers to the module using the EM-Marine interface.

#### Wiegand interface

If the CR-MF3 / SO-MF3 reader is to use the Wiegand interface, connect it to the module as shown in the table below.

| CR-MF3 / SO-MF3 reader terminals | ACCO-KP2 controller terminals |          |
|----------------------------------|-------------------------------|----------|
|                                  | Reader A                      | Reader B |
| DATA/D1                          | IN2                           | IN6      |
| TMP                              | IN3                           | IN7      |
| +12V                             | +G1...+G4                     |          |
| COM                              | COM                           |          |
| CLK/D0                           | IN1                           | IN5      |
| IN1                              | OUT3                          | OUT7     |
| IN2                              | OUT2                          | OUT6     |
| IN3                              | OUT1                          | OUT5     |

Table 7. Method of connecting the CR-MF3 and SO-MF3 readers to the module using the Wiegand interface.

#### RS-485 bus (OSDP)



*The reader can be connected to the RS-485 bus if the module is working in the ACCO NET system.*

*The RS-485 bus may be up to 1200 m long.*

If the CR-MF3 / SO-MF3 reader is to use the OSDP protocol, connect it to the module as shown in the table below.

| CR-MF3 / SO-MF3 reader terminals | ACCO-KP2 terminals |          |
|----------------------------------|--------------------|----------|
|                                  | Reader A           | Reader B |
| RSA                              | A2                 |          |
| RSB                              | B2                 |          |
| +12V                             | +G1...+G4          |          |
| COM                              | COM                |          |

Table 8. Method of connecting the CR-MF3 and SO-MF3 readers to the module using the RS-485 bus (OSDP).

### 5.1.6 Connecting the third-party reader

Connect the Wiegand reader as shown in Table 9.



*The length of cable connecting the reader with the module should not exceed 30 m.*

For detailed description of how to install the reader, please refer to its manual.

| Function                   | ACCO-KP2 terminals |            |
|----------------------------|--------------------|------------|
|                            | Terminal A         | Terminal B |
| power                      | +G1...+G4          |            |
| data (0)                   | IN1                | IN5        |
| data (1)                   | IN2                | IN6        |
| common ground              | COM                | COM        |
| sounder                    | OUT1               | OUT5       |
| green LED                  | OUT2               | OUT6       |
| red LED                    | OUT3               | OUT7       |
| disabling reader operation | OUT4               | OUT8       |
| presence control           | IN3                | IN7        |

Table 9. Method of connecting the Wiegand reader to the module.

### 5.1.7 Connecting the DALLAS iButton reader

Connect the DALLAS iButton reader as shown in Table 10.



*The length of cable connecting the reader with the module should not exceed 30 m.*

For detailed description of how to install the reader, please refer to its manual.







| Wire   | Description     | ACCO-KP2 terminals |            |
|--|-----------------|--------------------|------------|
|  |                 | Terminal A         | Terminal B |
|  brown  | red LED anode   | OUT3               | OUT7       |
|  white  | data            | IN1                | IN5        |
|  gray   | common ground   | COM                | COM        |
|  green  | green LED anode | OUT2               | OUT6       |
|  yellow | LED cathode     | COM                | COM        |

Table 10. Connecting the DALLAS iButton reader to the module.

## 5.2 Connecting activators and door sensors

1. Connect the device which is to activate the door to the relay output. Depending on the device type, use the NO or NC terminal. It is not recommended that the door actuator be powered from the same source as the module.
2. Connect the sensor monitoring the door status to one of the module inputs.

 *By default, the input IN8 is programmed as the “Door status control”, NO type. However, you can select any of the programmable inputs and configure it accordingly.*

## 5.3 Mantrap / airlock

The mantrap / airlock consists of at least 2 doors. It requires the use of 1 module for each door (see Fig. 13). Only 1 door at a time can be opened in the mantrap / airlock.

Explanations for Fig. 13:

- ① module 1 supervising the door 1.
- ② door 1 activator (electromagnetic lock controlled from the relay output of module 1).
- ③ door 1 status sensor (magnetic contact connected to the module 1 input programmed as “Door status control” and the module 2 input programmed as “Interlocking door control”).
- ④ entry terminal (proximity card reader connected to module 1 as terminal A).
- ⑤ button unlocking the door 1 (connected to the module 1 input programmed as “Unlock button” – substitutes the exit terminal for the door 1).
- ⑥ module 2 supervising the door 2.
- ⑦ door 2 activator (electromagnetic lock controlled from the relay output of module 2).
- ⑧ door 2 status sensor (magnetic contact connected to the module 2 input programmed as “Door status control” and the module 1 input programmed as “Interlocking door control”).
- ⑨ button unlocking the door 2 (connected to the module 2 input programmed as “Unlock button” – substitutes the exit terminal for the door 2).
- ⑩ exit terminal (proximity card reader connected to module 2 as terminal B).

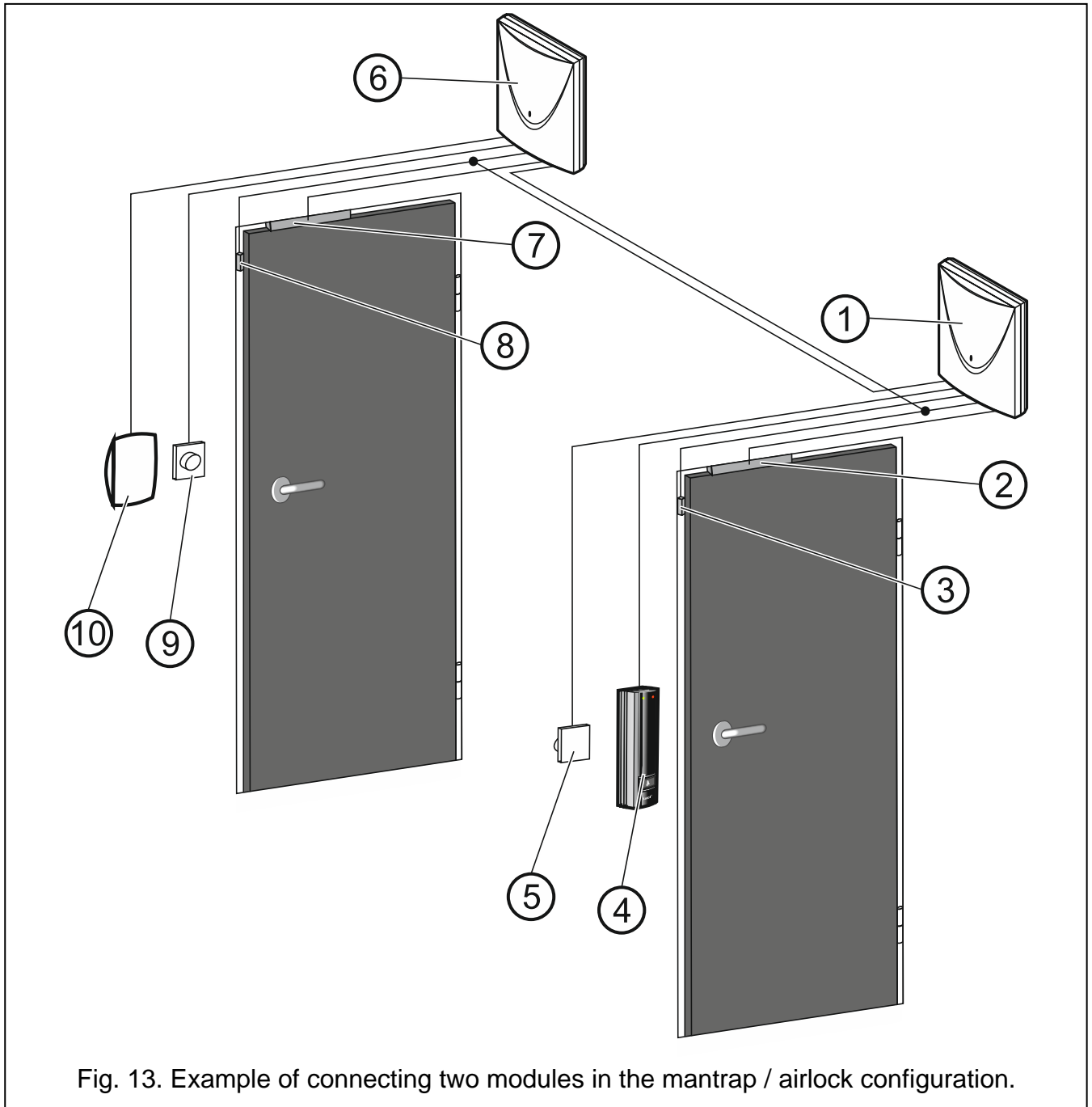

*In the case of mantrap / airlock consisting of 3 or more doors, remember to connect the magnetic contacts correctly. Each contact connected to an input programmed as "Door status control" of one of the modules, must be also connected to inputs programmed as "Interlocking door control" of all other modules creating a mantrap / airlock.*

#### 5.4 Connecting the power supply and starting the module



**Do not connect power supply until the installation work is completed.**

The ACCO-KP2 module requires power supply of 12 VDC ( $\pm 15\%$ ). SATEL offers power supplies (e.g. APS-412), which can be connected to the APS connector on the electronics board.

1. Depending on the selected method of module powering, connect the power supply unit to the APS connector or connect the power leads to the +12V and COM terminals.

**⚠ | Never connect power supply to APS connector and terminals at the same time.**

2. Power up the module. The module will start up.

## 6. Module in the access control system

### 6.1 Access control system without control panel (ACCO)

You can connect the ACCO-KP2 modules using the RS-485 bus in order to build the ACCO access control system. The system may comprise up to 255 modules. The data necessary for access control is stored in the memory of each module, which allows the modules to work as stand-alone devices. Each module decides on its own whether to grant access or deny it. The RS-485 bus makes it possible to synchronize time and existing user data across the modules.

Use the ACCO-USB converter to connect to the RS-485 bus a computer with the ACCO-SOFT-LT program installed and configure the modules in the system (the converter is not required for the system to operate but you will need it for system configuration). For detailed description of the converter, please refer to its manual.

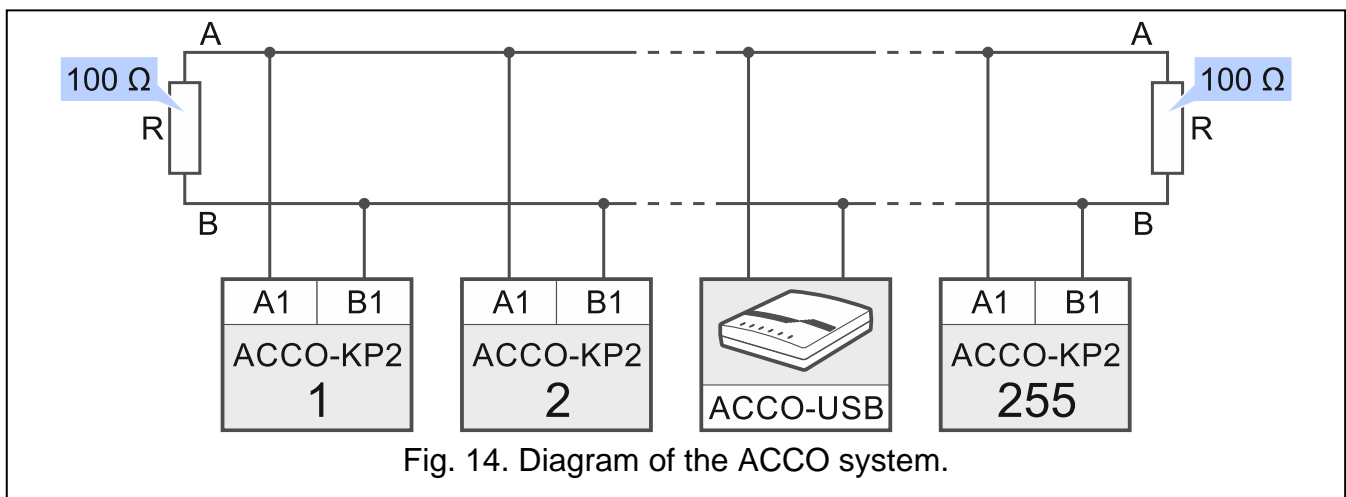

Fig. 14. Diagram of the ACCO system.

### 6.2 Access control system with the ACCO-NT control panel (ACCO NET)

You can connect the ACCO-KP2 modules to the ACCO-NT control panel using the RS-485 bus in order to build the ACCO NET access control system. The ACCO NET system may include any number of access control panels. Up to 255 ACCO-KP2 modules may be connected to one ACCO-NT control panel. The access control panels decide whether the user will be granted access or not. In order for all components of the system to work properly, the devices and the ACCO-NT control panels must communicate with the ACCO Server program. The ACCO Server program is used as an intermediate for communication between the access control panels on one end, and the database, the ACCO Soft and ACCO-WEB programs and the ACCO-EE component on the other. The database stores the system settings and the event log. For more information about the ACCO NET system, please refer to the manuals of the system itself and its components.

## 7. Specifications

---

### 7.1 ACCO-KP2 module

---

|                                     |                        |
|-------------------------------------|------------------------|
| Supply voltage .....                | 12 VDC $\pm$ 15%       |
| Standby current consumption .....   | 110 mA                 |
| Maximum current consumption .....   | 480 mA                 |
| Relay output (resistive load) ..... | 8 A / 250 VAC / 30 VDC |
| Outputs OUT1...OUT12 .....          | 50 mA / 12 VDC         |
| Outputs +G1...+G4 .....             | 0.5 A / 12 VDC         |
| Maximum humidity .....              | 93 $\pm$ 3%            |
| Dimensions .....                    | 142 x 71 mm            |
| Weight.....                         | 110 g                  |

### 7.2 ACCO-KLCDR keypad

---

|                                   |  |
|-----------------------------------|--|
| Supply voltage .....              | 12 VDC $\pm$ 15%                       |
| Standby current consumption ..... | 60 mA                                  |
| Maximum current consumption ..... | 160 mA                                 |
| Reader transmit frequency.....    | 125 kHz                                |
| Supported card standards.....     | UNIQUE, EM4001, EM4002, EM4003, EM4102 |
| Maximum humidity .....            | 93 $\pm$ 3%                            |
| Dimensions .....                  | 140 x 126 x 26 mm                      |
| Weight.....                       | 236 g                                  |

### 7.3 ACCO-SCR keypad with proximity card reader

---

|                                   |  |
|-----------------------------------|--|
| Supply voltage .....              | 12 VDC $\pm$ 15%                       |
| Standby current consumption ..... | 85 mA                                  |
| Maximum current consumption ..... | 110 mA                                 |
| Reader transmit frequency.....    | 125 kHz                                |
| Supported card standards.....     | UNIQUE, EM4001, EM4002, EM4003, EM4102 |
| BELL output, OC type .....        | 30 mA / 12 VDC                         |
| Maximum humidity .....            | 93 $\pm$ 3%                            |
| Dimensions .....                  | 47 x 158 x 24 mm                       |
| Cable length.....                 | 3.80 m                                 |
| Weight.....                       | 237 g                                  |