

Roger Access Control System MCX402-BRD Installation Manual

Firmware version: 1.1.0.302 and newer

Hardware version: 1.4

Document version: Rev. D



This document contains minimum information that is necessary for initial setup and installation of the device. The detailed description of configuration parameters and functionalities is specified in respective Operating Manual available at www.roger.pl.

INTRODUCTION

The expander is designed to operate in RACS 5 system as peripheral device connected to RS485 bus of MC16 access controller. Depending on uploaded firmware the expander enables to control single door by MC16 controller using two terminals with Wiegand interface or two PRT series terminals. MCX402-BRD is installed in MCX402-1-KIT.

Factory new device is configured with default settings including ID=100 address. Before connecting to MC16 controller, the device should be assigned with unoccupied address in range of 100-115. Programming of other parameters depends on the individual requirements and is not obligatory. Configuration of the expander with RogerVDM requires RUD-1 interface.

CONFIGURATION WITH ROGERVDM PROGRAM

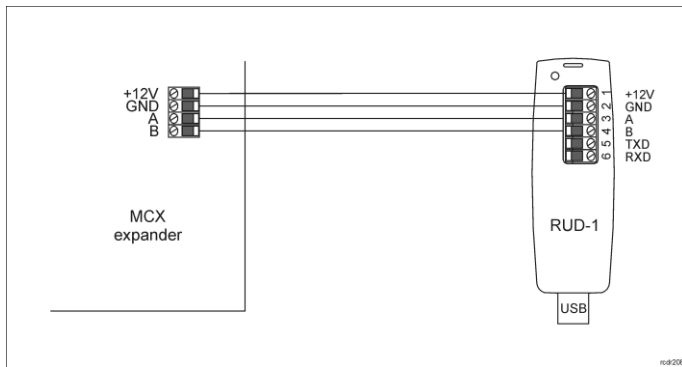

Fig. 1 Connection of the expander to RUD-1 interface

Programming procedure with RogerVDM software:

1. Connect the device to RUD-1 interface (fig. 1) and connect the RUD-1 to computer's USB port.
2. Start RogerVDM program, select *MCX v1.x* device, firmware version, *RS485* communication channel and serial port with RUD-1 interface.
3. Click *Connect*, the program will establish connection and will automatically display *Configuration* tab.
4. Enter unoccupied RS485 address in range of 100-115, enable Wiegand or PRT terminals, configure input types (e.g. NC for IN5 according to fig. 5) and other settings according to requirements of specific installation.
5. Click *Send to Device* to update the configuration of device.
6. Optionally make a backup by clicking *Send to File...* and saving settings to file on disk.

Note: Time to connect to the device in RogerVDM is 30 seconds from power up. In case of timeout, a power reset should be performed just before the connection.

MANUAL ADDRESSING

The RS485 address of expander configured with RogerVDM is a software address. Alternatively hardware RS485 address can be configured with jumpers and such address has higher priority than software address.

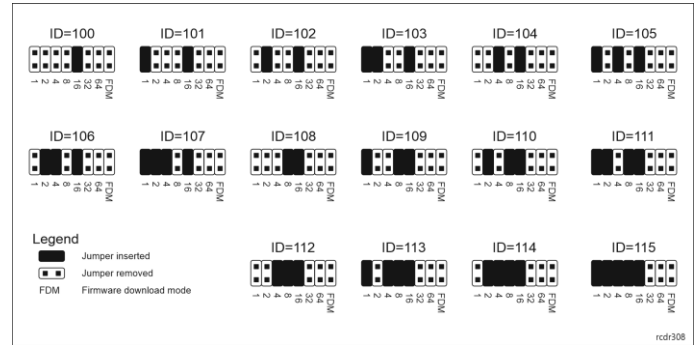

Fig. 2 Manual addressing of expander

Note: Each time the hardware RS485 address is modified the device must be restarted

MEMORY RESET

Memory reset procedure restores factory default settings including ID=100 software address.

Expander memory reset procedure:

1. Remove all connections from A, B, CLK and DTA terminals.
2. Place jumper on 64 contacts and restart device with RST button on device board or by switching supply off and on.
3. Remove jumper from 64 contacts when LED STAT (red), LED OPN and LED SYS are ON.
4. LED OPN and LED SYS will switch off and device shall restart automatically with factory default settings.

FIRMWARE UPDATE

Factory new expander is equipped with a firmware dedicated to Wiegand readers. If the expander is to be operated with PRT readers then another firmware must be uploaded. Such firmware is available at www.roger.pl. Firmware update requires RogerISP program.

Expander firmware update procedure:

1. Connect the device to RUD-1 interface (fig. 1) and connect the RUD-1 to computer's USB port.
2. Place jumper on FDM contacts
3. Restart device with RST button on device board or by switching supply off and on.
4. Start RogerISP software.
5. Select serial port emulated by RUD-1 interface and the option *USB-RS485 Converter*.
6. Select firmware file (*.hex), click *Program* and follow instructions on screen.
7. Once the firmware is uploaded remove the FDM jumper and restart the device.
8. Start Memory reset procedure.

APPENDIX

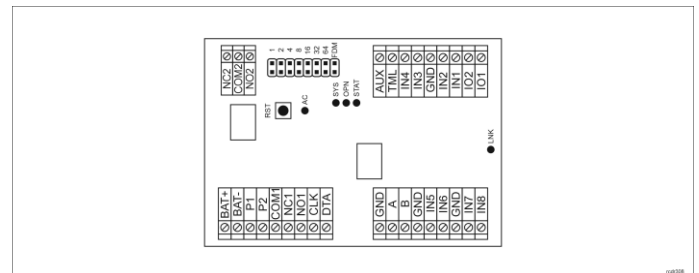

Fig. 3 MCX402-BRD expander

Table 1. Screw terminals	
Name	Description
BAT+, BAT-	Backup battery

P1	24VDC input power supply
P2	Ground
AUX	12VDC/1.0 output power supply (for door lock)
TML	12VDC/0.2A output power supply (for readers)
IN1-IN8	Input lines
GND	Ground
IO1, IO2	15VDC/1A transistor output lines
A, B	RS485 bus
CLK, DTA	RACS CLK/DTA bus
NO1, COM1, NC1	30V/1.5A AC/DC (REL1) relay
NO2, COM2, NC2	30V/5A AC/DC (REL2) relay

Table 2 . LED indicators

Indicator	Colour	Integral function
AC	Red	AC power supply
STA	Red/ green	Current arming mode of Alarm Zone (armed/disarmed)
OPN	Green	Door unlocked
SYS	Orange	Various signalling functions including errors
LINK	Green	Data transmission on RS485 bus

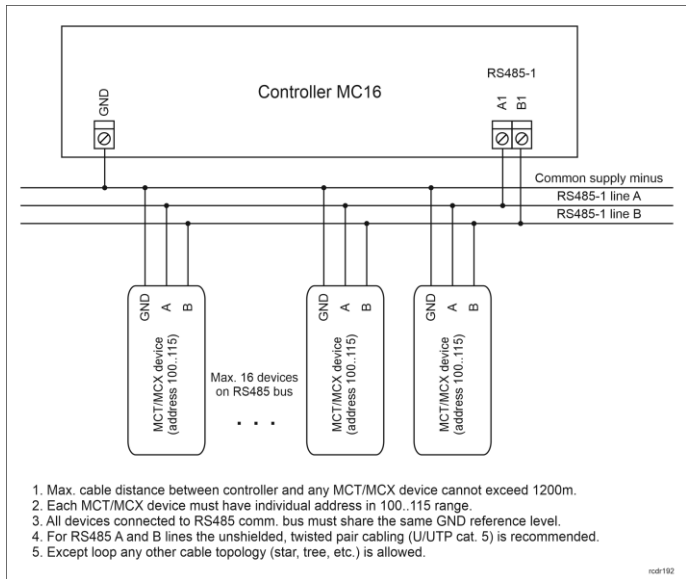

Fig. 5 Connection of readers and expanders to MC16 access controller

Table 3. Specification

Supply voltage	Nominal 18VAC, min./max. range 17-22VAC Nominal 12VDC, min./max. range 10-15VDC Nominal 24VDC, min./max. range 22-26VDC
Current consumption (average)	100 mA (excluding load points connected to AUX and/or TML outputs)
Battery charging current	300mA
Inputs	Eight (IN1..IN8) NO/NC inputs, triggering level app. 3.5V
Relay outputs	Two (REL1,REL2) relay outputs with isolated NO/NC contacts, 1.5A/30VACDC (REL1) and 5A/30VACDC (REL2) max. loads
Transistor outputs	Two (IO1, IO2) transistor outputs, max load 15VDC/1A
Power supply outputs	Two power outputs (AUX, TML), 12VDC/0.2A (TML) and 12VDC/1A (AUX) max loads
Distances	Up to 1200 m between controller and expander (RS485) Up to 150m between expander and Wiegand or PRT terminals
IP Code	IP20
Environmental class (according to EN 50133-1)	Class I, indoor general conditions, temperature: +5°C to +40°C, relative humidity: 10 to 95% (no condensation)
Dimensions W x S x G	80 x 115 x 28mm
Weight	100g
Compliance	CE, RoHS

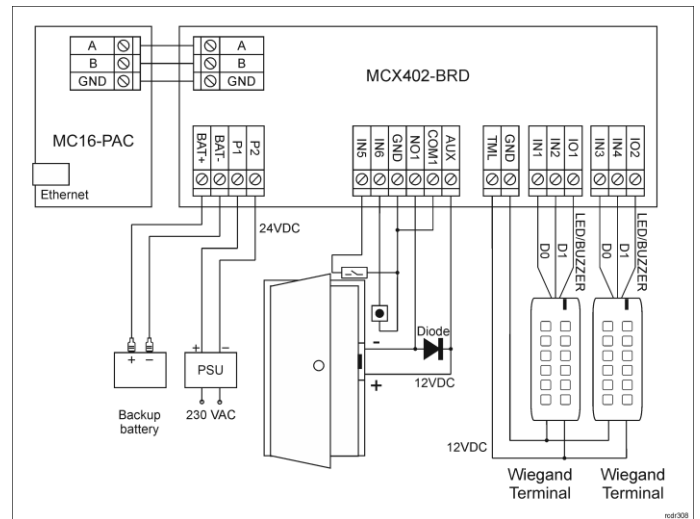

Fig. 5 Typical door control with Wiegand readers

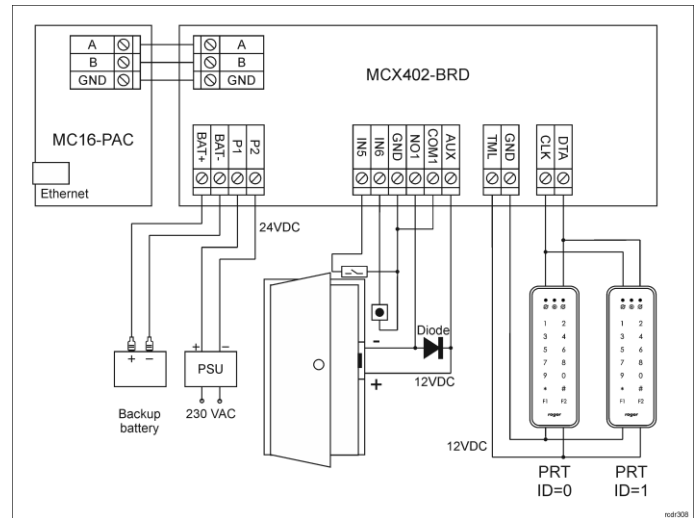

Fig. 6 Typical door control with PRT readers

- By default the expander is uploaded with firmware for Wiegand readers. In case of operation with PRT readers it is necessary to upload new firmware from www.roger.pl.
- In case of read-in door, single reader is connected to the expander.
- Any 24VDC/1.5A PSU or 18VAC/40VA transformer can be used for expander and door devices. In case of 12VDC PSU the backup battery cannot be connected to the expander.
- Any unoccupied IN1-IN8 inputs of the expander can be used for connection of door contact and exit button.
- Diagrams include doors with electric strikes. In case of electromagnetic lock, the NC terminal of relay is used instead of NO terminal.
- Diagrams includes exit buttons. In case of read-in/out doors they can be used for emergency door opening.



This symbol placed on a product or packaging indicates that the product should not be disposed of with other wastes as this may have a negative impact on the environment and health. The user is obliged to deliver equipment to the designated collection points of electric and electronic waste. For detailed information on recycling, contact your local authorities, waste disposal company or point of purchase. Separate collection and recycling of this type of waste contributes to the protection of the natural resources and is safe to health and the environment. Weight of the equipment is specified in the document.

Contact:
Roger Sp. z o. o. sp. k.
 82-400 Sztum
 Gościszewo 59
 Tel.: +48 55 272 0132
 Fax: +48 55 272 0133
 Tech. support: +48 55 267 0126
 E-mail: support@roger.pl
 Web: www.roger.pl