

Roger Access Control System

MCT88M-IO Installation Manual

Firmware version: 1.0.6.193 and newer,
2.0.8.197 and newer

Document version: Rev.N



This document contains minimum information that is necessary for initial setup and installation of the device. The detailed description of configuration parameters and functionalities is specified in respective Operating manual available at www.roger.pl.

INTRODUCTION

The terminal is designed for operation with MC16 access controller (RACS 5 system). Alternatively, the device can communicate with virtual controller via Ethernet (LAN) and operate as PoS terminal or assets tracking terminal. Factory new terminal is configured with default settings including ID=100 address.

DEVICE CONFIGURATION

The terminal can be configured in regard of various parameters (including address) in order to adapt it to the requirements of specific installation. Device can be configured from VISO v2 management software or RogerVDM utility software.

Note: Remote configuration of device from VISO v2 software is possible only if jumper is placed on MEM contacts (fig. 3). If the jumper is removed, then such configuration is blocked. In case of factory new device, jumper is placed on MEM contacts.

CONFIGURATION WITH VISO V2 PROGRAM

In RACS 5 v2 system, when connected to MC16 controller, the terminal can be installed at site without previous configuration. According to AN006 application note, its address and other settings can be configured from VISO v2 management software and during such configuration the access to its service contacts (fig. 3) is not required.

CONFIGURATION WITH ROGERVDM PROGRAM

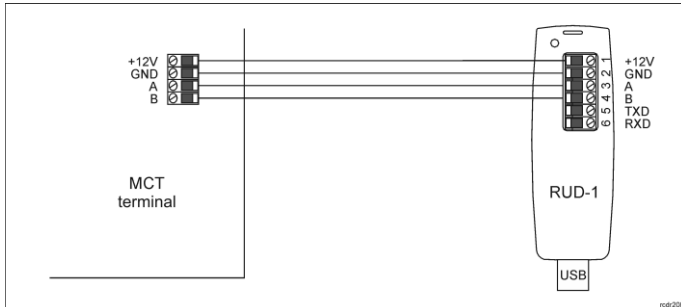

Fig. 1 Connection of MCT reader to RUD-1 interface.

Programming procedure:

1. Connect the device to RUD-1 interface (fig. 1) and connect the RUD-1 to computer's USB port.
2. Remove jumper from MEM contacts (fig. 3) if it is placed there.
3. Restart the device (switch power supply off and on) and orange LED SYSTEM will pulsate. Then within 5 seconds place jumper on MEM contacts and the terminal will display CONFIG MODE text.
4. Start RogerVDM program, select *MCT* device, v2.0, adequate firmware version, *RS485* communication channel and serial port with RUD-1 interface.
5. Click *Connect*, the program will establish connection and will automatically display *Configuration* tab.
6. Select *RS485* communication interface and specify unoccupied RS485 address in range of 100-115 or select *Ethernet* communication interface and specify IP address. Configure other low level configuration parameters as needed.
7. Click *Send to Device* to update the configuration of device.
8. Optionally make a backup by clicking *Send to File...* and saving settings to file on disk.
9. Remove jumper from MEM contacts and disconnect device from RUD-1 interface.

Note: If the USB port does not offer enough power output, then supply the terminal from external PSU with min. 12VDC/200mA power output.

Note: Do not read any cards nor press keypad when device is configured with RogerVDM.

MANUAL ADDRESSING

Manual addressing procedure enables configuration of new RS485 address with all other settings unchanged.

Manual addressing procedure:

1. Remove all connections from A and B lines.
2. Remove jumper from MEM contacts (fig. 3) if it is placed there.
3. Restart the device (switch power supply off and on) and orange LED SYSTEM will pulsate. Then within 5 seconds place jumper on MEM contacts and the terminal will display CONFIG MODE text.
4. Enter 3 digits of RS485 address in range of 100-115 with keypad.
5. Wait till device starts to emit continuous sound.
6. Leave jumper on MEM contacts to enable further configuration of device from VISO v2 software or remove jumper from MEM contacts to block such remote configuration.
7. Restart the device.

MEMORY RESET

Memory reset procedure resets all settings to factory default ones including ID=100 address.

Memory reset procedure:

1. Remove all connections from A and B lines.
2. Remove jumper from MEM contacts (fig. 3) if it is placed there.
3. Restart the device (switch power supply off and on) and orange LED SYSTEM will pulsate. Then within 5 seconds place jumper on MEM contacts and the terminal will display CONFIG MODE text.
4. Press [*] or read any MIFARE card 11 times.
5. Wait till device confirms reset with continuous sound.
6. Leave jumper on MEM contacts to enable further configuration of device from VISO v2 software or remove jumper from MEM contacts to block such remote configuration.
7. Restart the device.

FIRMWARE UPDATE

The firmware of device can be changed to newer or older version. Main firmware can be uploaded to the terminal by means of included memory card. The keyboard firmware update requires connection to computer with RUD-1 interface (fig. 1) and starting RogerVDM software. The latest firmware file is available at www.roger.pl.

Note: During the firmware update process, it is necessary to ensure continuous and stable power supply for the device. If interrupted the device may require repair by Roger.

Note: Backup configuration with RogerVDM software before firmware update because the update will restore factory default settings.

Main firmware update procedure:

1. Disconnect power supply.
2. Press and remove memory card from socket (fig. 3).
3. Using memory card reader, copy main firmware (*.frg) to the card and rename it as FW.BUF.
4. Insert the card into socket.
5. Connect power supply. During firmware update the LED STATUS (red) will pulsate and the LED OPEN (green) will be switched on and after firmware update the LED SYSTEM (orange) will pulsate.
6. Restart the device (switch power supply off and on) and orange LED SYSTEM will pulsate. Then within 5 seconds place jumper on MEM contacts and the terminal will display CONFIG MODE text.
7. Start RogerVDM program and perform low level configuration or restore the configuration from backup file using *Read from File...* command.

Keyboard firmware update procedure:

1. Connect the device to RUD-1 interface (fig. 1) and connect the RUD-1 to computer's USB port.
2. Place jumper on MEM contacts (fig. 3).
3. Restart the device (switch power supply off and on).
4. Start RogerVDM program and in the top menu select *Tools* and then *Update firmware*.
5. In the opened window select device type, serial port with RUD-1 interface and path to keyboard firmware (*.cyacd).
6. Click *Update* to start firmware upload with progress bar in the bottom.
7. When the update is finished, disconnect from RUD-1 interface and remove jumper from MEM contacts. Additionally, it is recommended to start memory reset procedure.

APPENDIX

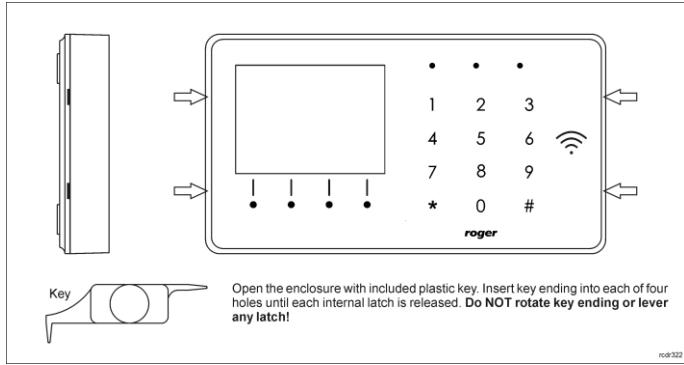

Fig. 2 Enclosure disassembly

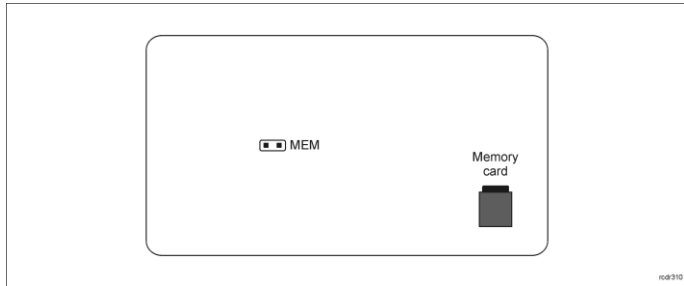

Fig. 3 Service contact and memory card

Table 1. Screw terminals	
Screw terminal	Description
+12V	12VDC power supply
GND	Ground
A	RS485 bus, line A
B	RS485 bus, line B
COM	REL relay common terminal
NC	REL relay output (NC)
NO	REL relay output (NO)
IN1	IN1 input line
IN2	IN2 input line
IN3	IN3 input line
OUT1	OUT1 output line
OUT2	OUT2 output line
1,2,3,4,5,6,7,8	Ethernet port

Table 2. Specification	
Supply voltage	Nominal 12VDC, min./max. range 10-15VDC
Current consumption (average)	~110 mA
Inputs	Three parametric inputs internally connected to the power supply plus (+12V) through a 5.6kΩ resistor, approx. 3.5V triggering level when configured as NO or NC.
Relay output	MCT88M-IO v1: Relay output with single NO/NC contacts, rated 30V/1,5A MCT88M-IO v2: Relay output with single NO/NC contacts, rated 30V/1A
Transistor outputs	Two (IO1, IO2) open collector outputs, 15VDC/150mA rated
Tamper protection	Enclosure opening reported to access controller
Identification methods	ISO/IEC14443A MIFARE Ultralight, Classic, Desfire (EV1, EV2, EV3) and Plus proximity cards Mobile device (Android) compatible with NFC Mobile device (Android, iOS) compatible with BLE (Bluetooth Low Energy) v4.1
Reading range	Up to 7 cm for MIFARE and NFC Up to 10 m for BLE – depends on ambient conditions and particular mobile device. Terminal's radio power can be increased within low level configuration.
Distances	Up to 1200 m between controller and terminal (RS485)
IP Code	IP30
Environmental class (acc. to EN 50133-1)	Class I, indoor general conditions, temperature: +5°C to +40°C, relative humidity: 10 to 95% (no condensation)
Dimensions H x W x D	85 x 155,5 x 21,5 mm
Weight	190g
Certificates	CE, RoHS

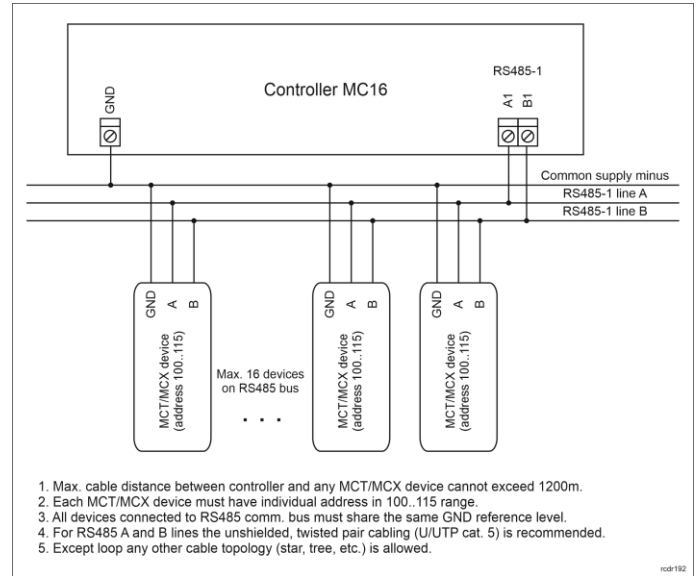

Fig. 5 Connection of terminals and expanders to MC16 access controller

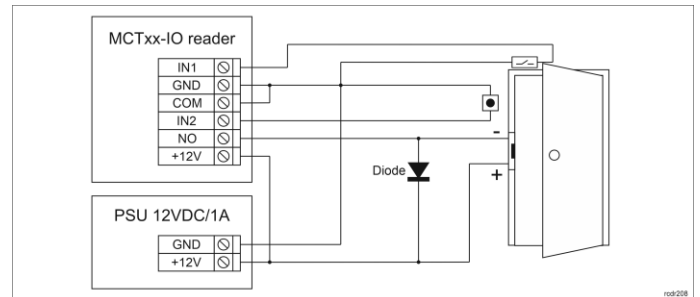
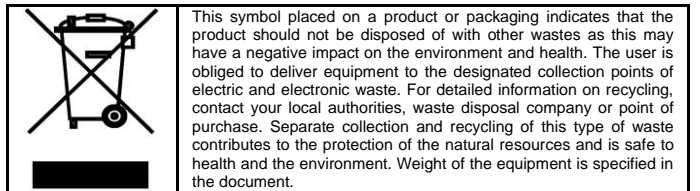

Fig. 6 Connection of door lock, door contact and exit button to MCTxx-IO terminal.

INSTALLATION GUIDELINES

- The terminal should be mounted on a vertical structure (wall) away from sources of heat and moisture.
- In particular, it is not allowed to install the reader in places with high humidity such as saunas, swimming pools, car washes, etc.
- Front panel should be attached in such way as the tamper detector would firmly press the back panel.
- All electrical connections should be done with disconnected power supply.
- If the terminal and controller are not supplied from the same PSU, then GND terminals of both devices must be connected with any wire.
- Device can be cleaned by means of wet cloth and mild detergent without abrasive components. In particular do not clean with alcohols, solvents, petrol, disinfectants, acids, rust removers, etc. Damages resulting from improper maintenance and usage are not covered by manufacturer warranty.
- If the reader is installed in EU countries, the BLE radio power level (parameters: *BLE broadcasting power [dBm]* and *BLE transmission power [dBm]*) should be set to 1(-18dBm).



Contact:
Roger Sp. z o. o. sp. k.
 82-400 Sztum
 Gościszewo 59
 Tel.: +48 55 272 0132
 Fax: +48 55 272 0133
 Tech. support: +48 55 267 0126
 E-mail: support@roger.pl
 Web: www.roger.pl