

Roger Access Control System

MCT68ME-IO Installation Manual

Firmware version: 2.1.0.307 and newer

Document version: Rev.F



This document contains minimum information that is necessary for initial setup and installation of the device. The detailed description of configuration parameters and functionalities is specified in respective Operating manual available at www.roger.pl.

INTRODUCTION

The reader is designed for operation with MC16 access controller (RACS 5 system). Factory new reader is configured with default settings including ID=100 address. MCT68ME reader is available in indoor and outdoor versions. The latter one is equipped with additional, protecting metal enclosure.

DEVICE CONFIGURATION

The reader can be configured in regard of various parameters (including address) in order to adapt it to the requirements of specific installation. Device can be configured from VISO v2 management software or RogerVDM utility software.

CONFIGURATION WITH VISO V2 PROGRAM

In RACS 5 v2 system the reader can be installed at site without previous configuration. According to AN006 application note, its address and other settings can be configured from VISO v2 management software and during such configuration the access to its service contacts (fig. 2) is not required.

CONFIGURATION WITH ROGERVDM PROGRAM

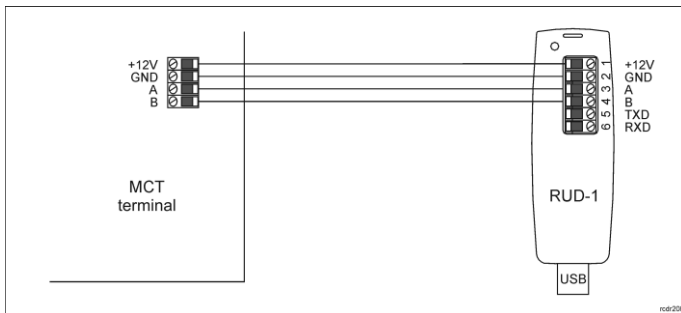

Fig. 1 Connection of MCT terminal to RUD-1 interface

Programming procedure:

1. Connect the device to RUD-1 interface (fig. 1) and connect the RUD-1 to computer's USB port.
2. Start RogerVDM program, select *MCT* device, firmware version, *RS485* communication channel and serial port with RUD-1 interface.
3. Click *Connect*, the program will establish connection and will automatically display *Configuration* tab.
4. Enter unoccupied RS485 address in range of 100-115 and other settings according to requirements of specific installation.
5. Click *Send to Device* to update the configuration of device.
6. Optionally make a backup by clicking *Send to File...* and saving settings to file on disk.
7. In the top menu select *Device->Disconnect*.
8. Disconnect device from RUD-1 interface.

Note: Do not read any cards nor press reader keypad when reader is configured with RogerVDM.

MEMORY RESET

Memory reset procedure enables configuration of RS485 address and resets all other settings to factory default ones.

Memory reset procedure:

1. Remove all connections from A and B lines.
2. Place jumper on MEM contacts (fig. 2)
3. Restart the device (switch power supply off and on or short RST contacts for a moment).
4. When 'CONFIG RESET' is displayed by reader then remove jumper from MEM contacts.
5. When 'ID:' is displayed by reader then enter 3 digits of RS485 address in range of 100-115 with reader keypad.
6. When the third digit is defined then the reader will restart with the new address.

FIRMWARE UPDATE

The update requires connection of reader to computer with RUD-1 interface (fig. 1) and starting RogerISP software. The latest firmware file is available at www.roger.pl.

Firmware update procedure:

1. Connect the reader to RUD-1 interface (fig. 1) and connect the RUD-1 to computer's USB port.
2. Place jumper on FDM contacts (fig. 2).
3. Restart the reader (switch power supply off and on or short RST contacts for a moment).
4. Start RogerISP program.
5. Select serial port with RUD-1 interface and *USB-RS485 Converter* option.
6. Specify path to firmware file (*.hex).
7. Click *Program* and proceed according to displayed messages.
8. Remove jumper from FDM contacts and restart the reader.

APPENDIX

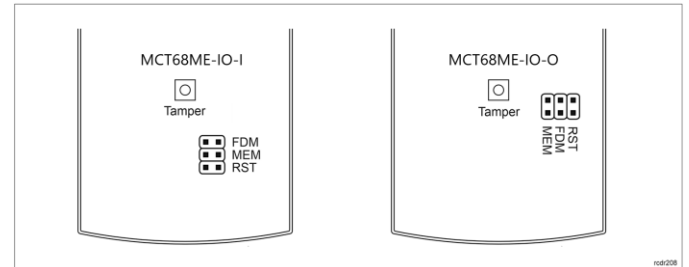

Fig. 2 Service contacts

Table 1. Terminals

Screw terminal	Description	Wire color
12V	Supply plus	Red
GND	Ground	Black
IN1	IN1 input line	Pink
IN2	IN2input line	Blue
IN3	IN3 input line	White/Yellow
RS485 A	RS485 bus, line A	Brown
RS485 B	RS485 bus, line B	White/Green
CLK	Not used	White
DTA	Input/output line	Green
TMP	Tamper contact	Yellow
TMP	Tamper contact	Gray
IO1	IO1 output line	Yellow/Brown
IO2	IO2 output line	Brown/Green
REL1-NC	REL1 relay output (NC)	Gray/Pink
REL1-COM	REL1 relay common terminal	Red/Blue
REL1-NO	REL1 relay output (NO)	Purple

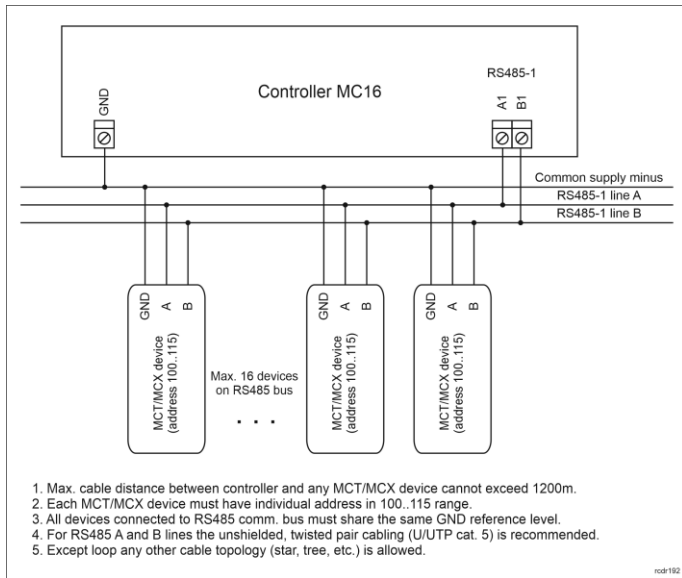

Fig. 3 Connection of readers and expanders to MC16 access controller

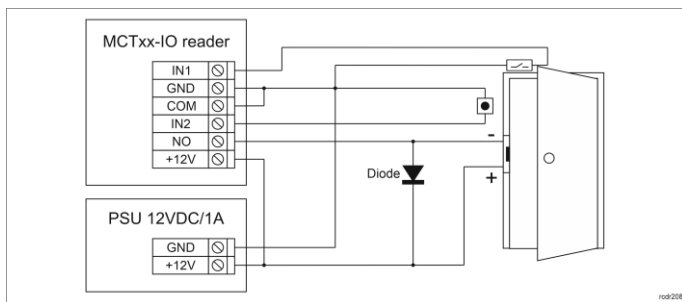

Fig. 4 Connection of door lock, door contact and exit button to MCTxx-IO terminal

Table 2. Specification	
Supply voltage	Nominal 12VDC, min./max. range 10-15VDC
Current consumption (average)	~100 mA
Inputs	Three NO/NC inputs (IN1..IN3) internally connected to the power supply plus through a 15kΩ resistor, approx. 3.5V triggering level
Relay output	Relay output (REL1) with single NO/NC contact, 30V/1.5A DC/AC max. load
Transistor outputs	Two (IO1, IO2) open collector outputs, 15VDC/150mA max. load
DTA input/output	I/O line configured as NO/NC input or open collector output with 15VDC/15mA max. load
Tamper protection	Isolated 24V/50mA contacts, shorted when enclosure is closed
Proximity cards	EM 125 kHz UNIQUE according to EM4100/4102 and 13.56MHz according to ISO14443A and MIFARE
Reading range	Up to 10 cm for EM125kHz Up to 7 cm for MIFARE
Distance	1200m maximal cable length for RS485 bus between controller and reader
IP Code	MCT68ME-IO-I: IP30 MCT68ME-IO-O: IP54
Environmental class (according to EN 50133-1)	MCT68ME-IO-I: Class II, indoor general conditions, temperature: -10°C to +50°C, relative humidity: 10 to 95% (no condensation) MCT68ME-IO-O: Class IV, outdoor general conditions, temperature: -25°C to +60°C, relative humidity: 10 to 95% (no condensation)
Dimensions H x W x D	MCT68ME-IO-I: 170 x 110 x 42 mm MCT68ME-IO-O: 220 x 156 x 104 mm
Weight	MCT68ME-IO-I: ~410g MCT68ME-IO-O: ~1150g
Certificates	CE

INSTALLATION GUIDELINES

- The terminal should be mounted on a vertical structure (wall) away from sources of heat and moisture.
- In particular, it is not allowed to install the reader in places with high humidity such as saunas, swimming pools, car washes, etc.
- Front panel should be attached in such way as the tamper detector would firmly press the back panel.

- All electrical connections should be done with disconnected power supply.
- If the terminal and controller are not supplied from the same PSU, then GND terminals of both devices must be connected with any wire.
- Device can be cleaned by means of wet cloth and mild detergent without abrasive components. In particular do not clean with alcohols, solvents, petrol, disinfectants, acids, rust removers, etc. Damages resulting from improper maintenance and usage are not covered by manufacturer warranty.

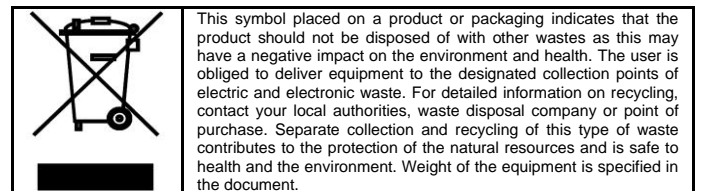

This symbol placed on a product or packaging indicates that the product should not be disposed of with other wastes as this may have a negative impact on the environment and health. The user is obliged to deliver equipment to the designated collection points of electric and electronic waste. For detailed information on recycling, contact your local authorities, waste disposal company or point of purchase. Separate collection and recycling of this type of waste contributes to the protection of the natural resources and is safe to health and the environment. Weight of the equipment is specified in the document.

Contact:
 Roger Sp. z o. o. sp. k.
 82-400 Sztum
 Gościszewo 59
 Tel.: +48 55 272 0132
 Fax: +48 55 272 0133
 Tech. support: +48 55 267 0126
 E-mail: support@roger.pl
 Web: www.roger.pl